

# Enjoy the Outdoors™

*Where ever you find it ...*

*Camping*

*Schools & Colleges*

*Athletic Fields*

*Parks*

*Swimming Pools*

*Rec Centers*

*Streetscapes*

*Patios*

*Your Backyard*

**Pilot**  
**Rock®**

PARK · STREET · CAMP  
SITE PRODUCTS

RJThomas Mfg. Co, Inc.



## Park & Street Benches ..... 5-25

Square Frame Benches — B130 Series .....	5
<i>New!</i> Sign Benches B400 & B410 Series .....	6-7
Channel Bench — CXB Series .....	8-9
Contemporary Bench — B120 Series .....	10
Accessible Bench — B110 & B111 Series .....	11
Armrests .....	11
Contour Benches — WRB & OWRB Series .....	12
Wall Mount Bench — WMB Series .....	13
Trailside Bench — WB & OWB Series .....	13
Amherst Bench — B100 & B102 Series .....	14
Park Avenue Bench — BC3001 & BC4001 Series .....	14
Gibraltar Bench — GB Series .....	15
Classic Bench — CLB Series .....	15
Grey Creek Bench — B30 Series .....	16
Silver Sioux Bench — B40 Series .....	17
Riverview Bench — B60 & B70 Series .....	18-19
Gillette Bench — B80 Series .....	20
Oak Knoll Bench — B90 Series .....	21
Locker Room & Athletic Benches .....	22-23
Recycled Plastic Benches — RBF & RBB Series .....	24
Product Signage .....	25

## Park Tables ..... 26-47

Universal Access Table — WUT, WXT, WPTS Series .....	26-27
Heavy Duty — UT Series .....	28
Extra Heavy Duty — XT Series .....	29
Accessible Tables .....	30
Accessibility Compliance Comparison .....	31
Snow Load/Extreme Load Table Ratings .....	32
Kid's Table — UTK, SQTk, T104K Series .....	33
A-Frame Table — AT, WAT, AFT Series .....	34-35
Caterpillar Table — T600 Series .....	36
Light Duty — BT Series .....	36
Recycled Plastic Table — RT, ART Series .....	37
Square Tables — Portable — SQT Series .....	38
Square Tables — Pedestal — PQT Series .....	39
Round Tables — T100, T200, T300, T400 Series .....	40-41
Multi-Pedestal Table — APT Series .....	42
Twin Pedestal Table — TPT Series .....	43
Single Pedestal Table — PT Series .....	43
Square Frame Picnic Tables & Utility Tables .....	44
Umbrellas .....	45
Accessories for Tables .....	46
Table Mover — TM-500 .....	47

## Material & Color Options ..... 47-50

## Waste & Recycling ..... 51-72

Tilting Trash Receptacle — CN-TR-52 Series .....	51
Round Steel Strap Receptacle — CN-R/SS2 Series .....	52
Round Cut Steel Plate Receptacle — CN-R/SP2 Series .....	52
Round Perforated Steel Receptacle CN-R/R Series .....	52
Round Expanded Steel Receptacle — CN-R/D Series .....	53
Square Expanded Steel Receptacle CN-Q/D-32 Series .....	53
Park Policeman — CN-EXP Series .....	53
Trash & Recycling Receptacles — TRH & TRQ Series .....	54-55
Ash Receptacles — TRH, TRQ, AMR, & AMQ Series .....	55-56
Amherst Receptacles — AMR & AMQ Series .....	56
Oak Knoll Receptacle — OKR Series .....	57
<i>New!</i> Steel Strap Receptacle with Door — CN-R/SS2-36D .....	57
<i>New!</i> Square Receptacle with Door — CN-Q/SS4-36D .....	58
<i>New!</i> Square Frame Receptacle — CN-Q-36 .....	58
Vertical Wave Steel Strap Receptacle — CN-R/SS3 Series .....	59
Vertical Wave Steel Strap Ash Receptacle .....	59
Smoker's Stack .....	59
Trash & Recycling Receptacle Lids .....	60-64
Trash & Recycling Receptacle & Lid Accessories .....	64
Trash Cans, Liners .....	65
Stationary Mounts for Trash and Ash Receptacles .....	66

## Waste & Recycling ..... Continued

Trash Can Hangers .....	67
Recycling Arrays — RA Series .....	68
Kolorcans Plastic Trash Receptacles .....	69
Streetscape Receptacle .....	69
Bear Proof Trash Receptacle — BPR Series .....	70
Varmint Defiant Trash Can Cover — VDT Series .....	71
Pet Waste Stations — Pilot Rock & Dogipot .....	72

## Parking ..... 73-79

Bike Racks .....	73-78
Car Stops .....	79
Speed Bumps .....	79

## Site Amenities ..... 80-85

<i>New!</i> Food Lockers .....	80
Lantern Poles .....	81
Traffic Barriers .....	82
Tissue Dispensers .....	82
Planters .....	83
Utility Tables .....	84-85

## Custom Signs ..... 86-88

## Park Grills ..... 89-102

Accessible Grill — ASW Series .....	89
Premier Series Grills — A, B, C, & D Series .....	90-91
Multilevel Grills — N, Q, H, J, K Series .....	92-96
Covered Grills — EC Series .....	97
Shelterhouse Grills — Q3, P, L Series .....	98-99
Grill Station — GS Series .....	100
Grill Accessories .....	100-102
Hot Coal Bin .....	101

## Campfire Rings ..... 103-111

<i>New!</i> FX Campfire Rings .....	103
Campfire Rings FA Series .....	104
Campfire Rings FS Series .....	105
Accessible Firerings — M, LDW, FSDW, FS, FSW Series ..	106-107
Swivel Grate Firerings .....	108
Multilevel Firering — L Series .....	109
Large Group Firering — O Series .....	109
<i>New!</i> ADA Campfire Ring Guidelines .....	109
<i>New!</i> Drop-in Cooking Grate for Firerings .....	110
<i>New!</i> Campfire Ring Covers .....	110
Campfire Ring Accessories .....	111
Utility Shelf .....	111
Heat Shields .....	111
Anchoring Systems for Firerings .....	112

## Anchor Kits ..... 112-113

## Warranty ..... 114

## Ordering Information ..... 114



Federal Supply Schedule

Most products available on GSA Contracts

**OFFICE HOURS:** for R. J. Thomas Mfg. Co., Inc.  
8:00 am to 5:00 pm Central Time, Monday - Friday.  
Closed weekends and holidays.

**Our new site lets you pick the product you want, select custom features for that product and submit a quote request.**

**Here's how it works...**

From the Home Page, select **PRODUCT** for a drop-down menu and click on the product line you are shopping for. This will take you to a landing page of thumbnail images and a brief description for each different style we offer. Then ...

1. Click on a specific design to see detailed Specifications. To customize the item, click on the **CONFIGURE THIS PRODUCT NOW** button.
2. A row of Tabs displaying the feature options will appear. Click to choose your first feature and save it. Return to the Tabs and click on the next feature option. Watch your product Model Number and Unit Price being built with each click and save.
3. When you have configured the product as you want it, enter the quantity and click **ADD PRODUCT TO QUOTE CART**.
4. You can **CONTINUE SHOPPING**, adding multiple configured items to your Quote Cart. Update the Quote Cart if needed. When finished, click **REQUEST A QUOTE**, complete the contact form and Submit the RFQ to us.



When you receive our response confirming the price and providing a freight cost estimate, you can: (a) modify the quote quantities and return it to us to be revised, or (b) click on Finalize to create your Order and submit it to us. Please review your Quote Cart carefully before submitting your order.

**QUICK QUOTE Form:** If you already know what you want, click on the Quick Quote link on the Home Page to go directly to the Quote Form and submit your complete quote request for our response.

Thanks for shopping. We do appreciate your business. Enjoy the Outdoors!

**To Help Us Serve You More Quickly ...**

Please have the following product details ready when contacting us by telephone or e-mail to request additional product information or a Price Quotation. With this information at hand we can serve you more quickly.

**Tables and Benches**

- Model Series:** For example, XT Series picnic table or CXB Series bench.
- Preferred Frame Installation:** Portable, surface mount or embedded frame posts.
- Preferred Frame Finish:** Such as galvanized, or powder coated with color choice.
- Desired Length:** For example, 4 foot, 6 foot, 8 foot, 10 foot, 12 foot.
- Top/Seat/Back Material:** Such as lumber, recycled plastic or thermo-plastic coated steel.
- Wheelchair Accessible:** For example, end or side access on a table.

**Trash and Recycling**

- Model Series:** For example, TRH Series or Amherst Series.
- Desired Shape:** Such as round or square.
- Required Capacity:** Such as 32 gallon or 55 gallon.
- Preferred Material:** For example, lumber, recycled plastic or thermo-plastic coated steel.
- Lid Function:** Collecting trash or recyclables.
- Type of Lid:** Flat or domed, steel or plastic and which color.
- Choice of Mounts:** For receptacle - surface mount or permanent pedestal mount.

**Grills and Firerings**

- Model Series:** Such as A-20 or FS-30.
- Size:** Square inches of cooking area desired or firering diameter.
- Cooking Grate Adjustment:** Infinitely Adjustable, multilevel or single level.
- Installation Method (grills):** Embedded post, bolt down base plate, disk base or caster base.
- Installation Method (firerings):** For example, tip back anchor pins or spade anchors.

With this information at hand, Customer Service can quickly provide you with a complete Model Number for reference and a price quote including all of the requested features. Please help us serve you better by having as much of this product information available when you contact us. Thank you for calling!

**New!**

**New Products Featured in this Catalog**

**Benches**

Pg. 6-7 Sign Benches  
Pg. 11 Armrest for Benches

**Picnic Tables**

Pg. 42 APT Tables with 3"x4" Recycled Plastic

**Trash & Recycling**

Pg. 57 Round Receptacle - side door  
Pg. 58 Square Frame Receptacle  
Pg. 58 Square Receptacle - side door

**Parking**

Pg. 78 Steel Wheels Racks

**Amenities**

Pg. 80 Bear Resistant Food Lockers

**Grills**

Pg. 92-94 Stainless Steel Grate Option on N Series and Q Series Grills  
Pg. 95 N2-2032 B2 Double Grill

**Firerings**

Pg. 103 FX Campfire Rings  
Pg. 110 Drop-in Cooking Grate  
Pg. 110 Campfire Ring Covers

**Coordinate  
Our Products  
for the Look  
You Want!**

Tables, Benches and Trash Receptacles can be coordinated by selecting matching materials... lumber, aluminum, recycled plastic, thermo-plastic coated expanded, perforated or formed steel plate, and the frame finish... and by selecting matching or complimentary colors. See Pages 47-50.

Increase company, organization, school, or sports team visibility by coordinating colors and adding custom signage to benches, tables, and receptacles. See Page 25.



**Pilot Rock® Products are  
Designed & Manufactured  
in the USA - Since 1959**





### Square Frame Benches

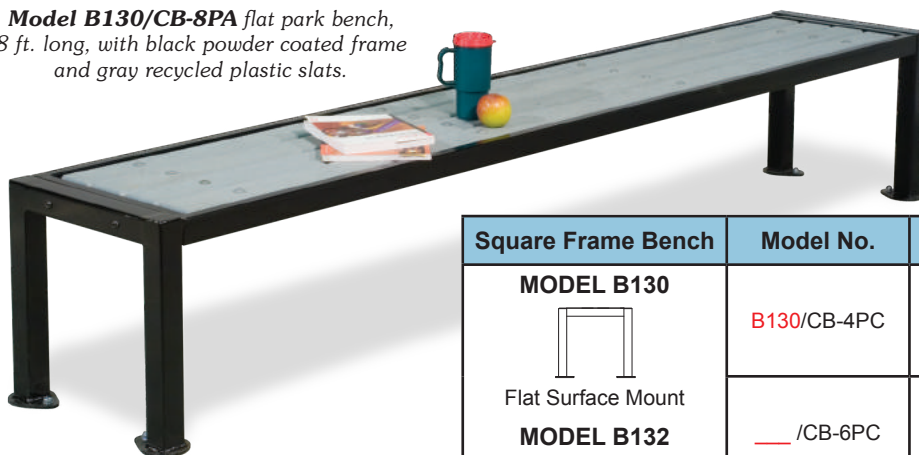

**Model B132/CN-6PC** contour park bench, 6 ft. long, with green powder coat frame finish and cedar colored recycled plastic slats.

**Model B130/CB-8PA** flat park bench, 8 ft. long, with black powder coated frame and gray recycled plastic slats.



Square Frame Bench	Model No.	Length	Seat Material	Frame Finish
<b>MODEL B130</b>  Flat Surface Mount	<b>B130/CB-4PC</b>	4'	1" x 4" and 2" x 4" (nom.) 100% recycled plastic in cedar color (PC) is standard. Other colors available. See Page 50.  Optional Material: 1" x 4" and 2" x 4" (nom.) Construction Heart Redwood (CO). See Page 48.	Powder coat black finish (CB) on all steel components is standard. Other colors available. See Page 47.
<b>MODEL B132</b>  Contour Surface Mount	— /CB-6PC	6'		
	— /CB-8PC	8'		

- **B130 Series** Benches offer a clean cut frame design with inlaid seat and backrest planks.
- Two bench styles:
- **Model B130** is a flat bench.
- **Model B132** includes a backrest and armrests.
- Surface mount installation only. Anchor bolts not included. See Page 113.
- Available in 4, 6 or 8 ft. lengths.
- Rugged all steel, welded component construction. End frames are 2" x 2" x 11 ga. square steel tube. Seat/backrest framework is 1" x 2" x 14 ga. rectangular steel tube, with formed steel channel reinforcements in seat. All open ends are welded closed with steel end caps.
- All steel frame components have a powder coat finish. See Page 47.
- Seat and back inlay materials include: 100% recycled plastic in choice of colors, or construction heart redwood. Seat planks are 2" x 4" nom. and backrest planks are 1" x 4" nom. See Pages 48 and 50. All inlaid planks are installed at the factory.
- Assembly of end frames to seat/backrest components is required.



**Model B132/CU-6PA** contour park bench, 6 ft. long, with blue powder coat frame finish and gray recycled plastic slats.

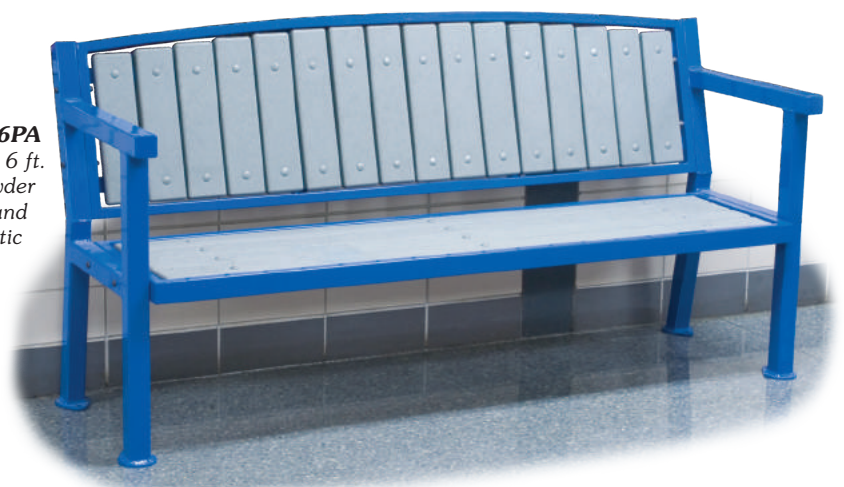

The **CN-Q-36 Series** receptacle is a perfect match for the **B130 Series Benches** and the **T-700 Series Tables**. See Page 44 and 58.

*New!*

# New! Sign Bench

## Contour Seating

Enjoy the

**Get the word out. Promote an event. Recognize achievement, a donation, or memorial. Advertise your business. Generate revenue by selling the sign space on the back of the bench.**



**Model B400/CA-8SP/TA** Sign Bench, surface mount, gray powder coated frames, 8 ft. long, gray thermo-plastic coated contour seat.



**Model B400/CN-6SP/TN** Sign Bench, surface mount, green powder coated frames, 6 ft. long, green thermo-plastic coated contour seat.



The Pilot Rock Sign Bench lets you do all this and more. And it's built to be a public use bench with durable features like:

- All steel fabrication with 10 ga. cut steel formed contour seat and sign frame.
- Thermoplastic seat coating in your choice of colors. See Page 50.
- Frame legs are 2-3/8 in. OD steel pipe.
- Embedded frame post or surface mount installation (anchors not included, see Page 113).
- Powder coat frame finish in your choice of colors. See Page 47.
- Includes seat dividers (bolt on) for 6 ft. and 8 ft. benches.
- Black painted 3/4 in. MDO Sign Board back support for sign.
- **Optional:** Custom made Pilot Rock Sign features: .040 ga. Alumilite aluminum laminate, 1/4 in. thick, polycarbonate core, a 3M vinyl digitally printed graphic material, a 3M protective lamination over the graphic.
- Order/reorder signage from Pilot Rock Signs or your local sign company (use max. 1/4 in. thick material).
- Sign graphic can be replaced as often as you want. Just open the top cap and slide it out.
- Sign is 24 in. tall by 4 ft., 6 ft. or 8 ft. long.
- Hinged top cap closes the sign frame and can be padlocked to secure the sign (padlocks not included — order (2) #PL-1). The sign cannot be removed when cap is closed.
- Includes steel plates on bench frames for a custom decal if desired (identify a bus stop, street address, ownership, etc.). See (D).





▲ Top cap opens for total access to the sign frame. Cap can be padlocked closed. The back support slides in or ► out of the sign frame. (Note: board is not painted to better show detail.)



◀ The sign board slides in front of the back support. Your sign can be replaced as often as you want.



Contour Seating	Model Number Insert Model Number prefix for bench style choice	Length (ft.)	Seat Dividers	Seat Material and Finish	Frame Finish	Sign Size H x W
<b>MODEL B400</b> Surface Mount 	B400/CB-4SP/TB	4	0	Cut 10 ga. steel plate seat and sign frame.  Thermo-plastic coated black (/TB) is standard. Other colors available. See Page 50.	Powder coated black(/CB) is standard. Other colors available. See Page 47.	24" x 48"
	___/CB-6SP/TB	6	2			24" x 72"
<b>MODEL B401</b> Embedded Mount 	___/CB-8SP/TB	8	3			24" x 96"

**Get the word out. Promote an event. Recognize achievement, a donation, or memorial. Advertise your business. Generate revenue by selling the sign space on the back of the bench.**

The Pilot Rock Sign Bench lets you do all this and more. And it's built to be a public use bench with durable features like:

- All steel fabrication: steel sign frame, expanded steel or perforated steel or steel channel seat. Seat is 2-1/2 in. x 12 in. wide (nom.).
- Thermoplastic seat coating in your choice of colors. See Page 50.
- Frame legs are 2-3/8 in. OD steel pipe, with formed channel seat and back support.
- Installation options: Embedded frame post, portable/surface mount, or bolt down base plate mount (anchors not included, see Page 113).
- Hot dip galvanized or powder coat frame finish. See Pages 47-48.
- Black painted 3/4 in. MDO Sign Board back support for sign.
- **Optional:** Custom made Pilot Rock Sign features: .040 ga. Alumilite aluminum laminate, 1/4 in. thick, polycarbonate core, a 3M vinyl digitally printed graphic material, a 3M protective lamination over the graphic.
- Order/reorder signage from Pilot Rock Signs or your local sign company (use max. 1/4 in. thick material).
- Sign graphic can be replaced as often as you want. Just open the top cap and slide it out.
- Sign is 16 in. tall by 4 ft., 6 ft. or 8 ft. long.
- Hinged top cap closes the sign frame and can be padlocked to secure the sign (padlocks not included — order (2) #PL-1). The sign cannot be removed when cap is closed.
- An economic sign bench design.

# New! Sign Bench

## Classic Seating



**Model B410/G-8VR Sign Bench**, portable/surface mount, hot dip galvanized frames, 8 ft. long, expanded steel seat, red thermo-plastic coated seat and sign frame.



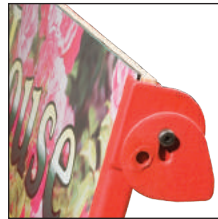

**Model B411/CB-4HU Sign Bench**, embedded mount, black powder coated frames, 4 ft. long, blue thermo-plastic coated perforated steel seat and sign frame.

The back support slides in or out of the sign frame. (Note: board is not painted to better show detail.) Top cap is shown open.



The top cap is hinged at both ends and easily lifts up and tips behind the bench. It's easy to install or replace you sign. The top cap can be padlocked in the closed position to secure your sign until you want to replace it.



Classic Seating	Model Number Insert Model Number prefix for bench style choice	Length (ft.)	Seat Material and Finish	Frame Finish	Sign Size H x W
<b>MODEL B410</b> Surface Mount 	B410/G-4VB	4	Black thermo-plastic coated expanded steel (VB) Other colors available. See Page 49.	Hot dip galvanized finish (/G), or Black powder coat finish (/CB). Other colors available. See Page 47.	16" x 48"
	___/G-6VB	6			16" x 72"
	___/G-8VB	8			16" x 96"
<b>MODEL B411</b> Embedded Mount 	___/G-4HB	4	Black thermo-plastic coated perforated steel (HB) Other colors available. See Page 49.		16" x 48"
	___/G-6HB	6			16" x 72"
	___/G-8HB	8			16" x 96"
<b>MODEL B412</b> Bolt-down Mount 	___/G-6SC/TB	6	Black thermo-plastic coated formed steel channel (SC/TB) Other colors available. See Page 48.		16" x 72"
	___/G-8SC/TB	8			16" x 96"

## Channel Bench

### Our Most Versatile Bench

- **Model CXB** Bench is an extra heavy bench designed to be stronger and more stable with a simple, clean design.
- **Model PCXB** portable/surface mount, 9/16" dia. anchor holes in frame foot.
- **Model SCXB** stationary/embedded frame post installations.
- All welded frame construction: seat/back support channel is die-formed 1/8" thick (11 ga.) steel; frame posts and portable foot are 2-3/8" OD steel pipe.
- Hot dip galvanized finish and fasteners maximize protection from the elements.
- **Optional:** Powder coated frame finish. See Page 47.
- Seat/back plank materials include: 2" x 4" (nom.) pressure treated pine lumber, clear anodized or powder coated aluminum, 2" x 4" (nom.) 100% recycled plastic, coated expanded or perforated steel planks, or formed steel channel with thermo-plastic coat finish. See Pages 48-50.
- Benches can be 4, 6, 8, 10, 15, 16, 21, or 24 feet long (depending on seat/back material selected).
- **Optional:** Armrests can help make bench more accessible. See Page 11.
- **Optional:** Custom engraved lettering is available on recycled plastic; or plastic laminate plaques are available on lumber or recycled plastic; custom punched lettering is available on perforated steel. See Page 25.
- **Optional:** Concrete screw type anchors are available for model PCXB surface mount bench frames. See Page 113.

(Right) **Model PCXB/G-4PN24**, portable, galvanized frames, 4 ft. long, 2" x 4" green recycled plastic planks. Shown with optional engraved identification.

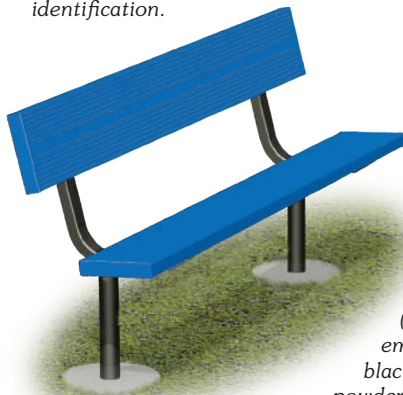

(Left) **Model SCXB/CB-6AU**, embedded mount, 6 ft. long with black powder coat frames and blue powder coat aluminum back and seat.



**Model SCXB3/CU-6PY24** embedded mount, 6 ft. long, three blue powder coated frames, 2" x 4" yellow recycled plastic planks.



**Model PCXB/G-6TP24**, portable, galvanized frames, 6 ft. long, 2" x 4" (nom.) treated pine planks.



**Model SCXB/G-6VW10**, embedded, galvanized frames, 6 ft. long, 2" x 10" brown thermo-plastic coated expanded steel seat and back planks.

STATIONARY / EMBEDDED INSTALLATION				
SCXB	Material	Material Thickness and Width (in.)	Bench Length (ft.)	Configuration
Stationary, Embedded Frame Post	Wood	2 x 4	4, 6, 8	
			15	
	Aluminum	2 x 10	4, 6, 8	
			15	
			21, 24	
	100% Recycled Plastic	2 x 4	4	
			6	
	Expanded Steel	2 x 10	4, 6, 8, 10, 16	
			Perforated Steel	2 x 12
	Formed Steel Channel	2 x 11		





**Model PCXB3/G-15AL**, portable, galvanized frames, 15 ft. long, 2" x 10" (nom.) clear anodized aluminum planks.

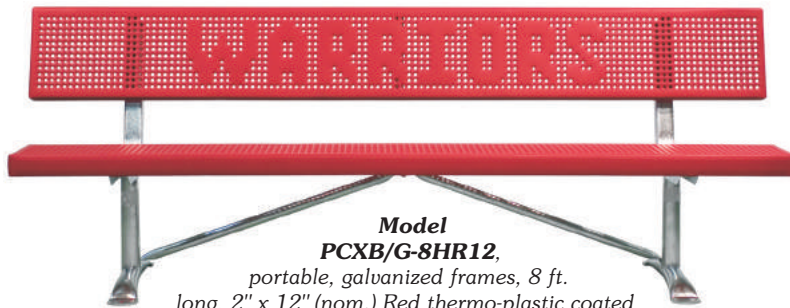

**Model PCXB/G-8HR12**, portable, galvanized frames, 8 ft. long, 2" x 12" (nom.) Red thermo-plastic coated perforated steel seat and back with custom lettering

## Channel Bench

### Our Most Versatile Bench

- **Model CXB** Bench is a durable, uncomplicated style that fits in anywhere — public parks, streetscapes, schools, athletic fields, pools, rec centers, campgrounds, patios and other common areas.
- The CXB bench offers the features to coordinate with school colors, playground designs and any interior or exterior landscape theme.
- **Optional:** Coordinate with picnic tables, trash receptacles, and planters using the same materials.



**Model PCXB/G-6VW10** portable, galvanized frames, 6 ft. long 2" x 10" (nom.) brown thermo-plastic coated expanded steel back and seat, optional **Model AR/TW-7** thermo-plastic coated armrests



**Model PCXB/G-6SC/TN** portable, galvanized frames, 6 ft. long, formed steel channel seat and back components with green thermo-plastic coating.

PORTABLE / SURFACE MOUNT INSTALLATION				
PCXB	Material	Material Thickness and Width (in.)	Bench Length (ft.)	Configuration
 Portable, Surface Mount Frame Foot	Wood	2 x 4	4	
			6, 8	
			15	
	Aluminum	2 x 10	4	
			6, 8	
			15	
			21, 24	
	100% Recycled Plastic	2 x 4	4	
			6	
	Expanded Steel	2 x 10 2 x 12	4	
			6, 8	
	Perforated Steel	2 x 10 2 x 12	10	
16				
Formed Steel Channel	2 x 11	6, 8		



**Model B122/CB-4SP/TA** contour bench, surface mount, black powder coated frames, 4 ft., cut steel plate seat with gray thermo-plastic coating.



**Model B121/CB-4SS/CY** embedded mount flat bench, black powder coated frames, 4 ft. long, with yellow powder coated steel strap seat.

**Model B122/CA-4RR** contour bench, surface mount, gray powder coated frames, 4 ft., perforated steel seat with red thermo-plastic coating.



## Contemporary Steel Bench





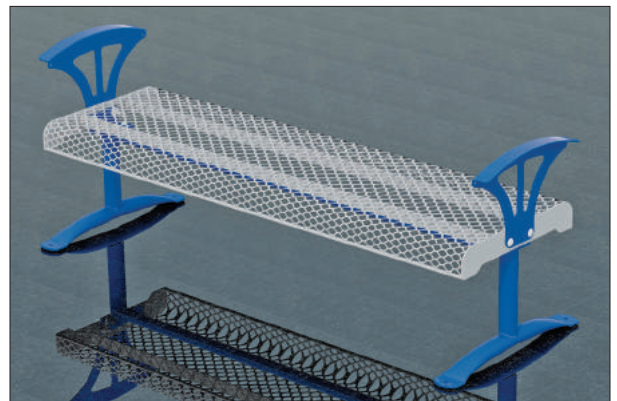

- **Model B120** all steel bench offers a contemporary design with armrests and a comfortable contour or flat bench seat.
- All heavy gauge steel fabricated components: 2-3/8" OD steel pipe frame post and surface foot, 7 ga. steel armrest, and choice of four steel seats.
- Seat materials include: 3/4-#9 expanded steel, 14 ga. perforated steel and 10 ga. cut steel plate each with thermo-plastic coating; or welded steel strap with powder coat finish. See Pages 47-50 for colors.
- Frame posts and armrests are powder coated. See Page 47 for colors.
- Installation: Surface mount and embedded post designs available.
- **Optional:** #ANC3-4 concrete screw anchors for surface mounting. See Page 113.
- Available in 4, 6, or 8 ft. lengths.

(Right) **Model B122/CB-6DU** contour bench, surface mount, black powder coated frames, 6 ft., expanded steel seat with blue thermo-plastic coating.

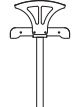

(Below, right) **Model B120/CU-6DA** flat bench, surface mount, blue powder coated frames, 6 ft., expanded steel seat with gray thermo-plastic coating.



STEEL BENCH	MODEL NO. <small>Insert Model Number prefix for bench style choice</small>	LENGTH (FEET)	SEAT MATERIAL	FRAME FINISH	FRAME CONFIGURATION
<b>MODEL B120</b> FLAT SURFACE MOUNT 	B120/CB-4DW	4	Brown Thermo-plastic Coated Expanded Steel (DW) or Perforated Steel (RW) is standard. Other color choices available, see Page 49. Other materials available: Brown Thermo-plastic coated Cut Steel Plate (SP/TW). Other color choices available, see Page 50. Black Powder Coated Steel Strap (SS/CB) Other color choices available, see Page 47.	Powder Coated Black finish (/CB) on frames and armrests is standard. Other colors available, see Page 47.	 Surface Mount
<b>MODEL B121</b> FLAT EMBEDDED MOUNT 	___/CB-6DW	6			
<b>MODEL B122</b> CONTOUR SURFACE MOUNT 	___/CB-8DW	8			 Embedded Mount
<b>MODEL B123</b> CONTOUR EMBEDDED MOUNT 					



## Accessible Bench

- The full-length grab bar across the back of the bench enhances access and transfer to or from this bench.
- All welded frame fabrication: seat/back support channel is die-formed 1/8" thick (11 ga.) steel, frame post and portable/surface mount foot are 2-3/8" OD steel pipe.
- Hot dip galvanized finish is standard.
- **Optional:** Powder coat finish. See Page 47 for colors.
- **Model B110C:** 6 ft., surface mount, grab bar 35" high, seat width 20", seat height 18-1/2" (nom. dimensions), includes 9/16" dia. anchor holes in foot. See Page 113 for anchor bolts.
- **Model B111C:** 6 ft. embedded frame installation.
- Seat/back plank materials include 2" x 4" (nom.) treated pine, or 100% recycled plastic. See Page 50 for color choices.



**Model B110C/CB-6PU24**  
accessible bench, black powder coat frames, 6 ft., 2" x 4" blue recycled plastic seat planks.

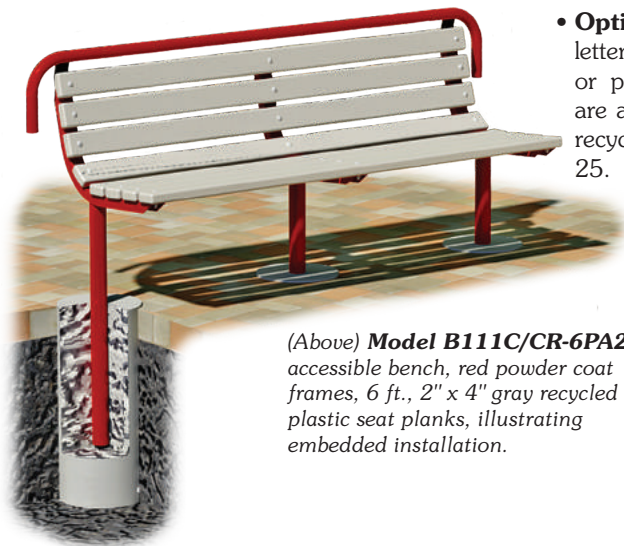

(Above) **Model B111C/CR-6PA24**  
accessible bench, red powder coat frames, 6 ft., 2" x 4" gray recycled plastic seat planks, illustrating embedded installation.

- **Optional:** Custom engraved lettering on recycled plastic; or plastic laminate plaques are available on lumber and recycled plastic. See Page 25.



(Above) **Model B110C/G-6TP24** accessible bench, hot dip galvanized frames, 6 ft., 2" x 4" treated lumber seat planks.

## Armrests available on selected benches

*New!*

<b>Benches</b>	B78, B79	PCXB, SCXB			PCXB, SCXB	PWRB, SWRB, OWRB	WB, OWB	B92
<b>Model #</b>	AR/C◆-13	AR/T◆-2	AR/T◆-7	AR/T◆-9	AR/◆-1	AR/◆-4	AR/◆-6	AR/C◆-10
<b>Bench Seat Material</b>	Expanded or Perforated Steel	2" x 10" or 2" x 12" Perforated Steel	2" x 10" Expanded Steel	2" x 12" Expanded Steel	Wood or Recycled Plastic 2" x 4" or 2" x 10" planks	Wood or Recycled Plastic 3" x 4" timbers	Wood or Recycled Plastic 3" x 4" timbers	Steel Strap or Steel Plate seat Color matches seat (not available for wood or recycled plastic)
<b>Location</b>	Center	End or Center			End or Center			Center
<b>Armrest Material and color</b>	2-3/8" OD steel Pipe /C◆ Indicates color of powder coated finish. Color matches frames. See Page 47.	3/16" x 2" steel /T◆ Indicates color of thermo-plastic coating. Color matches seat. See Page 49.			3/16" x 2" galvanized steel (/G) <b>Optional:</b> Powder coat finish, /C◆ Indicates color of powder coated finish. Color matches frame. Armrest pad matches seat material. See Pages 47-50.			Cast Iron /C◆ Indicates color of powder coated finish. Color matches seat. See Page 47.



**Model PWRB3/G-8PC34** portable, galvanized frames, 8 ft. long, 3" x 4" recycled plastic timbers in cedar color.

(Inset)

**Model SWRB** illustrating embedded frame post installation, and optional armrests.



**Model PWRB/G-6CO34** portable/surface installation, galvanized frames, 6 ft. long, 3" x 4" construction heart redwood timbers, two optional AR/G-4CO armrests.



(Left) **Model OWRB** illustrating standard embedded frame post installation.



(Above) **Model OWRB/P/G-6CO34** surface installation with optional base plate, hot dip galvanized frame, 6 ft. long, 3" x 4" construction heart redwood timbers.

## Contour Benches

Available in two different frame styles:

- **WRB** style bench uses multiple leg posts.
- **Model PWRB** is portable/surface mount.
- **Model SWRB** offers stationary/embedded frame post installations.
- Model WRB Benches offer all welded frame construction, 2-1/2" sq. steel tube for leg post, 3/8" thick steel for seat bracket and portable model frame foot.
- Model WRB Benches can be 4, 6, or 8 ft. long, using 2 or 3 frames (depending on seat material).
- **OWRB** style bench is designed to use just a single large central support post for permanent locations. The single post allows for easier maintenance around bench.
- **Model OWRB** is standard with an embedded post installation.
- **Model OWRB/P** has an optional bolt down base plate.
- Model OWRB benches offer single piece all welded frame construction, a 4" sq. steel tube for the support post, a 2-1/2" sq. steel tube cross-arm, 3/8" thick steel seat brackets, and a 3/8" x 10" sq. base plate for the optional surface installation.
- Model OWRB benches can be 4 or 6 ft. long.

**Both Contour Bench models offer:**

- Seat timber materials include: 3" x 4" (nom.) construction heart redwood lumber (other species available when in stock, please inquire), or 3" x 4" (nom.) 100% recycled plastic available in many colors. See Pages 48, 50.
- Hot dip galvanized finish and galvanized fasteners maximize protection from the elements.
- **Optional:** Powder coated frame finish. See Page 47.
- **Optional:** Armrests help make benches more accessible. See Page 11.
- **Optional:** Engraved personalization on recycled plastic, or custom laminate plaques available on lumber and recycled plastic. See Page 25.
- **Optional:** Anchor kits for surface mounting Models PWRB and OWRB/P. See Page 113.

## Wall Mount Bench

- **Model WMB** Wall Mount Bench is a natural for pools, athletic facilities, locker rooms, building entrances, and parks.
- Bench can be 4 ft. long (two frames), 6 or 8 ft. (three frames), or 8 ft. long with plastic seat planks (four frames).
- Wall bracket is 10 ga. formed/welded channel, galvanized finish.
- **Optional:** Powder coat frame finish in choice of colors. See Page 47.
- Includes galvanized fasteners to attach seat to frame. Does not include wall anchors (each bracket includes three 7/16" dia. wall anchor holes).

Seat Materials	Plank Size (nom.)	Seat Width	Front Edge to Wall
Treated Pine	2" x 4"	11"	14-1/2"
100% Recycled Plastic	2" x 4"	11"	14-1/2"
Aluminum	2" x 10"	10"	15-1/2"
Expanded / Perforated Steel	2-1/2" x 12"	12"	14-3/16"
Formed Steel Channel 6', 8'	2" x 11"	11"	14-1/2"



**Model WMB3/G-6PU24** Wall Mount Bench, 6 ft., three hot dip galvanized frames, 2" x 4" blue recycled plastic seat.



**Model WMB3/CB-6PC24** Wall Mount Bench, 6 ft., three black powder coated frames, 2" x 4" Cedar colored recycled plastic seat planks.



**Model WMB3/G-8VN12** Wall Mount Bench, 8 ft., hot dip galvanized frames, 12" wide green thermo-plastic coated expanded steel seat.



**Model SWB3/G-6PC34**, embedded, galvanized frames, 6 ft. long, cedar colored recycled plastic 3" x 4" (nom.) seat timbers.



(Inset) **Model PWB/G-4PN34**, portable, shown with optional AR/G-6PN armrests.

### Both Trailside Benches offer:

- Hot dip galvanized frame finish and galvanized fasteners.
- **Optional:** Powder coated frame finish. See Page 47.
- Seat timber materials include: 3" x 4" (nom.) construction heart redwood lumber (other species available when in stock, please inquire), or 3" x 4" (nom.) 100% recycled plastic. See Pages 48, 50.
- **Optional:** Concrete screw type anchors are available for Model PWB and OWB/P surface mount bench frames. See Page 113.

## Trailside Benches

- Equally suited to woodland trailside or urban landscape setting.
- **Model WB** Bench offers all welded frame fabrication using 2-1/2" sq. steel tube for leg posts, 3/8" thick steel for seat bracket and portable model frame foot.
- **Model PWB** is portable/surface mount.
- **Model SWB** offers stationary/embedded frame installations.
- Benches can be 4, 6 or 8 feet long, seat is 16" wide (nom.).
- **Optional:** Armrests make benches more accessible. See Page 11.
- **Model OWB** Bench offers a wider seat and a single support structure fabricated using a 4" square steel tube center post with a 2-1/2" sq. cross seat support.
- Two installation methods:  
**Model OWB** with embedded post.  
**Model OWB/P** with 10" sq. base plate for surface anchoring.
- Benches can be 4 or 6 feet long, seat is 24" wide (nom.).



**Model OWB/P/CB-6CO34** surface mount, 6 ft. long, with 3" x 4" (nom.) construction heart redwood seat timbers.



**Model B102/CN-6,**  
green contour bench,  
Design 1.



**Model B100/CB-6**  
black flat bench,  
Design 1.

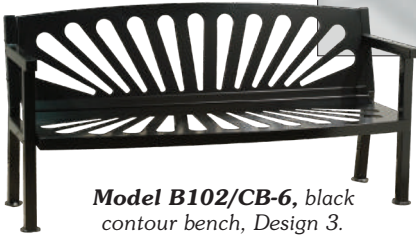

**Model B102/CB-6,** black  
contour bench, Design 3.



**Model B102/CB-6,** black  
contour bench, Design 5  
and custom round metal  
plaque recessed into back.

## Amherst Bench

- All steel fabrication. 3/16" thick (7 ga.) steel seat and back sections. 2" sq. x 10 ga. wall steel tube frame structures.
- 6 ft. long. Two styles: Contour (with back) and flat (no back).
- Portable/surface mount with anchor holes in frame feet.
- Powder coated finish. Choice of colors. See Page 47.
- Simple to assemble. Contour bench has only 4 pieces: seat, back and 2 frames. Flat bench has only 3 pieces.
- **Optional:** Round cast metal plaques. See Page 25.
- **Optional:** Surface anchor kits. See Page 113.
- Match with the Amherst Trash Receptacle. See Page 56.
- Alternate backrest designs available. Some samples ...

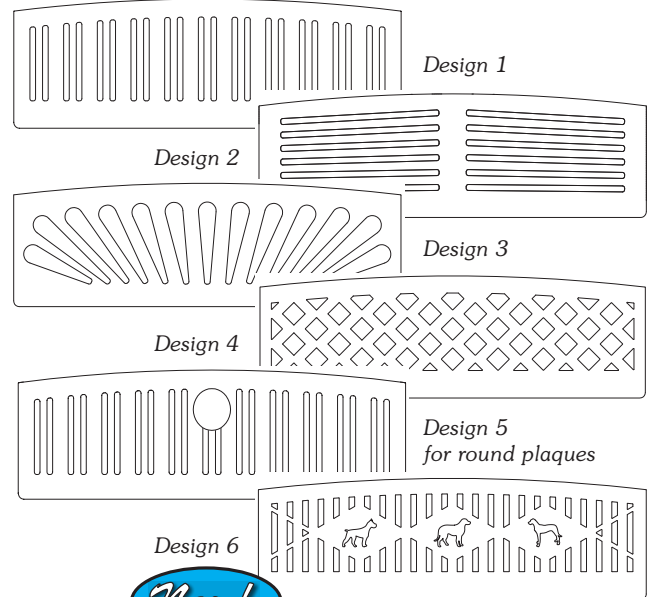

**New!**

## Park Avenue Bench

- Comfortable, classic styling using low maintenance components.
- 2 seating styles: Flat or with backrest in 4, 5, 6, or 8 ft. lengths (8 ft. benches use 3 frames).
- Cast aluminum frames. Available in 6 colors of polyester powder coat finish: hunter green, red, brown, black, dark gray, white.
- Seat and backrest planks are 2" x 4" (nominal) 100% recycled plastic. Available in many colors. See Page 50.
- Match or contrast frame color to seat material colors to create an identity for: schools, clubs, businesses, landscape designs, and sports teams.
- Portable/surface mount frame design. Frame feet include anchor holes to secure to surface.
- **Optional:** Surface anchor kits. See Page 113.



**Model BC4001/CB-6PC,**  
black frames, 6 ft. long,  
cedar colored planks.



(Inset) **Model BC3001/CN-6PN,**  
green frames, 6 ft. long, green planks.



### Gibraltar Bench

- **Model GB** Bench uses ornate, cast iron frames.
- Portable design. Frame feet include anchor holes for fixed positioning. (Anchors not included.) See Page 113.
- Frames are powder coated black.
- 4, 6, or 8 ft. lengths.
- Lumber: 2" x 4" (nom.) seat/back planks of pressure treated #1 southern yellow pine. (8 ft. bench uses 3 frames).
- 100% Recycled Plastic: 2" x 4" (nom.) seat/back planks of 100% recycled plastic available in many colors. See Page 50. (6 ft. bench uses 3 frames. 8 ft. bench uses 4 frames).
- **Optional:** Engraved personalization on recycled plastic. Plastic laminate plaques on lumber and recycled plastic. See Page 25.



**Model GB3/CB-6PC24,** 3 frames, 6 ft. long, 100% recycled plastic 2" x 4" planks in cedar color.

(Inset) **Model GB/CB-4TP24,** 4 ft., 2" x 4" pressure treated pine planks.



**Model GB4/CB-8PA24,** four frames. 8 ft. long, 2" x 4" gray recycled plastic slats.



### Classic Bench

- **Model CLB** Bench incorporates one-piece welded end frames, die formed from structural channel, strong, light weight design. Diagonal braces provide support and stability.
- Portable design. Frame feet include anchor holes for fixed positioning. (Anchors not included. See Page 113.)
- Frames are hot dip galvanized after fabrication for maximum protection from weather.
- Lengths: 4 or 6 ft. long.
- Lumber: 3/4" x 3" Redwood stained hardwood slats. (6 ft. model uses additional formed center channel for support).
- 100% Recycled Plastic: 1" x 3" (nom.) seat/back slats of 100% recycled plastic available in many colors. See Page 50. (4 ft. bench uses extra formed center channel for support. 6 ft. bench uses 3 frames.)

**Model CLB/G-4HW,** 4 ft., redwood stained hardwood slats.



**Model CLB/G-6HW,** 6 ft. long, redwood stained hardwood slats.



**Model CLB3/G-6PC13,** 3 frames, 6 ft. long, 100% recycled plastic slats, cedar color.



**Model CLB/G-4PN13,** 4 ft. long, 100% recycled plastic slats, green color.



**Model B32/CB-4PA34**, surface mount, black powder coated frames, 4 ft. long, with 3" x 4" gray recycled plastic timbers.

## Grey Creek - B30 Series Bench

- Rugged, welded steel component frame structures, offering a wide-surface armrest made with flat steel plate.
- Surface mount or embedded installation.
- Frames can be hot dip galvanized or powder coated with your choice of colors. See Page 47.
- All end frames have armrests for improved accessibility and comfort.
- Contour style or flat designs available in 4, 6, or 8 ft. lengths.
- 6 ft. benches with plastic timbers and all 8 ft. long benches have a center support without armrest.
- Seat timbers are 3" x 4" (nom.) available in: balau hardwood, construction heart redwood, or 100% recycled plastic. See Pages 48, 50.
- **Optional:** Engraved personalization on recycled plastic. Plastic laminate plaques on lumber and recycled plastic. See Page 25.
- **Optional:** Surface mount anchors available. See Page 113.

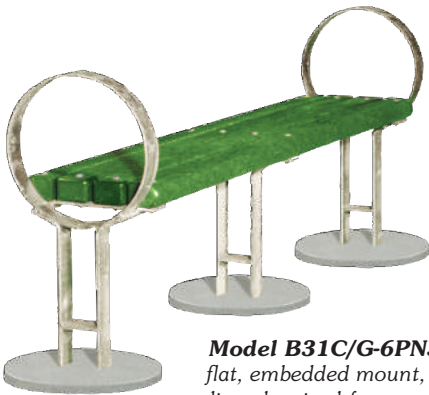

**Model B31C/G-6PN34**, flat, embedded mount, hot dip galvanized frames, 6 ft. long, with 3" x 4" green recycled plastic timbers.



**Model B32C/CN-8IB34**, contour, surface mount, green powder coated frames, 8 ft. long, with 3" x 4" Balau wood timbers.

GREY CREEK SERIES	MODEL NO. <small>Insert Model Number prefix for bench style choice</small>	LENGTH (FEET)	SEAT MATERIAL	FRAME FINISH	FRAME CONFIGURATION	
<b>MODEL B30</b> FLAT SURFACE MOUNT	___/CB-4IB34	4	3" x 4" (nominal) Indonesian Balau Wood (IB) is standard. Other species available include: Construction Heart Redwood (CO).	Powder Coated Black finish (/CB) is standard. Other colors available, see Page 47.		
	___/CB-6IB34	6				
<b>MODEL B31</b> FLAT EMBEDDED MOUNT	___C/CB-8IB34	8				
	___/CB-4PC34	4			3" x 4" (nominal) Cedar colored (PC) 100% Recycled Plastic is standard. Other colors available, see Page 50.	
<b>MODEL B32</b> CONTOUR SURFACE MOUNT	___C/CB-6PC34	6				
	<b>MODEL B33</b> CONTOUR EMBEDDED MOUNT	___C/CB-8PC34				8
				A Hot Dip Galvanized finish (/G) applied after fabrication is also available on this model.		



## Silver Sioux - B40 Series Bench



**Model B42/CN-6PC34**  
contour, surface mount bench, 6 ft. long, with green powder coated frames and 3" x 4" cedar colored recycled plastic timbers

- Welded steel component frame fabrication for strength, round steel tube armrests for a softer appearance.
- Surface mount or embedded installation.
- Frames are powder coated in your choice of colors. See Page 47.
- All end frames have armrests for improved accessibility and comfort.
- Contour style or flat designs available in 4, 6, or 8 ft. lengths.
- 6 ft. benches with plastic timbers and all 8 ft. long benches have a center support without armrest.
- Seat timbers are 3" x 4" available in balau hardwood, construction heart redwood, or 100% recycled plastic. See Pages 48, 50.
- **Optional:** Engraved personalization on recycled plastic. Plastic laminate plaques on lumber and recycled plastic. See Page 25.
- **Optional:** Surface mount anchors available. See Page 113.

**Model B41C/CB-8PD34**, flat, embedded mount bench with black powder coated frames, 8 ft. long, 3" x 4" weathered redwood recycled plastic timbers.



**Model B40/CB-4IB34**, black powder coated frames, 4 ft. long, with 3" x 4" Indonesian Balau wood timbers



**Model B42/CW-4PN34**  
contour, surface mount bench, 4 ft. long, with brown powder coated frames and green recycled plastic timbers

SILVER SIOUX SERIES	MODEL NO. <small>Insert Model Number prefix for bench style choice</small>	LENGTH (FEET)	SEAT MATERIAL	FRAME FINISH	FRAME CONFIGURATION	
<b>MODEL B40</b> FLAT SURFACE MOUNT	___/CB-4IB34	4	3" x 4" (nominal) Indonesian Balau Wood (IB) is standard. Other species available include: Construction Heart Redwood (CO).	Powder Coated Black finish (/CB) is standard. Other colors available, see Page 47.		
	___/CB-6IB34	6				
<b>MODEL B41</b> FLAT EMBEDDED MOUNT	___C/CB-8IB34	8				
	___/CB-4PC34	4			3" x 4" (nominal) Cedar colored (PC) 100% Recycled Plastic is standard. Other colors available, see Page 50.	
<b>MODEL B42</b> CONTOUR SURFACE MOUNT	___C/CB-6PC34	6				
	<b>MODEL B43</b> CONTOUR EMBEDDED MOUNT	___C/CB-8PC34				8



**Model B63/CW-4PC34**, contour, embedded mount bench, brown powder coated frames, 4 ft. long with 3" x 4" cedar colored recycled plastic timbers.

## Riverview - B60 Series Bench







- Heavy steel pipe fabrication. Welded steel components for a stronger frame. Wider curves for a simple, clean appearance.
- Surface mount or embedded installation.
- Frames are powder coated in your choice of colors. See Page 47.
- All frames incorporate armrests for improved accessibility and comfort.
- 2 Bench Styles: Contour or flat. Available in 4 or 6 ft. lengths.
- Seat timbers are 3" x 4" (nom.). Available in: Balau hardwood, construction heart redwood, or 100% recycled plastic. See Pages 48, 50. Plastic timbers available in 4 ft. lengths only.
- **Optional:** Engraved personalization on recycled plastic. Plastic laminate plaques on lumber and recycled plastic. See Page 25.
- **Optional:** Surface mount anchors available. See Page 113.



**Model B60/CN-4IB34** flat, surface mount, 4 ft. bench. Shown with green powder coated frames and 3" x 4" Balau wood timbers.



**Model B63/CU-4PD34**, 4 ft. long, blue powder coat frames, 3" x 4" weathered redwood colored recycled plastic seat timbers.

RIVERVIEW SERIES	MODEL NO. <small>Insert Model Number prefix for bench style choice</small>	LENGTH (FEET)	SEAT MATERIAL	FRAME FINISH	FRAME CONFIGURATION
<b>MODEL B60</b> FLAT SURFACE MOUNT 	___/CB-4IB34	4	3" x 4" (nominal) Indonesian Balau Wood (IB) is standard. Other species available include: Construction Heart Redwood (CO).	Powder Coated Black finish (/CB) is standard. Other colors available, see Page 47.	
<b>MODEL B61</b> FLAT EMBEDDED MOUNT 	___/CB-6IB34	6			
<b>MODEL B62</b> CONTOUR SURFACE MOUNT 	___/CB-4PC34	4	3" x 4" (nominal) Cedar colored (PC) 100% Recycled Plastic is standard. Other colors available, see Page 50.		
<b>MODEL B63</b> CONTOUR EMBEDDED MOUNT 					



(Above) **Model B78/CB-6DN** surface mount, contour, black powder coated frames, 6 ft., thermo-plastic coated expanded steel in green.



*New!*

(Right) **Model B78/CW-6RW** surface mount bench with brown powder coat frames, 6 ft. long, brown thermo-plastic coated perforated steel contour seat.

(Left) **Model B78/CA-6SP/TR** surface mount bench with gray powder coat frames, 6 ft. long, red thermo-plastic coated cut steel contour seat with Design 7 (for dog parks).



**Riverview - B70 All Steel Bench**

- The same frames specifications and features as the Riverview Bench on Page 18, but becomes **Model B70** series.
- Bench styles: Flat or contour.
- Four seat design materials:
  - 3/4-#9 expanded steel with thermo-plastic coating.
  - 14 ga. perforated steel with thermo-plastic coating.
  - 10 ga. cut steel plate pattern with thermo-plastic coating.
  - Steel strap seat with powder coat finish.
- Available in 4, 6 or 8 ft. lengths.
- For colors see Pages 47-50.

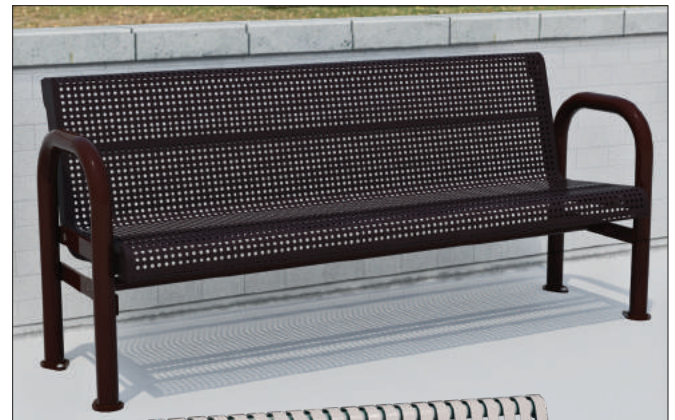
(Left) **Model B77/CN-6DN** embedded, flat, green powder coated frames, 6 ft., thermo-plastic coated expanded steel in green.

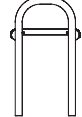
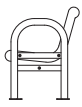
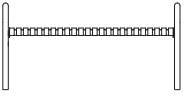
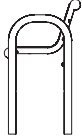

**Model B78/CA-6SS** surface mount, contour, 6 ft. gray powder coated frames and steel strap seat.

RIVERVIEW SERIES	MODEL NO. <small>Insert Model Number prefix for bench style choice</small>	LENGTH (FEET)	SEAT MATERIAL	FRAME FINISH	FRAME CONFIGURATION
<b>MODEL B76</b> FLAT SURFACE MOUNT 	B76/CB-4DW	4	Brown Thermo-plastic Coated <b>Expanded Steel</b> (DW) or <b>Perforated Steel</b> (RW) is standard. Other color choices available, see Page 49.	Powder Coated Black finish (/CB) is standard. Other colors available, see Page 47.	 Surface Mount
<b>MODEL B77</b> FLAT EMBEDDED MOUNT 	___/CB-6DW	6			
<b>MODEL B78</b> CONTOUR SURFACE MOUNT 	___/CB-8DW	8	Other materials available: Brown Thermo-plastic coated <b>Cut Steel Plate</b> (SP/TW). Other color choices available, see Page 50.	 Embedded Mount	
<b>MODEL B79</b> CONTOUR EMBEDDED MOUNT 	___/CB-8DW	8	Black Powder Coated <b>Steel Strap</b> (SS/CB) Other color choices available, see Page 47.		

## Gillette - B80 Series



**Model B80/CN-4SS**  
4 ft. flat bench, steel strap seat,  
green powder coat finish.



**Model B82/CB-6SS**  
6 ft. contour bench, steel strap seat,  
black powder coat finish.



**Model B80/CN-6PY34**  
6 ft. flat bench, green  
powder coat finish, yellow  
recycled plastic seat.



**Model B80/CN-6SP**  
6 ft. flat bench, cut steel  
plate seat, green powder  
coat finish.





**Model B82/CB-4IB34**  
4 ft. contour bench,  
black powder coat frames,  
Indonesian Balau wood seat.

## Park & Streetscape Bench

- Heavy cast iron end frames with a powder coat paint finish. See Page 47.
- Two seat styles: Flat or contour, with surface mount installation. Three lengths: 4 ft., 6 ft., or 8 ft. long. All stainless steel fasteners for assembly.
- Four seat and back material choices:
  - Indonesian Balau Hardwood, in 3" x 4" (nom.) sized timbers. See Page 48.
  - 100% Recycled Plastic in 3" x 4" (nom.) sized timbers, see Page 50.
  - Steel strap fabrication (SS), heavy gauge steel, and all welded construction, with powder coat finish. The frame components and seat structure will be powder coated in the same color.
  - Steel Plate seat design (SP) is a diamond pattern cut and formed from a single sheet of 10 ga. steel, and finished with powder coat paint.
- **Optional:** Engraved personalization on recycled plastic. Plastic laminate plaques on lumber and recycled plastic. Custom cut letters can be incorporated into the Steel Plate (SP) backrest design. Round metal plaques can be recessed into the backrest of the Steel Strap (SS) and Cut Steel Plate (SP) style seat. See Page 25 for signage details.
  - **Optional:** Surface anchor kits. See Page 113.
  - **Optional:** See matching planters on Page 83.



Optional round metal  
plaque available  
on contour steel  
benches.

GILLETTE SERIES	MODEL NO. Insert Model Number prefix for bench style choice	LENGTH (FEET)	SEAT MATERIAL	FRAME FINISH
<b>MODEL B80</b> FLAT SURFACE MOUNT 	B80/CB-4IB34	4	3" x 4" (nominal) Indonesian Balau Wood (IB) is standard.	Powder Coated Black finish (/CB) is standard. Other colors available, see Page 47.
	___/CB-6IB34	6		
	___/CB-8IB34	8		
	___/CB-4PC34	4	3" x 4" (nominal) Cedar colored (PC) 100% Recycled Plastic is standard. Other colors available. see Page 50.	
	___/CB-6PC34	6		
	___/CB-8PC34	8		
<b>MODEL B82</b> CONTOUR SURFACE MOUNT 	___/CB-4SS	4	Heavy gauge steel strap seat (SS) fabrication with all steel component support structure, all welded construction, with powder coat paint finish, see Page 47.	Frame components and seats shall have Black powder coat finish as standard (/CB). Other colors available, see Page 47.
	___/CB-6SS	6		
	___/CB-8SS	8		
	___/CB-4SP	4	Steel Plate seat design (SP) is a diamond pattern cut and formed from a single sheet of 10 ga. steel, and finished with <b>powder coat paint</b> , see Page 47.	
	___/CB-6SP	6		
	___/CB-8SP	8		

## Oak Knoll - B90 Series

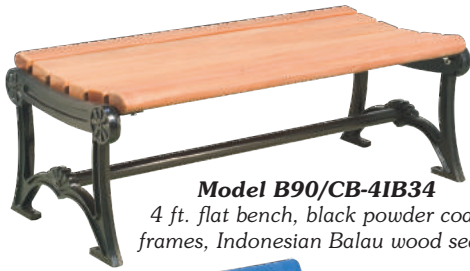

**Model B90/CB-4IB34**  
4 ft. flat bench, black powder coat frames, Indonesian Balau wood seat.



**Model B92/CR-6PU34**  
6 ft. contour bench, red powder coat frames, blue recycled plastic seat.

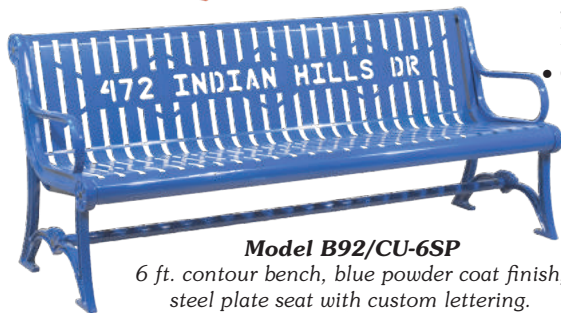

**Model B92/CU-6SP**  
6 ft. contour bench, blue powder coat finish, steel plate seat with custom lettering.

**Model B92/CR-8SS**  
8 ft. contour bench, red powder coat finish, steel strap seat.

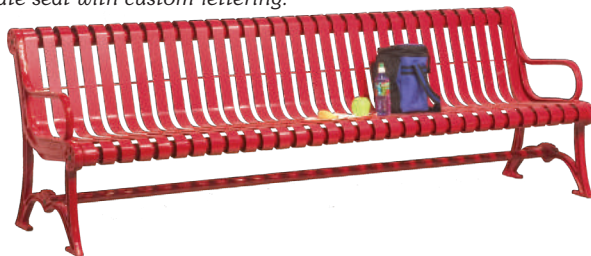



## Traditional Cast Iron Bench

- Heavy cast iron end frames in a traditional design, with a powder coat paint finish available in your choice of colors. See Page 47.
- Two seat styles: Flat or contour, with surface mount installation. Three lengths: 4 ft., 6 ft., or 8 ft. long. All stainless steel fasteners for assembly.
- Four seat and back material choices:
  - Indonesian Balau Hardwood, 3" x 4" (nom.) sized timbers. See Page 48.
  - 100% Recycled Plastic 3" x 4" (nom.) sized timbers. See Page 50 for colors.
  - Steel strap fabrication (SS), heavy gauge steel, and all welded construction, with powder coat finish. The frame components and seat structure will be powder coated in the same color.
  - Steel Plate seat design (SP) is a diamond pattern cut and formed from a single sheet of 10 ga. steel, and finished with powder coat paint.
- **Optional:** Engraved personalization on recycled plastic. Plastic laminate plaques on lumber and recycled plastic. Custom cut letters can be incorporated into the Steel Plate (SP) backrest design. Round metal plaques can be recessed into the backrest of the Steel Strap (SS) and Cut Steel Plate (SP) style seats. See Page 25 for signage details.
- **Optional:** Surface anchor kits. See Page 113.
- **Optional:** Model AR-10 cast iron armrest, bolted in center, is available for Steel Strap and Steel Plate seat designs (not available on wood or plastic). Will be same color as bench. See Page 11.
- **Optional:** See matching planters on Page 83.



**Model B92/CN-6SP**  
6 ft. contour bench, green powder coat finish, cut steel seat, optional Model AR-10 center armrest.

OAK KNOLL SERIES	MODEL NO. <small>Insert Model Number prefix for bench style choice</small>	LENGTH (FEET)	SEAT MATERIAL	FRAME FINISH
<b>MODEL B90</b> FLAT SURFACE MOUNT 	B90/CB-4IB34	4	3" x 4" (nominal) Indonesian Balau Wood (IB) is standard.	Powder Coated Black finish (/CB) is standard. Other colors available, see Page 47.
	___/CB-6IB34	6		
	___/CB-8IB34	8	3" x 4" (nominal) Cedar colored (PC) 100% Recycled Plastic is standard. Other colors available, see Page 50.	
	___/CB-4PC34	4		
	___/CB-6PC34	6		
	___/CB-8PC34	8		
<b>MODEL B92</b> CONTOUR SURFACE MOUNT 	___/CB-4SS	4	Heavy gauge steel strap seat (SS) fabrication with all steel component support structure, all welded construction, with powder coat paint finish, see Page 47.	Frame components and seats shall have Black powder coat finish as standard (/CB). Other colors available, see Page 47.
	___/CB-6SS	6		
	___/CB-8SS	8		
	___/CB-4SP	4	Steel Plate seat design (SP) is a diamond pattern cut and formed from a single sheet of 10 ga. steel, and finished with <b>powder coat paint</b> , see Page 47.	
	___/CB-6SP	6		
	___/CB-8SP	8		

## Locker Room Benches — Built to survive outdoors, these benches will work great indoors, too.



**Model APB/P/G-6VA10**  
floor mount, galvanized frame finish, 6 ft., expanded steel seat plank with gray coating.

## APB/P Series Floor Mount Bench

- Secure, stationary bolt down floor mount. Rectangular steel tube frames.
- Galvanized frames won't rust. Optional colorful powder coat paint finish.
- Wide variety of seat materials. See Pages 47-50 for more details.



**Model RBF/C-6D26** 100% recycled plastic flat bench, 6 ft., as shown with cedar colored frames and weathered redwood colored 2" x 6" seat planks.

## RBF Series 100% Recycled Plastic Frames and Seat Planks

- Plastic components are a solid, dense material that resists mold and mildew. Easy to clean, not affected by cleansers. Many colors to choose from. See Page 50 for more details.
- Portable, moveable for easy floor maintenance. Can be anchored.



**Model WMB/G-4PD24** wall mounted bench, galvanized steel frames, 4 ft. long, 100% recycled plastic seat planks in weathered redwood color.

## WMB Series Wall Mount Bench

- No floor obstructions, easy floor maintenance.
- Galvanized steel frames won't rust. Optional colorful powder coat paint finish.
- Wide variety of seat materials. See Pages 47-50 for more details.



**Model SAB/P/CA-4HR10** floor mount, 4 ft., gray powder coated posts, red thermo-plastic coated perforated steel seat.

## SAB/P Series Floor Mount Bench

- Secure, stationary bolt down floor mount. Round steel pipe frames.
- Galvanized frames won't rust. Optional colorful powder coat paint finish.
- Wide variety of seat materials. See Pages 47-50 for more details.

## Team Bench with an Equipment Deck — provides room for the players & their gear.

- **Series B300** Team Bench available as:  
**Model B302:** 6 or 8 ft. long, 2 frames;  
**Model B303:** 12 or 15 ft. long, 3 frames;  
**Model B304:** 21 ft. long, aluminum only, 4 frames.
- End frames are one-piece, welded construction with a die-formed back, seat, and deck bracket of 2-3/8" x 1-1/2" x 1/8" nom. steel channel, and a 2-3/8" O.D. steel pipe.
- Includes 2" x 10" (nom.) seat and backrest planks for the team. Plus a 20" (nom.) wide (2 planks) full length deck behind the bench for stowing equipment bags and gear.
- Surface mount frame can be anchored to hard surface. The wide frame base makes this a stable bench on turf.
- **Standard:** Hot dip galvanized finish on welded steel component frames.
- **Standard:** Aluminum planks with clear anodized finish.
- **Optional:** Powder coat finish on frames. See Page 47.
- **Optional:** Powder coat finish on aluminum planks.
- **Optional:** Concrete screw type anchors. See Page 113.
- **Optional:** 2" x 10" (nom.) pressure treated #1 southern yellow pine planks instead of aluminum planks.

(Right)  
**Model B302/CB-6AL**  
Team Bench, black powder coated frames, 6 ft. clear anodized aluminum seat and deck planks.



**Model B302/G-8AL**  
at the track meet.



(Right) **B303/G-12TP21** Team Bench, three hot dip galvanized frames, 12 ft. long 2" x 10" treated pine seat and deck planks.



**Model B303/CB-12AY** at the big game.

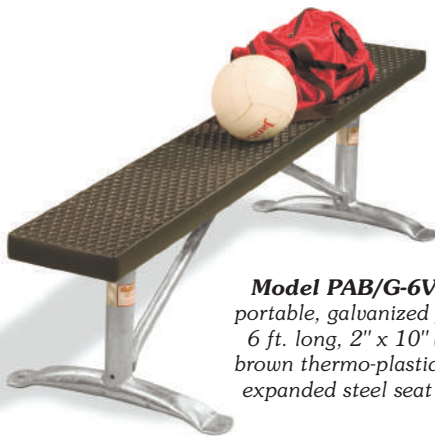

**Model PAB/G-6VW10**, portable, galvanized frames, 6 ft. long, 2" x 10" (nom.) brown thermo-plastic coated expanded steel seat plank.



**Model SAB/G-6AL** stationary embedded post, galvanized frames, 6 ft. long, 2" x 10" clear anodized aluminum seat.

### Athletic Bench — Round Post Portable or Stationary Use

- Durable bench for schools, ball fields, pools, athletic facilities of all kinds.
- **AB Series Bench** is flat (no backrest).
- **Model PAB:** Portable/surface mount, 9/16" dia. anchor holes in frame foot.
- **Model SAB:** Stationary/embedded frame installations.
- **Model SAB/P:** Stationary mount with bolt-down base plate.
- All welded frame construction: 3/16" seat angle; frame posts and portable foot are fabricated from 2-3/8" OD steel pipe.
- Hot dip galvanized finish and galvanized fasteners.
- **Optional:** Powder coated frame finish. See Page 47.
- Available seat materials: Pressure treated #1 southern yellow pine or aluminum, both in 2" x 10" (nom.) planks; formed steel channel (6 and 8 ft. only); thermo-plastic coated expanded steel or perforated steel can be 10" or 12" wide (nom.). See Pages 47-50.
- Benches can be 4, 6, 8, 15, 21, or 24 feet long (depending on seat material selected).
- **Optional:** Thermo-plastic coated perforated steel seats can be lettered for team or field identification. See Page 25.
- **Optional:** Surface anchor kits for PAB and SAB/P frames. See Page 113.



**Model SAB/P/CA-4HR10**, stationary surface mount, gray powder coated frames, 4 ft. long, 10" wide red thermo-plastic coated perforated steel seat plank.

### Athletic Bench — Rectangular Post Stationary Use

- **Model APB** with embedded frame posts provides a secure, permanent location.
- **Model APB/P** frame posts have 3/8" x 8" sq. steel bolt down base plates (anchor bolts not included).
- Bench can be 4, 6, or 8 ft. long.
- Two heavy pedestal posts of 3" x 6" x 1/8" wall rectangular steel tubing. Exposed ends of frame posts are sealed with welded on end caps.
- Hot dip galvanized finish and galvanized fasteners.
- **Optional:** powder coated frame finish available in choice of colors. See Page 47.
- Available seat materials: Pressure treated #1 southern yellow pine, 100% recycled plastic planks, clear anodized or powder coated aluminum, each available in 2" x 10" nom. planks; formed steel channel (6 and 8 ft. only); thermo-plastic coated expanded steel or perforated steel can be 10" or 12" wide (nom.). See Pages 47-50.
- **Optional:** Thermo-plastic coated perforated steel seats can be lettered for team or field identification. See Page 25.
- **Optional:** Surface anchor kits for APB/P frames. See Page 113.

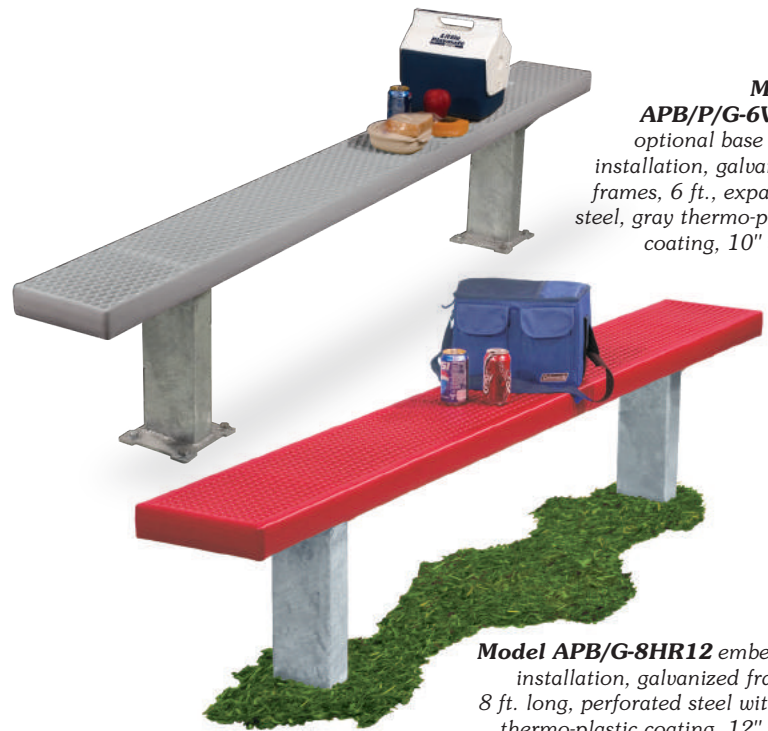

**Model APB/P/G-6VA10** optional base plate installation, galvanized frames, 6 ft., expanded steel, gray thermo-plastic coating, 10" wide.

**Model APB/G-8HR12** embedded installation, galvanized frames, 8 ft. long, perforated steel with red thermo-plastic coating, 12" wide.



**Model RBB/N-6C26** green frames, 6 ft., cedar colored 2" x 6" planks with custom engraved resin filled letters.



**Model RBF/N-4A26** green frames, 4 ft., gray 2" x 6" plastic planks



**Model RBB/A-6A24** gray frames, 6 ft. long, gray 2" x 4" seat and back planks. All gray plastic offers a "concrete" look.



**Model RBF/A-6B24** gray frames, 6 ft., black 2" x 4" plastic planks

## 100% Recycled Plastic Bench

- **RB Series** Benches feature frames and planks molded from 100% recycled plastic.
- The RBB frames (with backrest) and RBF frames (flat) are 3" thick single piece solid molded plastic.
- Seat and back planks can be 2" x 4", 2" x 6", or 2" x 10" nominal dimensions, of solid molded 100% recycled plastic.
- Solid color is formed throughout plastic component. UV stabilizer added for ultraviolet protection.
- Includes stainless steel screws for assembly.
- Two sizes available: 4 ft. long benches use 2 frames; 6 ft. long benches use 3 frames.
- Frames and planks available in many colors. See Page 50.
- Portable by design. Attach to surface for permanent installation with optional anchor brackets. See Page 113.
- **Optional:** Engraved personalization and custom laminate plaques are available. See Page 25.
- **Optional:** See matching planters on Page 83.





## Custom Signage - for Benches, Tables, Trash Receptacles

With custom signage you can recognize memorials, donations, service, special occasions, ownership, schools and teams, anybody or anything you want, promote a service organization, and prevent theft. Message size limits vary by application. Contact us for custom design proof and pricing.

### Engraved Lettering



- Engraved letters are available on benches, tables, and trash receptacles using recycled plastic.
- Letters can be filled with a colorful resin to increase visibility.
- Resin fill is durable, weather resistant, color-fast. Many colors available.



Note: Trademarked names and logos are for purchase by trademark owner only.

### Laminate Plaques



- Made from laminated impact acrylic. 3 ply thickness (1/8"). Plaques can be recessed (on wood and plastic only), or surface applied (on wood, plastic, steel, and aluminum). Recessed plaques on table tops require full edge caulking.
- Plaques are up to 2-1/2" x 12" wide.
- Rated for exterior usage, UV stable and outdoor weatherable. Matte finish, non-glare, contrasting surface and core colors.
- Surface and core color combinations include (surface/core): red/white, red/yellow, safety yellow/black, bright green/white, teal green/white, blue/white, blue/yellow, beige/white. (Other color combinations may be available, please inquire).

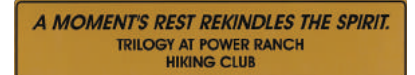

### Metal Plaques



- Silver or bronze colored border and raised letters.
- Two shapes: round (available on steel strap and cut steel plate benches), or rectangular (available on most benches using wood or recycled plastic components).
- Background color is baked on. Choice of 4 colors: black, brown, maroon, green.
- Lightly textured.
- Durable, lightweight, and resistant to the elements and wear.



**Round:** 6" diameter  
Available on B78, B79, B82, B92, B102, B122 and B123 steel strap and cut steel plate contour benches.

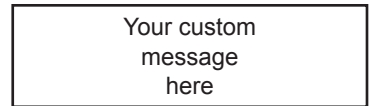

**Rectangle:** 2-1/2" h. x 11-3/4" w.  
Available on most benches using wood or plastic.

### Perforated Steel and Cut Steel Signage



- Perforated 2"x12" steel benches (not contour), tables and receptacles can have custom lettering included. Number and size of letters limited.
- Benches with cut steel plate seats can include a custom cut design.



- Web Site: [www.pilotrock.com](http://www.pilotrock.com)
- E-Mail: [pilotrock@rjthomas.com](mailto:pilotrock@rjthomas.com)

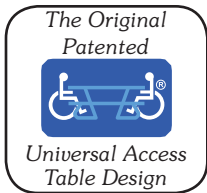

*WXT/G-8DU galvanized frames, 8 ft. long, expanded steel with blue thermo-plastic coating.*

## Universal Access Table — WXT and WUT Series

- **Model WXT** and **Model WUT** Tables provide ADA compliant wheelchair access at both ends.
- Full length seats offer full capacity seating
- Unique frame design includes two wheelchair spaces plus provides proper support under the outside ends of the full length seats.
- Meets or exceeds ADA guidelines for wheelchair access to picnic tables. Both models offer clearances under the table top of 30" wide, 27" high, and 24" total knee and toe clearance (19" knee + 5" toe). Nominal seat height is 18". See Page 31.
- Lifetime frame warranty.
- **Model WXT** frames are constructed of 2-3/8" OD steel pipe, **Model WUT** uses 1-5/8" OD steel pipe. Both designs are welded into a single piece structure for strength and easy assembly.
- Unique patented transverse frame leg under seat makes this a **very stable table**.
- Frame finish: Hot dip galvanized or powder coated. See Page 47 for colors.
- Available lengths: 6, 8, 10, or 12 ft. long (depending on top/seat material selected).

- Top/seat materials available: 2" x 10" untreated or pressure treated pine, aluminum (6 ft. table has nominally shorter seats), 100% recycled plastic (6 and 8 ft. lengths only), thermo-plastic coated expanded steel or perforated steel (6, 8, or 10 ft. lengths only), and formed steel channel (6 and 8 ft. lengths only). See Pages 47-50.



*Model WXT/G-6AL galvanized frames, 6 ft., clear anodized aluminum top/seats (Note: because of lighter weight of this table with aluminum, the seats are nominally shorter than top to improve stability).*

**SNOW LOAD RATED TABLE**  
When equipped with V-Type expanded steel, or H-Type perforated steel top/seats. See Page 32.

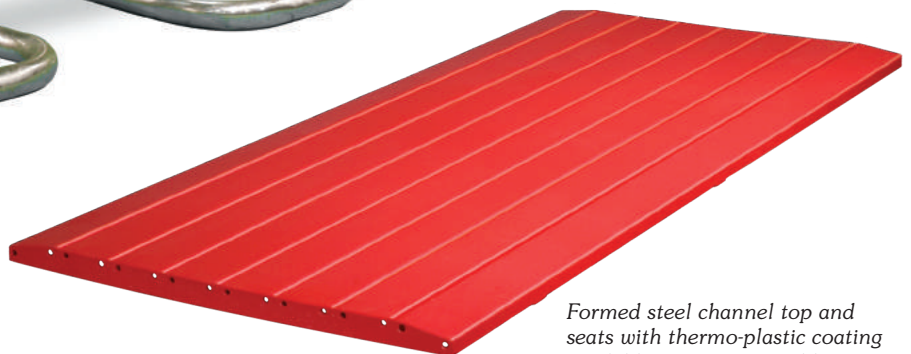

*Formed steel channel top and seats with thermo-plastic coating available on W Series tables.*

U.S. PATENT NOS. D489,539; D490,992; D493,291;  
D496,799; D497,262; 6,918,630



**Model WUTH/G-8UP,**  
galvanized frames, 8 ft.,  
untreated pine lumber.

**Model WXTH/G-6PW**  
galvanized frames, 6 ft.,  
100% recycled plastic  
planks in brown color.

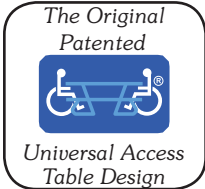

**Universal  
Access  
with  
Square  
Frame —  
WPTS Series**



**Model WPTS/G-8VW,**  
galvanized frames, 8 ft.,  
thermo-plastic coated expanded  
steel with brown color.

**Universal Access Table  
with Raised Top —  
WXTH and WUTH Series**

- **Model WXTH** and **Model WUTH** Tables offer the same **patented** accessible design features of WXT and WUT Tables. **Lifetime frame warranty.**
- Table top is raised to allow most wheelchair armrests to fit under it for a closer approach. This is an advantage for some persons in wheelchairs and persons with certain physical restrictions.
- Exceeds ADA guidelines for wheelchair access to picnic tables. Both models offer clearances under table top of 30" wide, 24" total knee and toe clearance (19" knee + 5" toe), plus increases under table clearance to 31". Nominal seat height is 19". See Page 31.
- Frame finishes: Hot dip galvanized or powder coated. See Page 47 for colors.
- Available lengths: 6, 8, 10, or 12 ft. long (depending on top/seat material selected).
- Top/seat materials available: 2" x 10" untreated or pressure treated pine, aluminum (6 ft. table has nominally shorter seats), recycled plastic (6 and 8 ft. only), thermo-plastic coated expanded or perforated steel (6, 8, or 10 ft. only) or formed steel channel (6 and 8 ft.). See Pages 47-50.

- **Model WPTS** Tables offer all the same accessible design features of the W Series Tables (See Page 26) plus adds portability to our popular APT Series multi-pedestal tables.
- Accessible to wheelchairs at both ends plus full length seats for maximum capacity seating.
- Model WPTS 8 ft. provides ADA compliant wheelchair access, with clearances under the table top of 30" wide, 27" high, and 24" total knee and toe clearance (19" knee + 5" toe). Seat height, 18" (nom.).
- Available lengths: 6 or 8 ft. long.

- Frames constructed of: 3" x 6" (nom.) x 1/8" wall rectangular steel tube for top and seat supports, connected with 2-1/2" (nom.) x 1/8" wall square steel tube. Welded into a single piece for strength and easy assembly.
- Frame Finishes: Hot dip galvanized or powder coated. See Page 47.
- Top/seat materials offered: 2" x 10" untreated or pressure treated pine, aluminum, 100% recycled plastic, or thermo-plastic coated expanded or perforated steel, or formed steel channel. See Pages 47-50.

**SNOW LOAD RATED TABLE**  
When equipped with V-Type expanded steel, or  
H-Type perforated steel top/seats. See Page 32.

**U.S. PATENT NOs. D489,539; D490,992; D493,291;  
D496,799; D497,262; 6,918,630**

- Web Site: [www.pilotrock.com](http://www.pilotrock.com) •
- E-Mail: [pilotrock@rjthomas.com](mailto:pilotrock@rjthomas.com) •

## Heavy Duty — UT Series

- **Model UT** Tables are designed for most public applications. Built rugged, but with less weight, easier to move.
- Model UT Tables feature our nontip, nontrip, walk through design. Won't tip even if all persons sit on one side. Easy walk through access. "Skid" design permits movement without damage to turf.
- All welded 1-5/8" OD steel pipe end frames (1.660" OD, 11 ga. wall, 1-1/4" ID nom. pipe specifications). Top/seat mounting angles are 2" x 2" x 3/16" steel angles.
- Frames supported by diagonal braces of 1-5/16" OD steel pipe attached to steel center channel. All 3/8" dia. galvanized carriage bolt fasteners. **Lifetime warranty.** See Page 114.
- Standard finish: Hot dip galvanized after fabrication.
- Optional frame finish: Powder coating (in place of galvanized finish). See Page 47 for colors.
- Model UT Tables offer 30" nom. table height; 18" nom. seat height. Tables can be 6, 8, 10, or 12 ft. long (depending on top/seat material selected).
- Top/seat materials available: 2" x 10" untreated or pressure treated #1 southern yellow pine, aluminum, 100% recycled plastic (6, 8, and 10 ft. lengths only), thermo-plastic coated expanded or perforated steel (6, 8, or 10 ft. lengths only) or formed steel channel (6 and 8 ft. only). See Pages 47-50.
- Wheelchair Accessible Table Designs available: end access, side access, and raised top with end access. See Pages 30 and 31.
- King Size Table for large group meeting areas and shelter houses. Using 3 frames table can be 10 or 12 ft. long.
- Childrens Size Table with dimensions to fit children and their activities. See Page 33.



**Model UT/CN-6UP**, green powder coated frames, 6 ft., untreated pine lumber.



**Model UT/G-8RW**, galvanized frames, 8 ft., thermo-plastic coated perforated steel in brown.

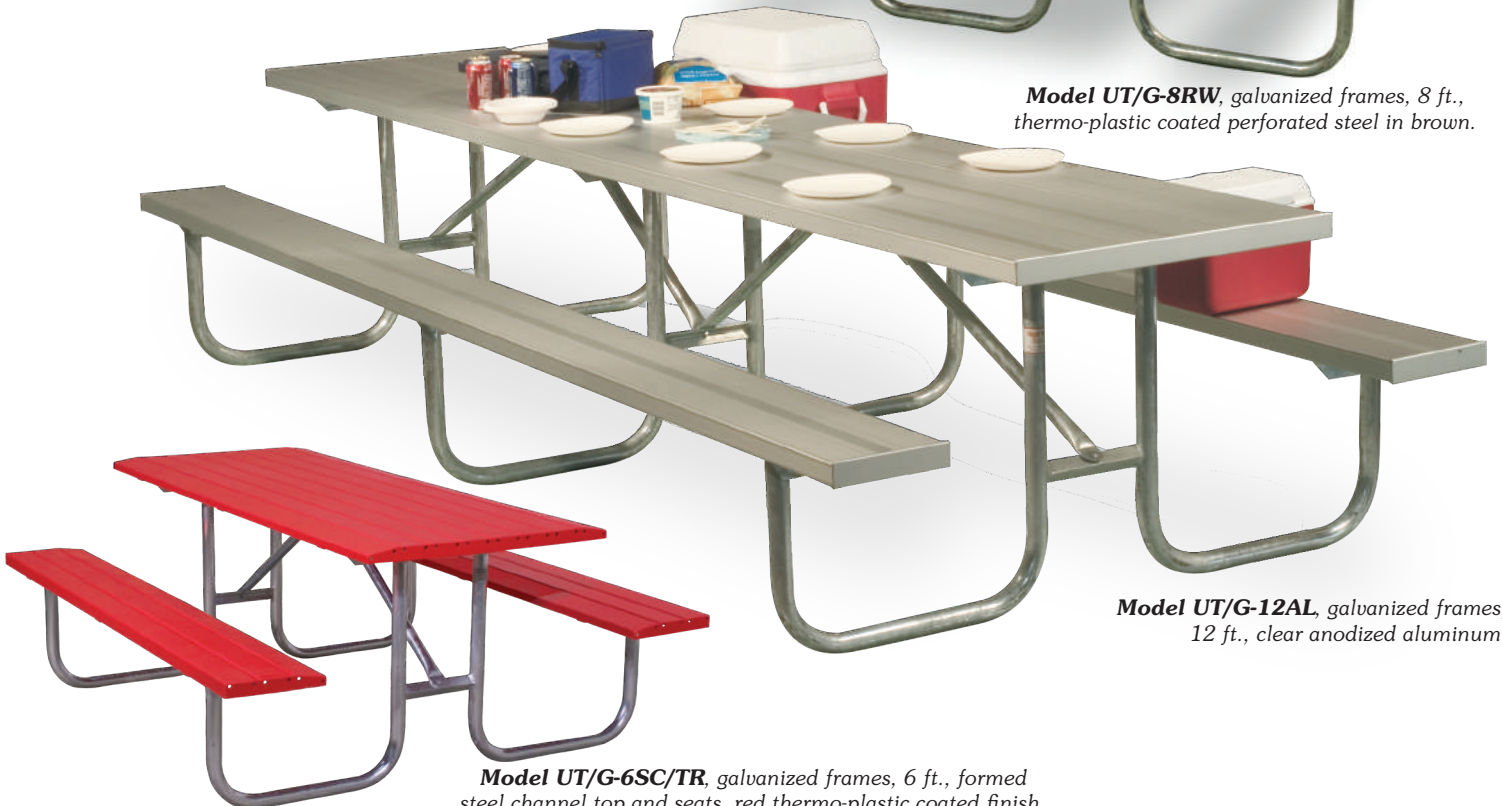

**Model UT/G-12AL**, galvanized frames, 12 ft., clear anodized aluminum.

**Model UT/G-6SC/TR**, galvanized frames, 6 ft., formed steel channel top and seats, red thermo-plastic coated finish.

## Extra Heavy Duty — XT Series

- **Model XT** Tables designed and constructed specifically for heavy use areas where unusually difficult service may be required.
- Model XT Tables feature our nontip, nontrip, walk through design. Won't tip even if all persons sit on one side. Easy walk through access. "Skid" design permits movement without damage to turf.
- All welded 2-3/8" OD steel pipe end frames (2.375" OD, 11 ga. wall, 2" ID nom. pipe specifications). Top/seat mounting angles are 2" x 2" x 3/16" steel angles.
- Frames supported by diagonal braces of 1-5/16" OD steel pipe attached to steel center channel. All 3/8" dia. galvanized carriage bolt fasteners. **Lifetime warranty.** See Page 114.
- Standard finish: Hot dip galvanized after fabrication.
- Optional frame finish: Powder coating available (in place of galvanized finish). See Page 47 for colors.
- Model XT Tables offer 30" nom. table height; 18" nom. seat height. Tables can be 6, 8, 10, or 12 ft. long (depending on top/seat material selected).
- Top/seat materials available: 2" x 10" untreated or pressure treated #1 southern yellow pine, aluminum, 100% recycled plastic (6, 8, and 10 ft. only), thermo-plastic coated expanded or perforated steel (6, 8, or 10 ft. only) or formed steel channel (6 and 8 ft. only). See Pages 47-50.
- Wheelchair Accessible Table Designs available: End access, side access, and raised top with end access. See Pages 30 and 31.
- King Size Table for large group meeting areas and shelter houses. Requires 3 frames for 10 or 12 ft. tables.



**Model XT/G-6UP**, galvanized frames, 6 ft., untreated pine lumber.



**Model XT/G-8VN**, galvanized frames, 8 ft., thermo-plastic coated expanded steel in green.

**Model XT/G-12UP**, galvanized frames, 12 ft., untreated pine lumber.



**Model XT/G-8AR**, 8 ft. long, hot dip galvanized frames, red powder coated aluminum top and seats.

- Web Site: [www.pilotrock.com](http://www.pilotrock.com) •
- E-Mail: [pilotrock@rjthomas.com](mailto:pilotrock@rjthomas.com) •

**SNOW LOAD RATED TABLE**  
When equipped with V-Type expanded steel, or H-Type perforated steel top/seats. See Page 32.



**Model XT/G-6PU**, galvanized frames, 6 ft., 100% recycled plastic in blue color.



All of these Pilot Rock tables meet ADA guidelines for wheelchair accessibility. See Page 31.

## End Accessible Tables

- **Models UT** (1-5/8" OD) and **XT** (2-3/8" OD) table frames can be used. See Pages 28-29. Tables offer 30" nom. table height; 18" nom. seat height.
- Top is extended 2 ft. beyond seats on one or both ends. Extended top is supported by a special diagonal brace and steel channel.
- Available lengths and materials:
  - 6 ft. seats and 8 ft. top (extended on one end, /E), with all materials.
  - 8 ft. seats and 10 ft top (extended on one end, /E) available with lumber, aluminum and recycled plastic.
  - 6 ft. seats and 10 ft. top (extended on both ends, /EE) available with lumber or aluminum only.

## Raised Top, End Accessible Tables

- **Models UTH** (1-5/8" OD) and **XTH** (2-3/8" OD) are designed to provide more clearance under the table top to allow most wheelchair armrests to fit under it for a closer approach. Higher frames provide an under table clearance of 30". Other table specifications same as UT and XT. See Pages 28-29.
- Top is extended 2 ft. beyond seats on one or both ends. Extended top is supported by a special diagonal brace and steel channel.
- Available lengths and materials:
  - 6 ft. seats and 8 ft. top (extended on one end, /E) with all materials.
  - 8 ft. seats and 10 ft top (extended on one end, /E) available with lumber, aluminum and recycled plastic.
  - 6 ft. seats and 10 ft. top (extended on both ends, /EE) available with lumber or aluminum only.

## Side Accessible Tables

- **Models UT** (1-5/8" OD) and **XT** (2-3/8" OD) table frames can be used. See Pages 28-29. Tables offer 30" nom. table height; 18" nom. seat height.
- Side Access Tables (/SA) take out a section of seating along side of table to provide wheelchair access right in the middle of activities.
- 6 ft. and 8 ft. tables provide one side opening. Two one-person seats are located on either side of wheelchair. These tables can comfortably seat 6 to 7 people.
- 10 and 12 ft. tables feature two locations for wheelchairs, diagonally opposite each other. ADA guidelines require two wheelchair spaces on these larger tables. Each side includes a shorter one-person seat plus a longer seat to fit 3-4 persons. These tables can comfortably seat 10 to 12 people.
- Diagonal braces are used to support and reinforce the table structure. Brace positioning allows wheelchair spaces to meet ADA clearance guidelines of 30" wide, 27" under table (ground to bottom of table top), and 24" total knee and toe clearances (19" knee + 5" toe).
- Materials available: Lumber, aluminum; or recycled plastic (6, 8, and 10 ft only).



**Model XT/G-6PN/E** 2-3/8" OD galvanized frames, 6 ft. seats, 8 ft. top extended 2 ft. one end, 100% recycled plastic in green color.



**Model UTH/G-6DU/E**  
1-5/8" OD galvanized frames, 6 ft. seats, 8 ft. top is raised and extended 2 ft. one end, thermo-plastic coated expanded steel in blue.



**Model XT/G-6AL/SA** 2-3/8" OD galvanized frames, 6 ft., clear anodized aluminum, side access opening for one wheelchair.



**Model UT/G-12AL/SA**  
1-5/8" OD galvanized frames, 12 ft., clear anodized aluminum, two side access openings for two wheelchairs.

Pilot Rock accessible tables meet or exceed the guidelines as presented in the Federal Register, Dated June 20, 2007, Part II Architectural and Transportation Barriers Compliance Board, the ADA guidelines to wheelchair clearances for "picnic table" access as described on: Page 27, Part T306.2 Wheelchair spaces and Page 41, Part T404.2.5 Width.

# Accessibility Compliance

## Compare Picnic Tables for Compliance with ADA Guidelines for Wheelchair Accessibility.

The ADA Guidelines for wheelchair access to picnic tables are as follows\*: “Wheelchair spaces shall provide knee space at least 27 inches (685 mm) high, 30 inches (760 mm) wide, and 19 inches (485 mm) deep. Toe clearance 9 inches (230 mm) high minimum shall extend an additional 5 inches (127 mm) minimum from the knee clearance.” And “Toe clearance shall be 30 inches (760 mm) wide minimum.”

These dimensions create a Clearance Box that must fit under the picnic table to be an ADA compliant table. Many popular tables are not compliant.

Below are illustrations of some of the Pilot Rock brand ADA compliant tables compared to a few other brands which claim to be accessible. We have installed our ADA Clearance Box under each table to see if it meets the access requirements. Judge for yourself.

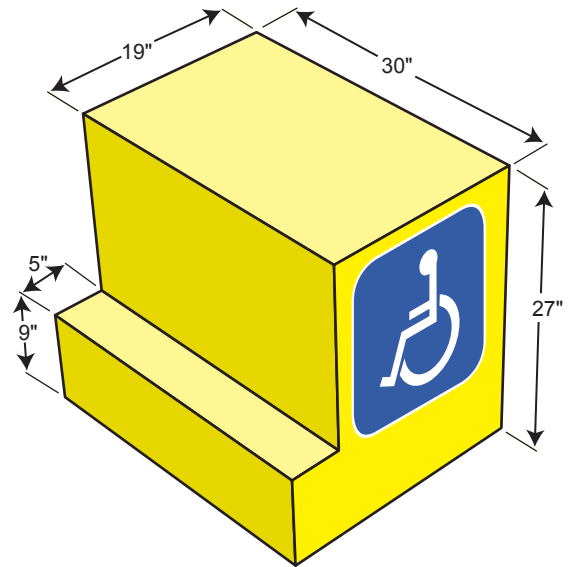

The ADA Clearance Box built to the required dimensions, including knee and toe clearances, approaches a **Pilot Rock** W Series Universal Access picnic table.



The ADA Clearance Box fits completely underneath the W Series table end. This **Pilot Rock** table provides all the required vertical and horizontal knee and toe clearances. (Note: this unique table design is covered under 6 patents.)



**Pilot Rock** UT and XT Series tables with a two-foot extended top (denoted by “E” in the model number) provides more than enough knee/toe space under the top to comply with ADA.



**Pilot Rock** AT Series A-frame tables are available with a top extended one foot at each end. This provides adequate knee clearance under the table top, and the A-frame space provides the toe clearance needed to meet the guidelines.



This traditional steel frame table claims to be wheelchair accessible with an 8 ft. top centered on 6 ft. frames (top extended one foot at each end). Many different brands offer this top/seating configuration as “accessible”.

But the Clearance Box doesn’t fit! There is not enough knee clearance (19”) and toe clearance (plus 5” = 24” total) to provide complete wheelchair access under the table top.

**This table design does NOT comply with ADA.**



The manufacturer of this table claims “universal access” but notice that the ADA Clearance Box does not fit completely under the top. The frames get in the way of the required 5” x 9” x 30” toe clearance space, so it does not provide total wheelchair access under the table.

**This table design does NOT comply with ADA.**



This table brand does provide enough knee and toe clearance under the top to meet ADA guidelines. But the inadequate frame design (less than transverse frame angle bends) and the light weight materials used to construct the frames and top/seats create instabilities in this table which make it a problem for the public to use safely.



**NOTE:** There is no such thing as an “ADA Approved” or “ADA Certified” picnic table. There is no approving or certifying organization. Compliance with the ADA guidelines is left to the manufacturer and the customer.

\* According to the Draft Final Accessibility Guidelines for Outdoor Developed Areas, the Pilot Rock picnic table is designed to comply with accessibility guidelines for clear ground space, 1011.2.1, and wheelchair space, 1011.4, including knee and toe clearance complying with Section 306 of the ADA-ABA accessibility guidelines.

For more information on the “Architectural and Transportation Barriers Compliance Board” Federal Register contact: Bill Botten, Office of Technical and Information Services, Architectural and Transportation Barriers Compliance Board, 1331 F St. NW Suite 1000, Washington, DC 20004-1111. Ph: 202-272-0014; e-mail: botten@access-board.gov; web site www.access-board.gov.



## SNOW LOAD and EXTREME LOAD RATED TABLES

### 500 lbs. to 1420 lbs. Per Square Foot Snow Load Capacity!

These Pilot Rock brand picnic tables have been designed and independently tested ...by an independent lab and a state university... to withstand high elevation snow loads and other extreme conditions. To achieve the following ratings, these steel frame tables must be equipped with our V-Type expanded steel or H-Type perforated steel top and seat structures. Standard and accessible tables are available. Remember ... the rating is Per Square Foot, not per table! When the snow melts these tables will be ready to use again.

**Models WXT and WXTH** Universal Access Tables (see Page 26-27) in 6 ft. or 8 ft. lengths, with V-Type expanded steel or H-Type perforated steel top/seats.



**Model WPTS** Universal Access Table (see Page 27) in 6 ft. or 8 ft. lengths, with V-Type expanded steel or H-Type perforated steel top/seats.

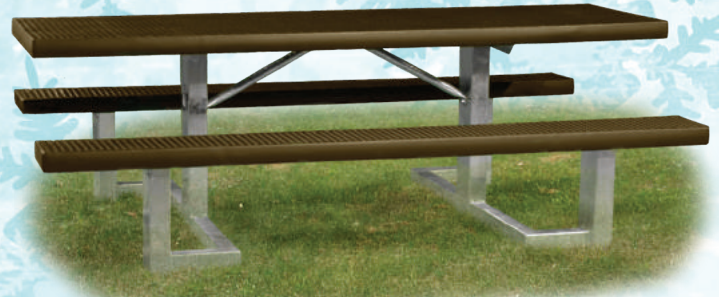

**1420 lbs.  
Per Square  
Foot**



Maybe it doesn't snow where you are? Just think how well these tables will hold up to public exposure in your parks!

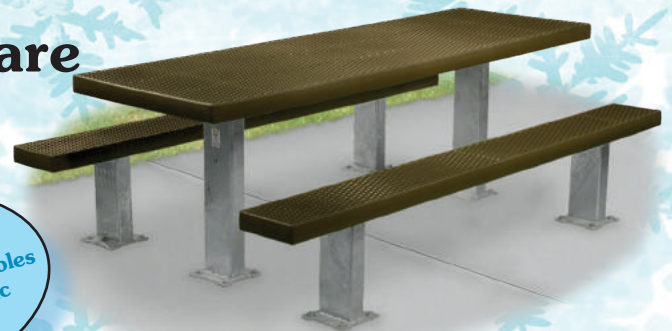

**Model XT** Standard Tables (see Page 29) in 6 ft. or 8 ft. lengths, with V-Type expanded steel or H-Type perforated steel top/seats.

**Model APT** Multi-Pedestal Tables and **APT-X** Utility Tables (see Page 42, 85) in 6 ft. or 8 ft. lengths, with V-Type expanded steel or H-Type perforated steel top/seats.



### 948 lbs. Per Square Foot

**Models XT/E and XTH/E** Extended End Wheelchair Accessible Tables (see Pages 29 and 30) with 8 ft. top and 6 ft. seats. The 2 ft. extension on the table top was tested to withstand over 948 lbs. per sq. ft. without failure.

### 500 lbs. Per Square Foot on a Recycled Plastic Table

**Model WAT-8** A-Frame Table (see Page 35) 8 ft. long and wheelchair accessible at both ends. The table structure uses Recycled Plastic leg posts and top/seat planks and incorporates steel braces for support. This table was tested to hold over 500 lbs. per sq. ft. load without failure.



## Kid's Tables — Rectangular, Square and Round

- Tables are proportionally scaled to fit children up to 10 or 11 years old.
- Seats are 12" high. Top is 22" high.
- Frame fabrication and top/seat construction are identical to the standard size tables. All welded construction with appropriate bracing and supports. Children can be hard on furniture. You need outdoor picnic tables built to take it.



**Model UTK/G-8RU**  
galvanized frames, 8 ft., blue thermo-plastic coated perforated steel top and seats.

## Model UTK – Rectangular Table

- UTK Tables can be 4, 6 or 8 ft. long. Built to same specifications as UT Tables. See Page 28.
- Standard frame finish: Hot dip galvanized after fabrication.
- Optional frame finish: Powder coating. See Page 47 for colors.
- Top/seat materials available: 2" x 10" (nom.) untreated or pressure treated #1 southern yellow pine, aluminum, 100% recycled plastic, and thermo-plastic coated expanded or perforated steel or formed steel channel (6 and 8 ft. lengths only). See Pages 47-50.

**Model UTK/G-4UP**  
galvanized frames, 4 ft., untreated pine lumber.



## Model SQTK — Square Table

- SQTK Tables provide a 48" square top and 4 bench seats. Built to same specifications as SQT-4 Tables. See Page 38.
- Standard frame finish: Hot dip galvanized after fabrication.
- Optional frame finish: Powder coating. See Page 47 for colors.
- Top/seat materials available: 2" x 10" (nom.) untreated or pressure treated #1 southern yellow pine, aluminum, 100% recycled plastic, and thermo-plastic coated expanded or perforated steel. See Pages 47-50 for colors.



**Model SQTK/CW-4PY** brown powder coated frames, 4 ft., yellow recycled plastic planks.

## Model T104K — Round Table

- T104K Tables provide a 48" round top and 4 curved seats. Built to same specifications as T100 Tables. See Page 40.
- Standard frame finish: Hot dip galvanized after fabrication.
- Optional frame finish: Powder coating. See Page 47 for colors.
- Top/seat materials available: 100% recycled plastic and thermo-plastic coated expanded or perforated steel. See Pages 49-50 for colors.

**Model T104K/CY-4DR** yellow powder coated frames, 4 ft., red thermo-plastic coated expanded steel top and seats.



## A-Frame Table — AFT Series All Wood Traditional A-Frame Table



**Model AFT-6TP** all wood, 6 ft., A-frame table, treated pine lumber.



**Model AFT-8TP**, all wood, 8 ft. long, A-frame table, treated pine lumber, wheelchair accessible at both ends.

- **Model AFT** is your traditional ALL WOOD A-frame style picnic table. All components and bracing are pressure treated #1 southern yellow pine: 4" x 6" leg posts, 2" x 4" and 2" x 6" connecting and support braces, and 2" x 10" top/seat planks (nom. dimensions).
- Model AFT frames are assembled using 3/8" dia. carriage bolts for superior clamping force to keep the table solid. Top/seat planks are secured with stainless steel screws. All lumber is precision drilled to facilitate assembly. All fasteners are included.
- Dimensions: 6 ft. or 8 ft. long, 30-1/4" table height, 17-3/4" seat height (nominal). The 8 ft. long table is wheelchair accessible and provides ADA compliant wheelchair access points at both ends. See Page 31.

## A-Frame Table — AFT Series All Plastic Traditional A-Frame Table



**Model AFT/W-8PW** all plastic, 8 ft. long, A-frame table with brown recycled plastic seats, top, and frames

**Model AFT/B-6PC** all plastic, 6 ft. long, black frames, cedar colored top/seat planks.

- **Model AFT** is your traditional ALL PLASTIC A-frame style picnic table. All components and bracing are 100% recycled plastic: 4" x 6" leg posts, 2" x 4" and 2" x 6" connecting and support braces, and 2" x 10" top/seat planks (nom. dimensions).
- Standard Colors: Brown or black leg posts and braces, and Cedar color top/seat planks. Other plank colors are available. See Page 50.
- Model AFT frames are assembled using 3/8" dia. carriage bolts for superior clamping force to keep the table solid. Top/seat planks are secured with stainless steel screws. All plastic lumber is precision drilled to facilitate assembly. All fasteners are included.
- Dimensions: 6 ft. or 8 ft. long, 30-1/4" table height, 17-3/4" seat height (nominal). The 8 ft. long table is wheelchair accessible and provides ADA compliant wheelchair access points at both ends. See Page 31.

## A-Frame Table — AT Series Steel Braces Make a Stronger Table

- **Model AT** Tables incorporate pre-galvanized steel braces and cross supports for a stronger A-frame design. A traditional table modified to withstand public and commercial use.
- Frames are supported by diagonal braces of 1-5/16" OD galvanized steel pipe attached to a steel center channel under the table top. All 3/8" dia. galvanized carriage bolts (not lag screws) are provided for assembly.
- Model AT Tables use 4" x 6" (nom.) leg posts, and 2" x 10" (nom.) top/seat planks. Choose either pressure treated #1 southern yellow pine, or 100% recycled plastic. See Pages 48, 50.
- 6 ft. or 8 ft. long (2 frames) using lumber or recycled plastic; 12 ft. long (3 frames) using treated pine only.
- Wheelchair Accessible: 6 ft. long seats with 8 ft. long top extended 1 ft. at each end provides ADA compliant wheelchair access at both ends (30" wide, 27" under table top, and 19" knee plus 5" toe clearances). See Page 31.
- **Snow Load Rated Table:** Model WAT-8, available only with recycled plastic, includes additional steel braces under the seats and top to provide a Snow Load Rating of 500 lbs. per sq. foot. This table can be used at high elevations. Model WAT-8 is also wheelchair accessible at both ends providing ADA compliant knee and toe clearances. See Pages 31, 32.
- **Optional:** Subframe support structure on Model AT and WAT-8 tables can be fabricated from steel and powder coated in your choice of colors. See Page 47 for colors.



(Top) **Model AT-6TP** 6 ft., pressure treated pine lumber.  
(Right) **Model AT/W-6PN/E1** 6 ft. seats, 8 ft. top extended 1 ft. at both ends for two wheelchair access points, recycled plastic brown leg posts, green top/seat planks.



**SNOW LOAD RATED TABLE**  
See Page 32.

**Model WAT/W-8PW** 8 ft. seats and top, wheelchair access at both ends, brown recycled plastic.

## Enjoy the Outdoors — with a complete set of site furnishings.



## “Caterpillar” Table — T600 Series

- The elevated, open span frame design of our **Model T600** Park Table creates a clear area under and around the table for easier clean up. Portable/surface mount (bolt down) installation is standard.
- All tables are ADA compliant for wheelchair access at both ends.
- The frame legs are 2-3/8" OD (2.375" OD, 11 ga. wall, 2" ID nom.) steel pipe formed and welded into single units. Seat support brackets are 10 ga. welded steel plate. Standard finish: Hot dip galvanized.
- **Optional:** Powder coat frame finish. See Page 47 for colors.
- Top/seat materials include: 2" x 10" untreated or pressure treated pine, aluminum, thermo-plastic coated D-Type expanded steel or R-Type perforated steel or formed steel channel (6 and 8 ft. only). See Pages 47-50.



(Left) **Model T604/G-8TP** table, 4 walk-in seats, 8 ft., treated pine

**Model T603/G-8DN** surface mount table, one long seat, two short seats (total 3 seats), hot dip galvanized frame, 8 ft., thermo-plastic coated expanded steel in green color.

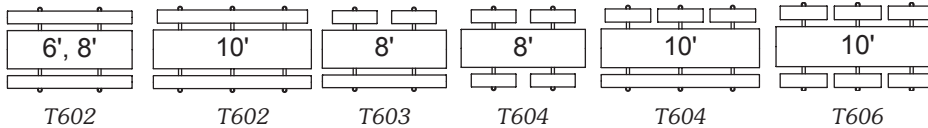

## Lighter Duty Tables — BT Series

- **Model BT** Tables combine pre-galvanized steel tube frames with the economy of a bolt together design.
- Model BT Tables feature our nontip, nontrip, walk through design. Won't tip even if all persons sit on one side. Easy walk through access. "Skid" design permits movement without damage to turf.
- Frame features: Pre-galvanized steel top/seat mounting angles, two diagonal braces of 1-5/16" OD pre-galvanized steel tube, 3/8" dia. galvanized carriage bolt fasteners.
- Tables offer 30" nom. table height; 18" nom. seat height.
- BT Table Frames come in two sizes:
  - **Model BTUG** Series is fabricated using 1-5/8" OD x 12 ga. steel tube end frames. Model BTUG tables can be 4, 6 or 8 ft. long.
  - **Model BTXG** Series is fabricated using 2-3/8" OD x 12 ga. steel tube end frames. Model BTXG tables can be 6 or 8 ft. long.
- Top/seat materials available: 2" x 10" untreated or pressure treated #1 southern yellow pine or aluminum (see Page 48). Buy complete tables or just the frame kits (fasteners included).



**Model BTUG-6UP**, 6 ft., untreated pine lumber.



(Left) **Model BTUG-4UP** 4 ft., untreated pine lumber.

(Below) **Model BTXG-8AL** 8 ft., clear anodized aluminum.



## Recycled Plastic Tables — RT Series

- **Model RT** Tables feature: 3" thick, single-piece end frames molded from 100% recycled plastic; 2" x 10" (nominal) seat/top planks molded from 100% recycled plastic. All plastic components are available in many colors. See Page 50.
- Top/seat mounting angles are formed from pre-galvanized steel. The table structure is reinforced with diagonal braces of 1-5/16" OD pre-galvanized steel tube. All 3/8" dia. galvanized carriage bolt fasteners. These steel components add strength.
- RT Tables available in 6 and 8 ft. lengths.
- Wheelchair accessible at one end: 6 ft. long seats and 8 ft. long top extended 2 ft. at one end providing the ADA recommended wheelchair clearances of 30" wide, 27" under table (ground to bottom of table top), and 24" total knee and toe clearances (19" knee + 5" toe). See Page 31.
- Model RT Tables feature our nontip, nontrip, walk through design. Won't tip even if all persons sit on one side. Easy walk through access. "Skid" design permits easier movement. Tables offer 30" nom. table height; 17-1/2" nom. seat height.



(Above) **Model RT/Y-8U**, 8 ft. yellow frames, blue top/seat planks.

(Right) **Model RT/N-6C/E** green frames, cedar colored top/seat planks, 6 ft. seats, 8 ft. top extended at one end to provide wheelchair access.



(Left) **Model RT/W-6C** 6 ft., brown frames, cedar colored top/seat planks.

*Need a matching Bench? See Page 24.  
Trash Container? See Page 54*

## Recycled Plastic Table - ART Series

- **Model ART** Tables feature: 3" thick single-piece frames with classic arch design molded from 100% recycled plastic; 2" x 6" (nom.) top/seat planks molded from 100% recycled plastic.
- Table frames can be black or brown.
- Top/seat planks are available in your choice of colors. See Page 50.
- Table design uses three step-over style frames for support so no additional steel braces are necessary. Includes stainless steel screws for assembly.
- Model ART is available in 2 standard sizes: 6 ft. and 8 ft. long.
- Wheelchair accessible at both ends: Model ART is also offered in an ADA compliant design with 6 ft. seats and 8 ft. top extended 1 ft. at each end to provide two wheelchair access points. This configuration provides the ADA recommended under table clearances of: 30" wide, 27" high, and 24" total knee and toe clearances. See Page 31. Plastic end caps are blue on table top.
- Model ART nominal dimensions: 17-1/2" seat height, 30-1/2" table top height. Non tip step over table frames, table won't tip even if all persons sit on one side.



**Model ART/B-8C**, black frames, 8 ft. long, cedar colored top and seat planks



**Model ART/W-6N/E1** brown frames, green top and seat planks, 6 ft. seats, 8 ft. top extended at both ends to provide wheelchair access at both ends.

- Web Site: [www.pilotrock.com](http://www.pilotrock.com) •
- E-Mail: [pilotrock@rjthomas.com](mailto:pilotrock@rjthomas.com) •



## Portable Square Tables — SQT Series

- **Model SQT** Tables offer portability plus a square seating pattern that fully utilizes the table top: an ideal game or craft table.

- Model SQT Tables come in two sizes:

**SQT-3** has 38" sq. top

**SQT-4** has 48" sq. top.

Each table includes 4 flat bench seats. The frame design includes our nontip, nontrip, walk-through features. Tables offer 30" nom. table height; 18" nom. seat height.

- Corner frames are fabricated from 1-1/2" OD x 1/8" wall structural steel pipe; 1-3/4" x 1-3/4" x 1/8" thick steel top/seat mounting angles; 1-5/16" OD cross braces.

- Standard frame finish: Hot dip galvanized after fabrication. Optional frame finish: Powder coating in choice of colors. See Page 47.

- Top/seat materials available: 2" x 10" untreated or pressure treated #1 southern yellow pine, 100% recycled plastic, aluminum, thermo-plastic coated expanded steel or perforated steel (thermo-plastic coated steel available on SQT-4 only). See Pages 47-50.

- **Wheelchair Accessible:** Model **SQT-4** is available with one seat structure eliminated and the top extended to create a wheelchair space that meets ADA guidelines. This table variation is available with lumber or 100% recycled plastic planks, thermo-plastic coated expanded or perforated steel.

- **Optional:** Umbrella hole/cup/collar to accommodate your choice of umbrellas with 1-1/2" diameter poles. See Page 45. (This hardware is included on thermo-plastic coated tables.)

- **Optional:** Backrest attachments for the seats, available in all the same materials to match the seats/tops. See Page 46.

- **Optional:** Game Board Table Top available on SQT-4 tables with thermo-plastic coated expanded or perforated steel. The Game Board insert is 14 ga. steel powder coated black. After the vinyl game decal is applied the insert is sealed with a clear coat finish. The standard game decal is a red/black checkerboard.

- **Optional:** 45" long contour bench seats are available on SQT-4 tables with thermo-plastic coated expanded or perforated steel. Replace the standard flat seat with 4 contour benches. (Model SQT-4).

(Above)

**Model SQT/G-4VN** galvanized frames, 48" sq. top, green thermo-plastic coated expanded steel top and seats, optional umbrella.

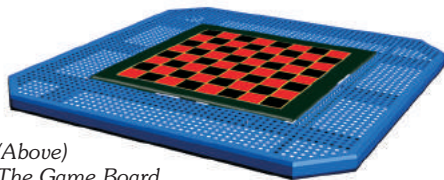

(Above) The Game Board Top option is available on 48" square tables with thermo-plastic coated steel top and seats.

(Right) Replace standard flat benches with contour seating. Available on SQT-4 tables using thermo-plastic coated expanded or perforated steel. Shown: **Model SQT/G-4VA**



**Model SQT/G-3PC** galvanized frames, 38" sq. top, 100% recycled plastic in cedar color.



**Model SQT3/G-4PA/E** galvanized frames, 48" sq. top, 100% recycled plastic in gray color, one seat eliminated and top extended to provide wheelchair access.



**Model PQT/G-4AL** embedded post, galvanized frames, 48" top, clear anodized aluminum.



**Model PQT3/P/G-4PY**  
one seat removed for wheelchair access, showing optional bolt down base plate installation, galvanized frames, 48" top, yellow 100% recycled plastic.

(Right) The Game Board Top option is available on 48" square tables with thermo-plastic coated steel top and seats.

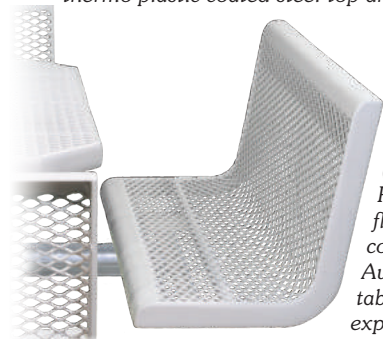

(Left)  
Replace standard flat benches with contour seating. Available on PQT-4 tables using thermo-plastic coated expanded or perforated steel.

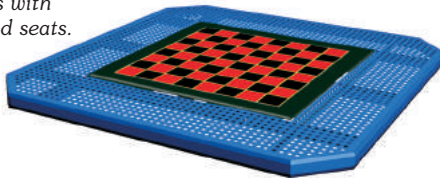

**Model PQT/P/CB-3UP** showing optional bolt down base plate installation, black powder coat frames, 38" top, untreated pine lumber.

## Square Pedestal Table — PQT Series

- **Model PQT** Pedestal Tables provide a secure, permanent location with the advantages of the square shape.
- Model PQT Tables come in two sizes:
  - **PQT-3** has 38" sq. top
  - **PQT-4** has 48" sq. top.
 Each table includes 4 flat bench seats. 32" table height, 20" seat height (nominal dimensions).
- Table is supported by one central, massive 5-3/8" sq. steel post. Embedded installation is standard. Each seat is supported by a 3-1/2" diameter steel tube, designed to resist lateral torsion and deflection. Single, central support post simplifies maintenance around table.
- Stationary installation prevents theft. Assembly points all fasteners to inside of central post so carriage bolt nuts are not exposed. Installation of top prevents access to inside of post.
- Standard frame finish: Hot dip galvanized after fabrication. Optional frame finish: Powder coating in choice of colors. See Page 47.
- Top/seat materials available: 2" x 10" untreated or pressure treated #1 southern yellow pine, 100% recycled plastic, aluminum, thermo-plastic coated expanded or perforated steel (thermo-plastic coated steel available on PQT-4 only). See Pages 47-50.
- **Wheelchair Accessible:** Model **PQT-4** with 48" sq. top is easily adapted to provide wheelchair access. By removing one or more arm/seat structures the side of the table becomes accessible.
- **Optional:** Frame post provided with 3/8" x 16" sq. steel bolt down base plate (anchor bolts not included). See Pages 46 and 113.
- **Optional:** Umbrella hole/cup/collar to accommodate your choice of umbrellas with 1-1/2" diameter poles. See Page 45. (This hardware is included on thermo-plastic coated tables.)

- **Optional:** Game Board Table Top available on PQT-4 tables with thermo-plastic coated expanded or perforated steel. The Game Board insert is 14 ga. steel powder coated black. After the vinyl game decal is applied the insert is sealed with a clear coat finish. The standard game decal is a red/black checkerboard.
- **Optional:** 45" long contour bench seating is available on PQT-4 tables with thermo-plastic coated expanded or perforated steel. Replace the standard flat seat with 4 contour benches (Model PQT-4).

## Two Installation Methods

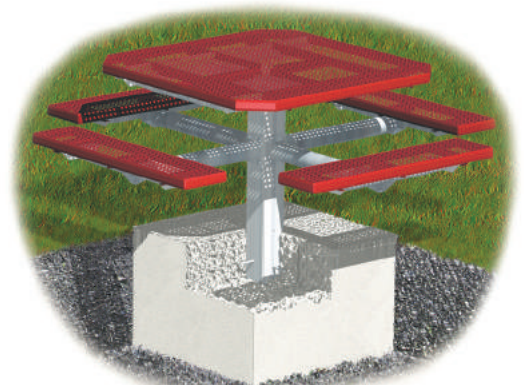

**Model PQT/G-4HR** showing standard embedded post installation, galvanized frames, 48" top, red thermo-plastic coated perforated steel.

- Web Site: [www.pilotrock.com](http://www.pilotrock.com) •
- E-Mail: [pilotrock@rjthomas.com](mailto:pilotrock@rjthomas.com) •



**Model T104/CB-4RR** portable table, black powder coated frames, 48" dia. round top, four curved seats, perforated steel coated with red thermo-plastic.

## Round Tables

- A perfect fit for... malls, patios, pools, decks, restaurants, rec centers, common areas, schools, golf courses, hotels, streetscapes, ...any casual place where people gather.
- 48" diameter (nom.) round top with four seats.
- Frame finish: Hot dip galvanized or powder coated. See Page 47.
- Top and seat material choices:
  - Thermo-plastic coated D-type expanded steel
  - Thermo-plastic coated R-type perforated steel
  - Thermo-plastic coated cut steel plate.
  - 100% recycled plastic top and seats.
 See Page 49-50 for colors.
- Umbrella hole in top and receiving cup on frame. Umbrella is optional. See Page 45.

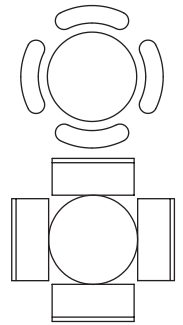

### ◀ T100 Series Portable Table

- Four flat curved seats, 10" x 40" (nom.), enough seating for up to eight people, with two frame legs supporting each seat.
- 1-1/2" dia. welded steel pipe frame.
- **Optional:** Four contour bench seats. See Page 41.

### T200 Series Portable Table ▶

- Four seats with one frame support under each seat. A choice of 16" dia. (nom.) round seats to accommodate four people, or 10" x 40" (nom.) curved seats to accommodate up to eight people, or four chairs. See Page 41.
- 2-3/8" dia. steel pipe frame members bolt to a center hub.

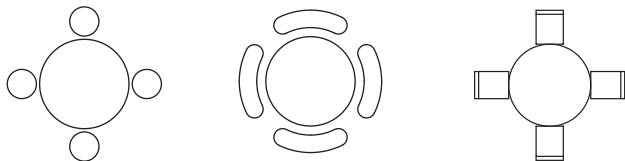

**Model T214/G-4PC** portable table, galvanized frames, 48" dia. round top, 4 round seats, with 100% recycled plastic in cedar color.



**Model T304/G-4DU** stationary table (embedded post), galvanized frames, 48" dia. round top, 4 curved seats, expanded steel coated with blue thermo-plastic.

### ◀ T300 Series Embedded Post T400 Series Surface Mount

- Central support post is 5-3/8" sq. steel tube; seat support arms are 3-1/2" OD steel tube.
- Four 10" x 40" (nom.) flat curved seats provide seating for up to eight people, or four contour bench seats. See Page 41.
- Two choices of permanent theft-proof installation: Surface mount base plate or embedded post in concrete footing.
- Make the table wheelchair accessible by omitting one or more seats.

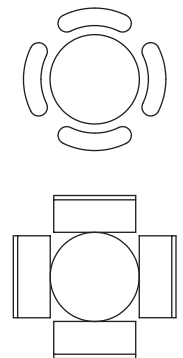





## Game Board Table Top

- Play your favorite game on this checkerboard style Game Board Table Top.
- Game Board is available on round tables with thermo-plastic coated expanded or perforated steel tops.
- Game Board insert is fabricated from 14 ga. steel, powder coated black. Includes automotive quality clear coat finish over red/black vinyl game decal and steel insert.

**Model T204/G-4DW/GT** portable table, hot dip galvanized frames, 48" dia. round top, four flat curved seats, expanded steel with brown thermo-plastic coating, optional game board top.

## Chair Seat Available on T200 Series

- Replace the flat curved or round seats on the T200 round table with individual chairs.
- The 16" wide chair is fabricated using 3/4-#9 expanded steel or 14 ga. perforated steel, with 1/4" thick side plates and 14 ga. and 7 ga. steel reinforcing with thermo-plastic coating to match the table top.



**Model T224/G-4DW** portable table, galvanized frames, 48" diameter round top, 4 chair seats, expanded steel coated with brown thermo-plastic.



## Bench Seat on T100, T300 and T400 Series

- Replace the flat curved seats on the T100, T300 or T400 round tables with contoured bench seats with room for two.
- The 45" wide seat is fabricated using 3/4-#9 expanded steel or 14 ga. perforated steel, with 1/4" thick side plates and 14 ga. and 7 ga. steel reinforcing.
- Each bench will be thermo-plastic coated to match the table top. See Page 49 for color choices.

**Model T134/CB-4DA**, portable table, black powder coat frames, 48" diameter round top, 4 contour expanded steel bench seats, coated with gray thermo-plastic.

## Cut Steel Plate Top and Seats

- Available on all T Series Round Tables.
- 10 ga. cut steel plate makes an attractive top/seat design and a durable table structure.
- Thermo-plastic coat finish on top/seats. See Page 50 for color choices.
- Curved flat seats available on all models. Round seat available on T200 only.
- Wheelchair accessible tables are available using the T300 or T400 frames.



**Model T204/G-4SP/TU** portable table, galvanized frames, 48" diameter round top, 4 curved flat seats, cut steel thermo-plastic coated blue.

**Model T104/G-4PC** portable table, galvanized frames, 48" dia. round top, four curved flat seats, 100% recycled plastic in cedar color.



## 100% Recycled Plastic Top and Seats

- Curved flat seats: 10" x 40" (nom.) on T100, T300 and T400.
- Round seats: 16" dia. (nom.) on T200.
- 100% recycled and recyclable plastic components, 2" thick. See Page 50 for colors.
- 2-piece top for easier handling and assembly. Includes umbrella hole.
- Wheelchair accessible tables are available using T300 or T400 frames.

## Multi-Pedestal Table — APT Series

- **Model APT** Multi-Pedestal Rectangular Tables provide a secure, permanent location. Stationary installation prevents theft. Table can be 6 or 8 ft. long with two full-length bench seats. 30" table height, 18" seat height (nominal dimensions).
- Provides a permanent location using two heavy pedestal posts of 3" x 6" x 1/8" wall rectangular steel tubing to support the table top and each seat. Exposed ends of frame posts are sealed with welded on end caps.
- Standard frame finish: Hot dip galvanized after fabrication. Optional frame finish: Powder coating available in choice of colors. See Page 47.
- Top/seat materials available: 2" x 10" untreated or pressure treated #1 southern yellow pine, 100% recycled plastic planks or timbers (see below), aluminum, thermo-plastic coated expanded steel or perforated steel or formed steel channel. See Pages 47-50.
- **Wheelchair Accessible:** Table may be provided with 8 ft. top, extending 1 ft. at each end beyond 6 ft. long seats to provide two wheelchair access points in accordance with ADA guidelines. See Page 31.
- **Optional:** All frame posts provided with 1/4" x 8" sq. steel bolt down base plate (anchor bolts not included). See Pages 46 and 113.



**Model APT/G-6UP** embedded post installation, galvanized frames, 6 ft., untreated pine.



**Model APT/P/G-8VW** optional bolt down base plate installation, galvanized frames, 8 ft. long, thermo-plastic coated expanded steel in brown.



**SNOW LOAD RATED TABLE**  
When equipped with V-Type expanded steel, or H-Type perforated steel top/seats. See Page 32.

*New!*



**Model APT/CN-6PA34**, surface mount installation, green powder coated frames, 6 ft. long, 3" x 4" gray recycled plastic top and seats.



Outside timbers have a rounded profile. There is no square edge. This makes the seats and top more comfortable to use.

## New Material on APT Tables.

### New Style. New Look. Same Frame.

- APT multi-pedestal picnic tables are available with 3 x 4" (nom.) top and seat timbers in 100% recycled plastic. See Page 50 for colors.
- The outside timbers on both seats and the top have a rounded profile. There is no square edge.
- The steel frame components have the same features as described above.
- This table can be 6 or 8 ft. long. A wheelchair accessible design is also available (see description above).



**Model APT/CB-6PC34/E1** embedded post installation, black powder coated frames, 3" x 4" cedar colored recycled plastic 8 ft. top and 6 ft. seats, wheelchair accessible on both ends.

## Twin Pedestal Table — TPT Series

- **Model TPT** Twin Pedestal Tables provide a secure, permanent location, with twin steel support posts. The table can be 6 ft. or 8 ft. long (two pedestals) and 10 ft. long (three pedestals). Each table has two full-length bench seats. 31 inch table height, 18 inch seat height (nominal dimensions).
- Twin support posts are 4" x 1/8" wall sq. steel tube. Seat support arms are 2-1/2" x 3/16" wall sq. steel tube. Step over entry. Stationary installation prevents theft.
- Embedded post installation is standard.
- Frame finish: Hot dip galvanized or powder coated See Page 47.
- Top/seat materials available: 2" x 10" (nom.) untreated or pressure treated #1 southern yellow pine, 100% recycled plastic planks (6 and 8 ft. lengths only), aluminum, thermo-plastic coated D-Type expanded steel or R-Type perforated steel, formed steel channel (6 and 8 ft.). See Pages 47-50.
- **Wheelchair accessible:** 8 ft. top extends 2 ft. beyond 6 ft. seats at one end provides ADA compliant wheelchair access. See Page 31.
- **Optional:** Twin frame posts provided with 3/8" x 10" sq. steel bolt down base plate (anchor bolts not included) for surface installation. See Pages 46 and 113.

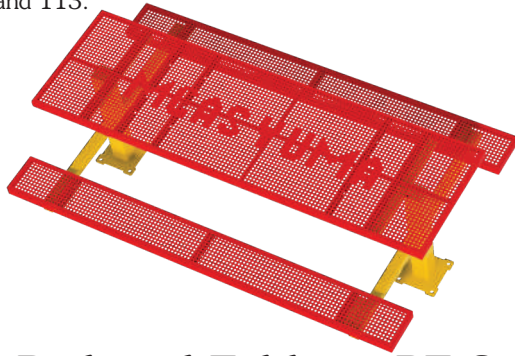

(Left) **Model TPT/P/CY-8RR** twin pedestal table, surface mount base plate, yellow powder coated frames, 8 ft., red thermo-plastic coated perforated steel top and seats. Shown with optional custom lettering. See Page 25.



(Above) **Model TPT/P/G-6UP** twin pedestal table, surface mount base plate, hot dip galvanized frames, 6 ft., untreated pine top and seats.

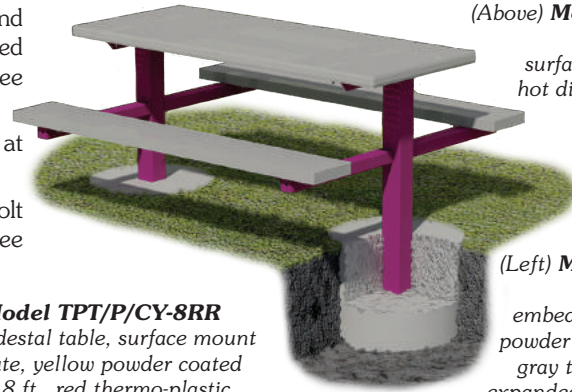

(Left) **Model TPT/CE-6DA** twin pedestal table, embedded posts, burgundy powder coated frames, 6 ft., gray thermo-plastic coated expanded steel top and seats.

## Single Pedestal Table — PT Series

- **Model PT** Pedestal Rectangular Tables provide a secure, permanent location. Table is 6 ft. long with two full-length bench seats. 32" table height, 21" seat height (nominal dimensions).
- Supported by one central, massive 5-3/8" sq. steel post. Embedded installation is standard. Seat support arms are 3-1/2" dia. steel tube, designed to resist lateral torsion and deflection. Single, central support post simplifies maintenance around table.
- Stationary installation prevents theft. Assembly points all fasteners to inside of central post so carriage bolt nuts are not exposed. Installation of top prevents access to inside of post.
- Frame finish: Hot dip galvanized or powder coated. See Page 47.
- Top/seat materials available: 2" x 10" untreated or pressure treated #1 southern yellow pine, 100% recycled plastic planks, aluminum, thermo-plastic coated D-Type expanded steel or R-Type perforated steel or formed steel channel. See Pages 47-50.
- PT Tables are wheelchair accessible at both ends by design.
- **Optional:** Frame post provided with 3/8" x 16" sq. steel bolt down base plate (anchor bolts not included). See Pages 46 and 113.

**Model PT/P/G-6PR** with optional bolt down base plate installation, galvanized frames, red 100% recycled plastic.



**Model PT/G-6UP** with standard embedded post (See PQT table diagram on page 39), galvanized frames, untreated pine lumber.



## Square Frame Picnic Tables and Utility Tables

- **T700 Series** tables and utility tables offer a clean cut square end frame design with inlaid top and seat planks.
- Surface mount installation only. Anchor bolts not included. See Page 113.
- All steel, welded component construction. End frames are 2" x 2" x 11 ga. square steel tube. Top/seat framework is 1" x 2" x 14 ga. rectangular steel tube, with formed steel channel reinforcements. All open ends are welded closed with steel end caps.
- All steel frame components have a powder coat finish. See Page 47.
- Top/seat inlay materials include 2" x 4" (nom.): 100% recycled plastic in choice of colors, or construction heart redwood. See Page 48, 50. All inlaid planks are installed at the factory.
- Assembly of end frames to top/seat components is required.
- See matching benches on Page 5, matching trash receptacle on Page 58.
- Wheelchair accessible: All rectangular tables provide ADA compliant wheelchair access at both ends. A square table with three seats is also ADA compliant on one side.
- Available T700 Series Table configurations include:
  - **Model T700-6:** rectangular utility table, no seats, 6 ft.
  - **Model T700-8:** rectangular utility table, no seats, 8 ft.
  - **Model T702-6:** rectangular picnic table, 2 bench seats, 6 ft., wheelchair accessible.
  - **Model T702-8:** rectangular picnic table, 2 bench seats, 8 ft. wheelchair accessible.
  - **Model TQ700-4:** square utility table, no seats, 4 ft.
  - **Model TQ703-4:** square picnic table, 3 bench seats, 4 ft., wheelchair accessible.
  - **Model TQ704-4:** square picnic table, 4 bench seats, 4 ft.



**Model T702/CB-8PA** Picnic Table, black powder coat frames, 8 ft. long, 2" x 4" 100% recycled plastic planks in gray color. ADA compliant wheelchair access at both ends of table.



**Model T700/CB-8PA** Utility Table, black powder coat frames, 8 ft. long, 2" x 4" 100% recycled plastic planks in gray color.

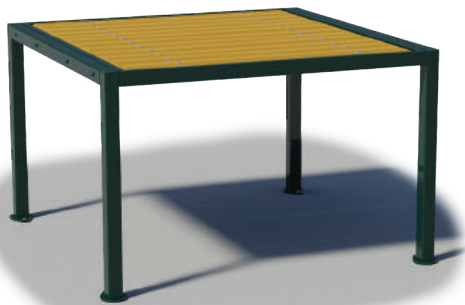

**Model TQ700/CN-4PC** Square Utility Table, green powder coat frames, 4 ft. sq. top, 2" x 4" 100% recycled plastic planks in cedar color.



**Model TQ704/CE-4PU** Square Picnic Table, burgundy powder coat frames, 4 ft. sq. top, 2" x 4" 100% recycled plastic planks in blue color.

Table Model	Style	Length	Bench Seats	ADA Compliant Access	Top/Seat Inlay Material	Frame Finish
T700-6	Utility Table	6' Rectangular	None	Yes - All Sides	100% recycled plastic 2" x 4" (nom.) planks in cedar color (PC) is standard. Other colors available. See Page 50. Optional materials: Construction Heart Redwood (CO) 2" x 4" (nom.) planks.	Powder coat black finish (CB) is standard. Other colors available. See Page 47.
T700-8	Utility Table	8' Rectangular	None	Yes - All Sides		
T702-6	Picnic Table	6' Rectangular	(2) 6'	Yes - Both Ends		
T702-8	Picnic Table	8' Rectangular	(2) 8'	Yes - Both Ends		
TQ700-4	Utility Table	4' Square	None	Yes - Any Side		
TQ703-4	Picnic Table	4' Square	(3) 4'	Yes - One Side		
TQ704-4	Picnic Table	4' Square	(4) 4'	No		

# UMBRELLAS

## Shade for Square and Round Picnic Tables



### Model UM-10 Premium Acrylic Fabric Market Style Umbrella

- 9 ft. diameter, market style.
- Eight 1-1/8" x 3/4" thick Indonesian hardwood ribs. Brass fittings and rivets. Heavy resin runner. Draft vent.
- 1-1/2" Indonesian hardwood pole, two sections.
- Rope and heavy gauge pulley lift. No tilt.
- Premium acrylic fabric, 9 oz. marine grade, solution dyed, UV resistance. Available in solid colors only.
- **Solid Colors:** pacific blue, forest green, navy blue, toast, and white.

### Model UM-4 Premium Acrylic Fabric Umbrella

- 7-1/2 ft. diameter, garden style.
- Eight chrome plated steel ribs and stretchers. Steel bell cap. Non-twisting end tips.
- 1-1/2" OD anodized aluminum pole.
- Crank lift with steel cable, and EZ-Latch spring mechanism. Stainless steel double joints and rivets make opening and closing easy. No draft vent.
- 3-position tilt, heavy gauge mechanism, nylon runner.
- Premium acrylic fabric, 9 oz. marine grade, solution dyed, UV resistance. Available in solid and alternating colors:
- **Solid Colors:** pacific blue, forest green, sunflower yellow, logo red.
- **Alternating colors:** pacific blue/white, forest green/white, logo red/white, and beach ball (red, yellow, blue, bright green).
- Manual lift option available by special order.



### Model UM-5 Economy Vinyl Umbrella

- 7-1/2 ft. diameter, garden style.
- Eight chrome plated steel ribs. Steel bell cap. Non-twisting end tips.
- 1-1/2" OD anodized aluminum pole.
- Crank lift with steel cable, and EZ-Latch spring mechanism. Stainless steel double joints and rivets make opening and closing easy. No draft vent.
- 3-position, heavy gauge tilt mechanism, nylon runner.
- Heavy gauge 13 oz. vinyl material available in solid or alternating colors:
- **Solid colors:** white, forest green, blue, red, navy, kelly green, yellow.
- **Alternating colors:** forest green/white, kelly green/white, blue/white, red/white, navy/white, yellow/white.
- Manual lift option available by special order.

## Heat Shield for Picnic Table Tops

- **Model HS-TB/G** Heat Shield protects your picnic table top from the damage caused by the heat off small gas grills, charcoal grills, skillets, or Dutch Ovens that picnickers often bring with them.
- Protects wood, plastic and coated steel table tops from heat damage caused by hot cooking utensils.
- Designed for easy installation on most brands of tables, most styles of tops. Includes fastener package for 2" x 10" lumber or plastic, and expanded or perforated steel tops.
- Expanded steel surface with steel frame. No assembly required. Approximately 12" deep x 25-1/2" wide x 3-1/2" tall. Hot dip galvanized finish for maximum protection.



## Table Top End Cap — Reduces Warping

- Install picnic table top end caps to prevent warping on new lumber, or to correct minor warpage on old lumber. Keep all top planks in alignment so your table remains usable.
- Use these formed pregalvanized steel channels to align the planks at both ends of your picnic table top. Especially useful on tables with lumber tops extended to provide wheelchair access.
- Table Alignment Kit includes (2) formed 28" long pregalvanized steel channels and wood screws (install from bottom up).
- Order Part Number TAK-21G for 2" nominal dim. lumber (2" x 4", 2" x 6", 2" x 8", 2" x 10").
- Order Part Number TAK-31G for 3" x 10" nom. dim. lumber.



## Enjoy the Outdoors

with a Pilot Rock Grill next to your Picnic Table— the perfect table accessory.



## Surface Mount Base Plate

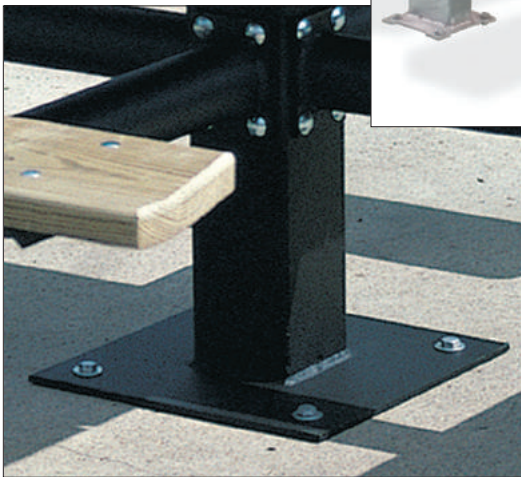

- Optional bolt down base plate installations are available on Model PQT Square Tables, Model PT, APT, and TPT Rectangular Tables, and T400 Round Tables.
- The standard post is replaced by a shortened post with a welded on steel plate to be bolted to an existing surface. Anchor bolts are not included with this option. See Page 113.
- Model PQT, PT, and T400 Tables are equipped with a 3/8" x 15-3/4" square steel base plate. Model APT Table posts have a 1/4" x 8" sq. steel base plate. Model TPT posts include a 3/8" x 10" square plate. All have (4) 25/32" dia. anchor holes.

## Backrests



(Above) Backrest on 6 ft. rectangular table.

(This option is not available on UTK and SQTK tables.)

(Below) Backrest on 48" square table.

- Optional Backrests are available on 6 and 8 ft. long UT, XT Rectangular Tables and SQT Series Square Tables. This option can be added to new or existing tables.
- Die-formed steel backrest bracket is sandwiched between seat plank and table frame for a secure, bolted installation.
- Backrest planks are available in lumber on rectangular tables; all materials on SQT tables.



**Picnic Table Mover —  
Now one person can move heavy tables!**

- A commercial quality tool for relocating tables for a special event or for seasonal storage.
- The TM-500 works independently of the frame style because it attaches to the seat plank. It will work on most table designs regardless of brand: rectangular tables up to 12 ft. long; tables with steel frames or molded plastic frames; A-frames and walk-through (skid-type) frames; tables with wood, aluminum, plastic, or thermo-plastic coated steel tops and seats. (Does not work on split seat tables such as side access and Model T600.)
- The design can accommodate many seat plank widths and thicknesses (max. 3" x 12-1/2").
- Allows one person to move heavy tables. Does not require use of motorized vehicles or licensed operators.



**U.S. Pat. No. 6,955,367**

*Model TM-500 Table Mover shown with Model WXTH/G-8PB Universal Accessible Table*



*Attach*



*Lift*



*Lock and Roll*

- Tables can be moved over most firm ground surfaces, low curbs, and into or out of remote areas not accessible to vehicles.
- Pneumatic tires provide a wide, stable platform to carry the table weight (up to 500 pounds) so the operator just pushes, pulls and steers. Minimal lifting is required so there is less chance of injury.
- The simple design uses few moving pieces or loose parts.
- Hot dip galvanized finish is maintenance free. The Seat Hook is thermo-plastic coated to protect the seat plank surface.

**MATERIALS & COLORS**

**Powder Coat Finish**

Selected Pilot Rock bench and table components (steel and aluminum), lantern holders, trash receptacle holders, and bike racks are available with baked on lead-free TGIC polyester powder coat finish that is applied in a multi-step process of material preparation and finish application. This process includes: detailed chemical cleaning; application of a corrosion inhibiting phosphate-free high pressure, high temperature bath; rinse; seal rinse; high temperature dry time; electrostatic application of the powder coat paint; chemical bonding to metal substrate in 430 degree industrial oven. The tough 3 mil thick coating offers a superior finish to liquid paints.

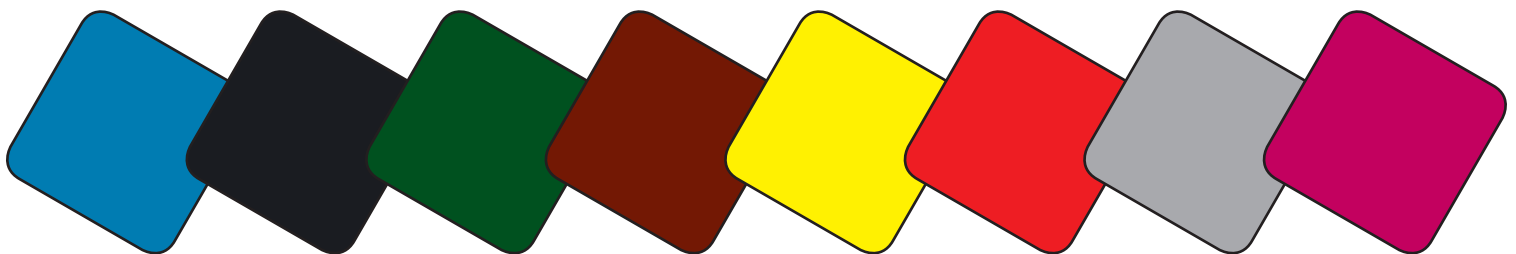

**Blue**  
(CU) for steel  
(AU) for aluminum

**Black**  
(CB) for steel  
(AB) for aluminum

**Green**  
(CN) for steel  
(AN) for aluminum

**Brown**  
(CW) for steel  
(AW) for aluminum

**Yellow**  
(CY) for steel  
(AY) for aluminum

**Red**  
(CR) for steel  
(AR) for aluminum

**Gray**  
(CA) for steel  
(AA) for aluminum

**Burgundy**  
(CE) for steel  
(AE) for aluminum

**Model No. Example for Powder Coat Finish products:** XT/◆-6UP Replace (◆) with letters indicating color choice listed under sample.

NOTE: Custom colors may be available when ordered in sufficient quantity and additional lead times.

# MATERIALS & COLORS

## Heat Resistant Black Enamel Paint

Pilot Rock grills and campfire rings are finished with a high heat resistant, non-toxic, matte (low gloss) black enamel paint. This silicone-based paint is lead and chrome free and formulated especially for Pilot Rock. It is capable of enduring temperatures exceeding 750 degrees.

## Untreated #1 Southern Yellow Pine

Untreated #1 grade Southern Yellow Pine planks, kiln dried to reduce moisture content. The lumber is ready for you to water seal, paint or stain. All lumber is precision drilled to facilitate assembly. All exposed edges are removed to 3/8" radius. Use "UP" in model number for untreated pine. Tables use 2" x 10" planks. All dimensions are nominal.

## Treated #1 Southern Yellow Pine

Treated (wolmanized) #1 grade Southern Yellow Pine is pressure treated and kiln dried after treatment (KDAT) to reduce moisture content. Wood preservative (no arsenic) gives superior protection against termites, insects and decay. The lumber is clean to handle, dry and ready for you to water seal, paint or stain. All lumber is precision drilled to facilitate assembly. All exposed edges are removed to 3/8" radius. Use "TP" in model number for treated pine. Tables use 2" x 10" planks. Benches can use 2" x 4" or 2" x 10" planks (varies by model). Trash receptacles use 2" x 4" slats. All dimensions are nominal.



## Construction Heart Redwood

Construction heart redwood is a popular alternative to pine. Select planks are made from the interior grain of American Redwood. Redwood naturally resists decay. It is available in several common lumber dimensions. All lumber is precision drilled to facilitate assembly. All exposed edges are removed to a 3/8" radius. This grade allows for knots up to 2-1/2" dia. Use "CO" in model number for construction heart redwood.



## Exotic Imported Hardwoods

Exotic imported hardwoods exhibit high resistance to decay, water damage and physical damage without the use of chemical treatments. Their features often imitate redwood. All of these hardwoods are imported from managed forests. Currently available only as 3" x 4" (nominal) timber for Pilot Rock benches. Species may vary depending on availability and cost. Please inquire. Currently using an Indonesian Balau wood (as of 10-2004), use "IB" in model number.



**Other species of lumber:** cedar, fir and clear redwood may be available when in stock. Please inquire.

**Note:** Colors and textures may vary. Colors shown are as close to the actual colors as the printing process is able to reproduce them.

## Hot Dip Galvanized Finish

Selected Pilot Rock bench and table frame components, lantern holders, trash receptacle holder components, bike racks and two grills are available with a hot-dip galvanized finish that is applied after fabrication and welding to ASTM-A123 specifications to maintain an average zinc coating of 2.0 oz. per sq. ft. of surface area. Use "/G" in model number for hot dip galvanized finish, e.g. XT/G-6UP.

## Aluminum

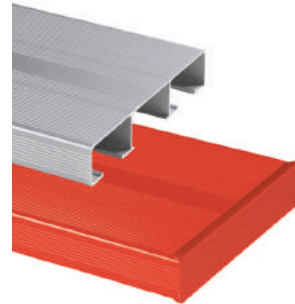

Several select picnic tables and benches can be equipped with seats/top or seat/back of aluminum planks. These planks are extruded 6063-T6 aluminum, equivalent in size to 2" x 10" (nominal) lumber planks. Four structural ribs provide rigid support and strength. The aluminum is clear anodized to specification 204 R1 for a clean, maintenance free finish. All plank ends are covered by an extruded, clear anodized aluminum end cap fastened

into place. Table tops are made into single units (at the factory) by connecting the planks with one-piece end caps fastened across each end of the top. Aluminum planks are provided with precision fitted aluminum brackets and galvanized carriage bolts to attach planks to table or bench frames. Use "AL" in model number for clear anodized aluminum, e.g. XT/G-6AL.

**Optional:** Aluminum components (max. 12 ft. length) are also available with powder coated mill finish aluminum planks. See Powder Coat Finish description for details.

## Coated Steel Channel Components for Benches and Tables. Looks like 2x4 lumber. Has the strength of steel.



- Formed steel channel (SC) components approximate 2" x 4" lumber dimensions, but are formed using 16 ga. steel plate with 16 ga. bracing. These tops and seats are strong and light weight.
- Formed steel channels (SC), steel end caps and understructure bracing are pre-assembled at the factory. So onsite assembly is easier.
- After assembly each component is thermoplastic coated (/T). See the color chart below. Use "/T♦" in model number to specify color choice.

Black (TB)	Green (TN)	Gray (TA)
Brown (TW)	Red (TR)	Blue (TU)
Replace (♦) in model number with letter indicating color choice		



## Thermo-Plastic Coated Expanded Steel and Perforated Steel and Formed Steel Products

Selected Pilot Rock bench, table and trash receptacle products and components (expanded steel, perforated steel, cut/formed steel) are finished with a thermo-plastic coating in your choice of available colors. **The thermo-plastic coating is PVC free and phthalate free.**

The UV-stabilized thermo-plastic coating is applied in a multi-step process of material preparation and finish application, designed and formulated to create superior adhesion. After cleaning, the steel component is heated to 550-600 degrees (depending on the component). It is then lowered into an air-fluidized bed of colored polyethylene powder. This fluid powder fuses and bonds to the heated metal. The component is then baked at high temperature to cure the application.

This complete process of cleaning-heating-fusing-baking tightly bonds the powder to the metal, creating a durable, colorfast finish. The thermo-plastic finish includes a superior level of UV protection, does not support mold or mildew growth, and is impact resistant. We use a textured matte finish polyethylene. These finishes are less susceptible to marring and scratching (which is often a problem with gloss finishes).

Expanded steel, perforated steel, and formed steel components are assembled and reinforced with formed steel edge bands, angle irons and bars as appropriate to each product design. All components are single piece welded construction.



Our thermocoat product has been tested by an independent lab, and given the highest rating of **DNI - Does Not Ignite** and does not support combustion during or after flame exposure.

### Two types of Expanded Steel component designs

All of the **D-Type** and **V-Type** expanded steel that we use is 3/4"-#9 material with a short longitudinal stretch. A shorter stretch means smaller "diamond" openings, which leaves more material (steel) per foot. The more diamonds there are per lineal foot is your indication that there is more steel left in the structure. Therefore, the top and seats will be stronger. It is also called the "long way design, non flattened expanded metal". "Non flattened" means the steel is "on edge" around the diamonds. This provides a stronger, more rigid material.

**D-Type:** This standard duty table top/seat and other component design is built for your most common public use applications.

**V-Type: SNOW LOAD/EXTREME LOAD RATED.** This design incorporates wider edge banding and more structural supports to create a table built for applications and locations that can be more abusive to the structure. This material is especially suited for high elevation areas where winter snow load can destroy average tables. The V-Type Snow Load/Extreme Load design is available on WXT, WXTH, WPTS, XT, XTH, APT, and APTX series tables. See Page 32. \*See note below.

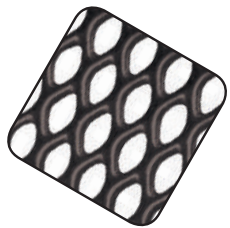

**Black**  
Use **DB** or **VB**  
in model no.

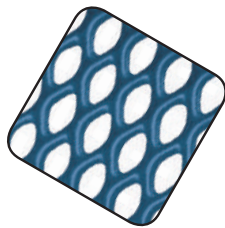

**Blue**  
Use **DU** or **VU**  
in model no.

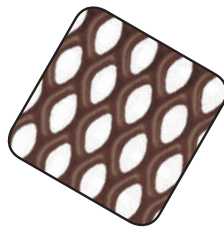

**Brown**  
Use **DW** or **VW**  
in model no.

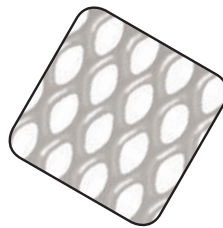

**Gray**  
Use **DA** or **VA**  
in model no.

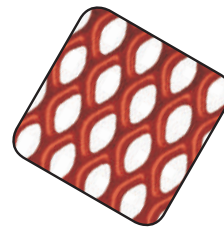

**Red**  
Use **DR** or **VR**  
in model no.

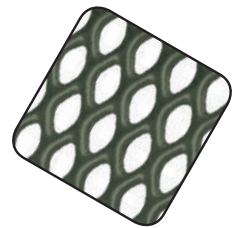

**Green**  
Use **DN** or **VN**  
in model no.

**Example: Model XT/G-8DB is equipped with standard duty top/seat structures for regular applications.**

**Example: Model XT/G-8VB is equipped with the snow load rated top/seat structures for more extreme applications.**

### Two types of Perforated Steel component designs

All of the **R-Type** and **H-Type** perforated steel is 14 ga. with 9/16" diameter holes punched on 13/16" straight line centers.

**R-Type:** This standard duty table top/seat and other component design is built for your most common public use applications.

**H-Type: SNOW LOAD/EXTREME LOAD RATED.** This design incorporates wider edge banding and more structural supports to create a table built for applications and locations that can be more abusive to the structure. This material is especially suited for high elevation areas where winter snow load can destroy average tables. The H-Type Snow Load/Extreme Load design is available on WXT, WXTH, WPTS, XT, XTH, APT, and APTX series tables. See Page 32. \*See note below.

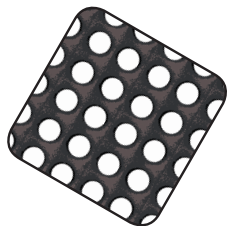

**Black**  
Use **RB** or **HB**  
in model no.

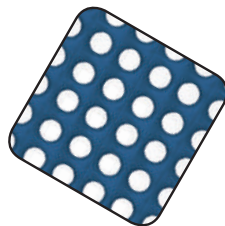

**Blue**  
Use **RU** or **HU**  
in model no.



**Brown**  
Use **RW** or **HW**  
in model no.

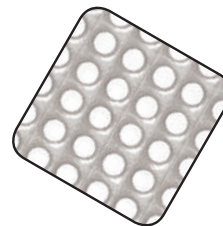

**Gray**  
Use **RA** or **HA**  
in model no.

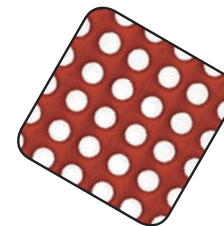

**Red**  
Use **RR** or **HR**  
in model no.

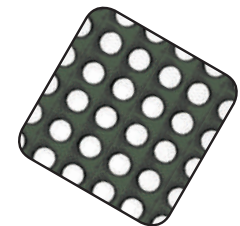

**Green**  
Use **RN** or **HN**  
in model no.

**Example for Expanded and Perforated Steel products: XT/G-8♦** Replace (♦) with letters indicating type and color listed under sample.

\*NOTE: V-Type and H-Type components are used on some benches and square tables. These applications have not been tested or rated for extreme loads.







# MATERIALS & COLORS

## Thermoplastic Coated Steel Strap, Cut Steel Plate and Formed Steel Channel Components

Several steel components (besides expanded and perforated steel) can also be finished with a thermoplastic coating. See Page 49 for a process description. These different steel component designs have different Model Number designators. Then a “/T” plus the color letter is added for the thermoplastic finish. See Chart:

Steel Material	Thermo-plastic coated steel material is currently available on these products:
Formed Steel Channel (SC)	Most rectangular picnic tables (6' & 8'); CXB, AB, APB, and WMB Benches (6' & 8')
Steel Strap (SS)	CN-R/SS3-36 trash receptacle; CN-R/SS3-ASH ash receptacle; P-23 Planter
Cut Steel Plate (SP)	B70 and B120 benches; T Series round tables, CN-R/SP2-32 trash receptacle
Other Steel Products	BR20 bike rack; HRP and HRE bike racks; T-246 flat steel lid; CN-EXP52 park policeman

Replace (♦) in model number with letter indicating color choice						
	Black (TB)	Green (TN)	Gray (TA)	Brown (TW)	Red (TR)	Blue (TU)

## 100% Recycled Plastic Timbers, Planks, and Frames

Our recycled plastic material is 100% recycled high-density polyethylene and is formed using a combination of post-consumer and post-industrial waste plastics. There is no virgin plastic in this product. Post-consumer plastic has been used by a consumer and then recycled to avoid dumping in a landfill (such as milk jugs). Post-industrial plastics have gone through a manufacturing process but never reached the consumer (such as product rejects or process wastes). On average our product is 80% post consumer and 20% post industrial (percentages can vary). Our plastic components are 100% recycled and can also be

recycled again and again. There are no toxic chemicals in this product. Plastic by its very nature does not leach.

A solid color is formed throughout the component and a UV stabilizer is added for ultraviolet protection. This recycled plastic is a dense, durable product, offering a long lasting, attractive appearance. It will not splinter or rot, and is resistant to mold and insects. These components are molded into solid dimensional shapes corresponding to nominal lumber dimensions. Recycled plastic components are available in your choice of colors.



**Model No. Example for Recycled Plastic products: PCXB/G-4♦24** Replace (♦) with letters indicating color choice listed under sample.

Note: Custom colors and textures may be available when ordered in sufficient quantity and additional production lead times.

## Graffiti Removal Suggestions

Our recycled plastic lumber is extremely chemical resistant to very harsh chemical removers.

There are several graffiti removal tools on the market that could be used on our plastic lumber. Harsh graffiti removers like MEK, NexGen, and Gasoline solutions will not harm the plastic lumber. Be sure to wash off any residue.

Pressure washing, with detergent added, will remove most dirt, grime, markings, and debris. When pressure washing, start with the tip far away, and then gradually move closer to the plastic lumber to avoid gouging the plastic lumber with too aggressive of a pressure wash.

If the substance is ground in, oily or sticky; some type of solution will be needed to loosen up the stain to get it out of the textured surface of the plastic lumber.

**Note:** Colors and textures may vary. Colors shown are as close to the actual colors as the printing process is able to reproduce them. When selecting colors, keep in mind that Thermo-plastic Coating for tables and seats and Powder Coating for frames may not be exactly the same color -- i.e., Blue Thermo-plastic Coating for seats and/or table tops and Blue Powder Coating for frames may differ slightly.



## Tilting Trash Receptacle

Collection basket is suspended off the ground for easier grounds area maintenance and unloading.

Features include:

- Perforated steel basket has approximate 52 gallon capacity. Use your disposable garbage bags inside. No separate liner required.
- Support yoke is single piece 2-3/8" OD steel pipe. Twin pedestal support can withstand public exposure. The basket is suspended about 13" off the ground surface for convenient access for the public and maintenance crew.
- No heavy vertical lifting! Basket weight is supported by the yoke. Just tip it forward and remove the trash bag. The 60-degree tilt makes it easy to slide the trash bag out.
- Durable, commercial grade spring-loaded pin holds the basket in the vertical collection position and in the tilted unloading position. Easy one person operation.
- The solid band around basket provides a visible area for custom signage - cut into the basket or use adhesive vinyl decals.
- The yoke framework is powder coated. The perforated basket is thermo-plastic coated. Matching colors are standard. For color choices see Pages 47 and 49.
- **Standard:** Embedded post installation – **Model CN-TR-52.**
- **Optional:** Surface mount bolt down base plate – **Model CN-TR/P-52** (includes two sets #ANC1-4 concrete anchor bolts).
- **Optional:** Band-It trash bag loop to hold your trash bag in the basket. See Page 64.
- **Optional:** Your choice of plastic or steel trash or recycling lids. See Pages 60-64.

**Model CN-TR/CR-52RR** Tilting Trash Receptacle, red powder coat frame finish and red thermo-plastic coat basket finish. Shown with optional **Model CN-SDR/B-24** black plastic dome lid. Illustrated with standard embedded post installation.



The solid band around the entire basket provides a visible area for your custom signage. See Page 25 and 64.



**Model CN-TR/P/CY-52RR** Tilting Trash Receptacle, yellow powder coat frame finish and red thermo-plastic coat basket finish, with optional bolt down base plate installation, with optional **Model CN/Y-4455** yellow plastic dome lid. Shown with optional custom lettering in basket.



**Model CN-TR/CN-52RN** Tilting Trash Receptacle, green powder coat frame finish and green thermo-plastic coat basket finish, shown with optional **Model CN-PD/N-24** green plastic dome lid. Shown in locked vertical position for collecting trash. Provide your own disposable trash bag liner.



**Model CN-TR/P/CN-52RN** Tilting Trash Receptacle, green powder coat frame finish and green thermo-plastic coat basket finish, with optional bolt down base plate installation, shown with lid removed and locked at 60 degree tilt position for easy trash bag removal.

- Web Site: [www.pilotrock.com](http://www.pilotrock.com) •
- E-Mail: [pilotrock@rjthomas.com](mailto:pilotrock@rjthomas.com) •



## ◀ Round Receptacle — Vertical Steel Straps

- **Model CN-R/SS2-36** trash receptacle is designed to hold most available 30 to 36 gallon liners.
- Fabricated using 1/8" thick x 2" wide steel vertical ribs. The top flares out to include a 1" diameter steel tube ring. The base structure includes a steel flange ring and cross braces with holes to provide anchor points for surface mounting. (Anchor bolts not included.) All components are welded into a single unit. No assembly required.
- Four threaded adjustable levelers located equally around the base ring allow for installation on uneven surfaces.
- Powder coat finish in your choice of colors. See Page 47.
- **Optional:** Steel or rigid plastic liners. See Page 65.
- **Optional:** Trash and recycling lids. See Pages 60-64.
- **Optional:** Stationary mounts are available. See Page 66. For surface anchors see Page 113.

(Left) **Model CN-R/SS2/CU-36** receptacle, blue powder coat finish, shown with optional **Model T/CU-2410R** steel lid with rain cover, and **Model CN/B-1827** plastic liner.



**Model CN-R/SS2/CE-36** receptacle, burgundy color with optional **Model CN-SDR/B-24** plastic dome lid and **Model CN/B-1827** plastic liner.

## Round Receptacle — Cut Steel Plate ▶

- **Model CN-R/SP2-32** will hold most 30-36 gallon liners.
- Formed using a single piece of 10 ga. cut steel plate.
- The base includes steel cross braces to reinforce the receptacle and to keep the liner inside up off the ground. Holes in these cross braces provide anchor points for surface mounting (anchor bolts not included).
- Colorful thermo-plastic coat finish. See Page 50.
- **Optional:** Stationary mounts. See Page 66.
- **Optional:** Steel or rigid plastic liners. See Page 65.
- **Optional:** Plastic or steel lids. See Pages 60-64.



**Model CN-R/SP2/TA-32** cut steel plate receptacle, thermo-plastic coated gray, optional **Model CN-PD/U-24PC5** plastic dome recycling lid (right), or optional **Model T/CB-2410** flat lid (above), optional **Model M2/G** embedded stationary mount, and **Model CN/B-1827** liner.



## ◀ Round Receptacle — Perforated Steel

- **Model CN-R/R-32** trash receptacle (23-1/4" OD x 29-3/4" tall) will hold most 30-36 gallon liners.
- Fabricated from a single piece of 14 ga. perforated steel (round holes) and reinforced with 10 ga. top and bottom rings and die-formed cross braces across the bottom providing holes for surface anchoring options. All welded construction, no assembly required.
- Complete unit is coated with UV-stabilized thermo-plastic. See Page 49.
- **Optional:** Galvanized steel or rigid plastic liners. See Page 65.
- **Optional:** Trash and Recycling Lids. See Pages 60-64.
- **Optional:** Stationary mounts. See Page 66. For surface anchors see Page 113.
- **Optional:** Model CN-R/R-52 Receptacle (not shown) has 52 gallon capacity (26-1/2" OD x 29-3/4" tall).
- **Optional:** Model CN-R/R-55 Receptacle (not shown) has 55 gallon capacity (26-1/2" OD x 36" tall).



**Model CN-R/RU-32** Round Perforated Steel Trash Receptacle Holder for 32 gal. containers, blue thermo-plastic coated. Shown with optional **Model CN-SDR/U-24** blue plastic dome lid.

**Model CN-R/RW-32** Round Perforated Steel Trash Receptacle Holder for 32 gal. containers, brown thermo-plastic coated. Shown with optional **Model CN-PD/W-24** brown plastic dome lid.



## ◀ Round Receptacle — Expanded Steel

- **Model CN-R/D-32** trash receptacle (23-1/4" OD x 29-3/4" tall) will hold most 30-36 gallon liners..
- Fabricated from a single piece of 3/4-#9 expanded steel (diamond holes) and reinforced with 10 ga. top and bottom rings and die-formed cross braces across the bottom providing holes for surface anchoring options. All welded construction, no assembly required.
- Complete unit is coated with UV-stabilized thermo-plastic. See Page 49.
- **Optional:** Galvanized steel or rigid plastic liners. See Page 65.
- **Optional:** Trash and Recycling Lids. See Pages 60-64.
- **Optional:** Stationary mounts are available. See Page 66. For surface anchors see Page 113.
- **Optional:** Model CN-R/D-52 Receptacle has 52 gallon capacity (26-1/2" OD x 29-3/4" tall).
- **Optional:** Model CN-R/D-55 Receptacle (not shown) has 55 gallon capacity (26-1/2" OD x 36" tall).

**Model CN-R/DW-32** Round Expanded Steel Trash Receptacle Holder for 32 gal. containers, brown thermo-plastic coated. Shown with optional **Model CN-PD/N-24PC1** green plastic dome recycling lid, and optional **Model M2/G** embedded mount pedestal base.



**Model CN-R/DN-52** receptacle, optional **Model CN-PD/N-27** plastic dome lid, optional **M7/G** surface pedestal mount.

## Square Receptacle — Expanded Steel ▶

- **Model CN-Q/D-32/2** will hold most 30-36 gallon liners..
- This container is formed using 4 flat expanded steel side panels, a base reinforced with cross braces, and a canopy top with large openings for easy trash disposal. Each piece is thermo-plastic coated. See Page 50 for colors. This unit is shipped knocked down to reduce freight costs. Galvanized fasteners included.
- The bottom panel keeps the liner off the ground. Anchor holes in cross braces can be used to secure receptacle in place (anchor bolts not included).
- **Optional:** Stationary mounts are available. See Page 66. For surface anchors see Page 113.
- **Optional:** Galvanized steel cans or rigid plastic liners are available. See Page 65.



**Model CN-Q/DR-32/2** receptacle, expanded steel, red thermo-plastic coating. Shown with optional **Model CNG-2310C** galvanized steel trash can.



## ◀ Park Policeman

- **Model CN-EXP52** offers a large 48-gallon capacity. The tapered body is 23-1/2" diameter at the top and 19-1/2" diameter at the bottom. It is 33" tall and weighs 31 pounds.
- This heavy-duty waste receptacle is fabricated using expanded metal mesh for the body, with rolled top and bottom edging for added strength, safety and easy handling. Six vertical ribs and two horizontal rings reinforce the whole structure. The hot dip galvanized finish is standard.
- **Optional:** Trash and recycling lids. See Pages 60-64.
- **Optional:** Thermo-plastic coat finish. See Page 50.
- **Optional:** Seasonal ground anchors. See Page 66.

**Model CN/G-EXP52** Receptacle and optional **Model CN/G-5555** lid.



**Model CN/TN-EXP52** Receptacle with green thermo-plastic coating and optional **Model T/CN-2410A** steel ash lid.



## Trash and Recycling Receptacles — TRH Series

• **Model TRH** Trash Receptacle Holders are an attractive way to collect trash or recyclables while disguising and protecting the liner inside.

• **Model TRH** Trash Receptacle Holders are available in three sizes:

• **Model TRH-20** (20-3/8" ID) holds a 20- or 24-gallon capacity can or liner.

• **Model TRH-32** (22-3/8" ID) holds a 30- to 36-gallon capacity can or liner.

• **Model TRH-55** (25-3/8" ID) holds a 55-gallon barrel or liner.

• **Standard:** 2" x 4" (nom.) slat material: pressure treated #1 southern yellow pine.

• **Optional:** 100% recycled plastic slats. See Page 50. Construction heart redwood lumber may be available when in stock. Please inquire.

• Coordinate the receptacle size, slat color, lid and lid color to your landscape and collection needs.

• TRH frames include a top and bottom ring; both rolled using 10 ga. steel with a formed flange for strength. The base ring is reinforced with die-formed cross braces. These braces also serve to keep the container inside the TRH up off the ground. Each ring is hot dip galvanized after fabrication. Galvanized fasteners included.

• **Optional:** Steel or rigid plastic liners. See Page 65.

• **Optional:** Trash and recycling lids. See Page 60-64.

• **Optional:** Stationary mounts. See Page 66. For surface anchors See Page 113.

• **Optional:** Powder coat finish on frame rings. See Page 47.

• **Optional:** Custom engraving on recycled plastic slats.



### Planters

Colorful planters coordinate with trash containers. See Page 83.



(Left) **Model TRH/G-32PA24** receptacle with **Model CN/N-3031PS** paper recycling lid.



(Top Right) **Model TRH/G-32PN24** receptacle with **Model CN-PD/Y-27** lid, on **Model M3/G** surface pedestal mount.

(Right) **Model TRH/G-55TP24** receptacle with **Model CN-PD/W-27** lid.

(Below) **Model TRH/G-32TP24** receptacle with **T/CN-2410A** ash lid.



## Side Opening Trash Kit

• **Model TRH-55/SO** receptacle includes a side opening to deposit trash into a 30-32 gallon liner. Kit includes: Model TG-27X flat lid, a hinge/hasp kit to attach the lid to top frame ring, one brass padlock to secure lid, and a 30-32 gallon plastic trash can, galvanized finish on steel components.

• Slats available in treated pine or 100% recycled plastic in a choice of colors. See Page 50.

• **Optional:** Powder coat finish on frames and lid in choice of colors. See Page 47.



**Model TRH-20**, holds most 20- or 24-gal. cans, 20-3/8" ID, 25" tall.

**Model TRH-32**, holds most 30- to 36-gal. liners, 22-3/8" ID, 30" tall.

**Model TRH-55**, holds most 55-gal. barrels, 25-3/8" ID, 36" tall.



## Square Receptacle — TRQ Series

- **Model TRQ** Trash Receptacle comes in a Square shape for a different look. Model TRQ-32 receptacles hold 30 to 36-gallon capacity liners.
- Coordinate the receptacle slat color, lid and lid color to your landscape and collection needs.
- Standard 2" x 4" (nom.) slat material: pressure treated #1 southern yellow pine. **Optional:** 100% recycled plastic slats. See Page 50. Construction heart redwood lumber may be available when in stock. Please inquire.



(Above)  
**Model TRQ/G-32TP24**  
receptacle, treated pine  
slats, with optional  
**Model CN-PQD/B-27** lid.

(Left)  
**Model TRQ/G-32TP24**  
receptacle, treated pine  
slats, with optional  
**Model TQ/CW-2410A**  
ash lid.



(Above) **Model TRQ/G-32PA24**  
receptacle, gray colored plastic slats,  
with optional **Model CN-PQD/N-27** lid.

(Right) **Model TRQ/G-32PW24**  
receptacle, brown plastic slats,  
with optional **Model CN/B-1826** lid.

- TRQ frames include a top and bottom ring, fabricated using 10 ga. steel with a formed flange for strength. The base ring is reinforced with die-formed cross braces. These braces also serve to keep the container inside the TRQ up off the ground. Each ring is hot dip galvanized after fabrication. Galvanized fasteners are included.
- **Optional:** Steel or rigid plastic liners. See Page 65.
- **Optional:** Trash and recycling lids. See Page 60-64.
- **Optional:** Stationary mounts. See Page 66. For surface anchors see Page 113.
- **Optional:** Powder coat finish on frame rings. See Page 47.
- **Optional:** Custom engraving on recycled plastic slats. See Page 25.



## Ash Receptacles — Round TRH & Square TRQ Series

**Model TRH/G-ASH/TP24**  
round ash receptacle  
with treated #1 southern  
yellow pine slats. Shown next  
to **Model TRH/G-32TP24**  
trash receptacle holder.



- Ash Receptacles match in style and design the TRH round and TRQ square trash and recycling receptacles. Coordinate both smoking waste and trash collection with matched receptacles.
- Rugged construction for outdoor use – welded steel frame rings with hot dip galvanized finish.
- Slats are 2" x 4" (nom.) treated pine or 100% recycled plastic. See Page 50.
- Ash Receptacle can stand alone, be bolted to the surface, or be mounted in place with optional posts. See Page 66, 113.
- Large capacity aluminum sand bowl is cabled to receptacle – it can be removed for cleaning but not stolen.
- Deep sand bowl protects sand from the wind.
- Includes an 8 lb. bag of sand.



**Model TRQ/G-ASH/PW24** square ash  
receptacle with brown 100% recycled  
plastic slats. Shown on **Model M11/G**  
surface pedestal mount.



## Amherst Receptacles — Steel Receptacles for collecting trash and recyclables.

- The **Amherst Series** receptacles feature all steel, all welded construction.
- The vertical and horizontal straps are fabricated from 10 ga. steel. Three horizontal bands and the integral steel tube around the top provide more reinforcement than found on most similar receptacles. Powder coated finish. See Page 47. The receptacles are shipped fully assembled. Includes #CK-5 lid cable kit.
- The steel bottom braces include holes for surface anchors (not included). Optional elevated mounting posts (Models M7/G and M8/G) are available to secure the receptacles in place. See Page 66. All Amherst trash receptacles include four levelers.
- Two shapes: the traditional Round shape is **Model CN-AMR**. The contemporary Square shape is **Model CN-AMQ**. Both will hold up to a 36-gallon capacity liner (optional).



**Model CN-AMQ/CB-32** square steel receptacle, black powder coated finish. Shown with optional **Model CN-PQD/A-24** gray square plastic dome lid.



**Model CN-AMQ/CN-32** square steel receptacle, green powder coated finish. Shown with optional **Model TQ/CN-2410R** steel lid with rain cover. Shown with optional signage.



**Model CN-AMR/CW-32** round steel receptacle, brown powder coated finish. Shown with optional **Model CN-PD/N-24** green plastic dome lid.



**Model CN-AMR/CN-32** round steel receptacle, green powder coated finish. Shown with optional **Model T/CN-2410R** steel lid with rain cover.

- The Amherst design keeps the optional lid inside and below the top of the flare to keep wind and weather from dislodging it. Both receptacles have multiple lid choices. See Pages 60-64.
- **Optional:** Steel or rigid plastic liners. See Page 65.
- **Optional:** Steel bands around AMR and AMQ provide an area for your custom vinyl decal signage. See Page 64.

## Ash Receptacles — Round AMR and Square AMQ Series

- Ash Receptacles match in style and design the Amherst AMR round and AMQ square trash receptacles. Coordinate both smoking waste and trash collection with matched receptacles.
- Rugged construction for outdoor use – all steel welded fabrication mirrors the specifications of the full-size Amherst trash receptacles.
- Powder coat finish (see Page 47 for colors).
- Ash Receptacle can stand alone, be bolted to the surface, or be mounted in place with optional posts (see Page 66, 113).
- Large capacity aluminum sand bowl is cabled to receptacle – it can be removed for cleaning but not stolen.
- Deep sand bowl helps protect sand from the wind.
- Includes 8 lb. bag of sand.



**Model CN-AMR/CW-ASH** round ash receptacle, brown powder coat finish.



**Model CN-AMQ/CB-ASH** square ash receptacle, black powder coat finish.



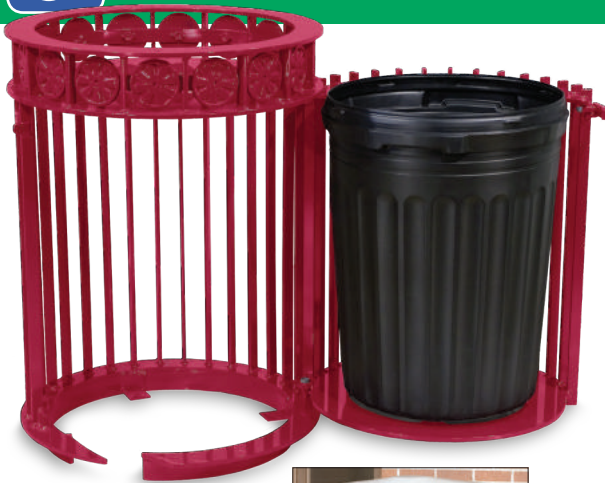

(Top and Left) **Model CN-OKR/CE-36** with burgundy powder coat finish.  
(Right) **Model CN-OKR-C/CA-36** with integral Rain Cover and gray powder coat finish.

## Oak Knoll Trash Receptacle — With Swing Open Door and Platform

- With **Model CN-OKR** as you open the side door the inside liner rolls out – carried on its own platform and supported by a rugged commercial caster underneath.
- **Fabrication:** All steel, all welded construction, including: 3/8" x 1" vertical steel ribs, a 3/8" steel top plate with a 10" diameter hole for depositing trash. A ring of decorative cast iron rosettes frames the top opening.
- The top is integrated into the complete construction.
- **Liner:** Heavy duty, 36 gallon, rigid plastic liner is included.
- **Operation:** Side door easily rolls open on a caster and carries the trash liner with it. Push the door closed and it self latches. A padlock is included for security.
- **Finish:** Powder coat paint finish in choice of colors. See Page 47.
- **Installation:** Includes (4) 3/8" x 3" concrete screw surface anchors (#ANC3-4).
- Two styles to choose from:
- **Model CN-OKR** does not include a rain cover.
- **Model CN-OKR-C** includes a welded-on steel rain cover.
- **Optional:** For matching planter see Page 83.
- **Optional:** Coordinate with Oak Knoll bench. See Page 21.



The 10 inch dia. top opening makes it easy to deposit even large trash items.

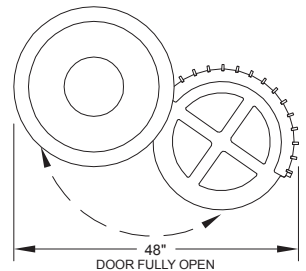

The side door easily rolls open and carries the trash liner with it - completely out of the receptacle - for easy access.

## Steel Strap Receptacle with Door

- **Model CN-R/SS2-36D** steel strap receptacle includes a side open door for easy access to remove and empty the liner inside.
- Fabricated using 1/8" thick x 2" wide steel vertical ribs. The flare top is reinforced with a 1" dia. steel tube ring. The base structure includes a steel flange ring and cross braces. These braces include holes for surface anchor points (anchors not included) or pedestal mounts. All components are welded into a single unit. No assembly required.
- Includes threaded adjustable levelers located equally around the base ring for installation on uneven surfaces.
- Base ring supports liner 2" off the ground for longer useful life.
- Powder coat finish in your choice of colors. See Page 47.
- **Optional:** Steel or rigid plastic liners. See Page 65.
- **Optional:** Trash or recycling lids. See Pages 60–64.
- **Optional:** Stationary mounts (M2 or M3). See Page 66.
- **Optional:** ANC2-4 set of (4) 3/8" x 5" concrete surface screw anchors.

*New!*



**Model CN-R/SS2/CB-36D** round steel strap receptacle with door, finished in black powder coat. Shown with **Model CN-PD/A-24** gray plastic dome lid and **M3/G** pedestal mount.



Same receptacle with door open. Shown with **Model T/CB-2410** flat steel lid with black powder coat finish and **CN/B-1827** rigid plastic liner.



## Square Steel Frame & Inlay Receptacle

*New!*

- **Model CN-Q-36** square frame receptacle with inlaid slats is the perfect site complement for the B130 Series Benches (page 5) and the T700 Series Picnic Tables (page 44). This square receptacle completes the ensemble. It also looks great on its own.
- Fabricated using 2" x 2" x 11 ga. square steel tube and steel channel for the four side panel frames. Each side frame is a welded single unit. Each corner post includes an anchor plate to secure the receptacle on site if desired (anchor bolts not included).
- All steel frame components have a powder coat finish in your color choice. See Page 47.
- Side panel inlay materials include: 100% recycled plastic in choice of colors, or construction heart redwood. See Pages 48, 50. All inlaid planks are installed at the factory.
- Assembly of four side panels to each other is required on site.
- **Optional:** Steel or rigid plastic liners. See Pages 65.
- **Optional:** Plastic or steel square lids. See Pages 60–64.
- **Optional:** #ANC3-4 set of (4) 3/8" x 3" concrete surface screw anchors. See Page 113.



**Model CN-Q/CB-36PA** Square Frame Receptacle with black powder coated frame and gray recycled plastic slats. Shown with **Model CN-PQD/A-24** plastic dome lid.

(Below)

**Model CN-Q/CR-36PC**, red powder coated frame, cedar colored recycled plastic slats, with **Model T/CR-2410** square flat lid with red powder coat finish.



*New!*

## Square Steel Strap Receptacle with Door

- **Model CN-Q/SS4-36D** square steel strap receptacle includes a side open door for easy access to remove and empty the liner inside. And it offers the alternate square receptacle shape.
- Fabricated using 1/8" thick x 2" wide steel vertical ribs. The flare top is reinforced with a 1" dia. steel tube ring. The base structure includes a steel flange ring and cross braces. These braces include holes for surface anchor points (anchors not included) or pedestal mounts. All components are welded into a single unit. No assembly required.
- Includes threaded adjustable levelers located equally around the base for installation on uneven surfaces.
- Base ring supports liner 2" off the ground for longer useful life.
- Powder coat finish in your choice of colors. See Page 47.
- **Optional:** Steel or rigid plastic liners. See Page 65.
- **Optional:** Plastic or steel square lids. See Pages 60–64.
- **Optional:** Stationary mounts (M2 or M3). See Page 66.
- **Optional:** ANC2-4 set of (4) 3/8" x 5" concrete surface screw anchors. See Page 113.
- For matching benches see Pages 19-21.

(Above)  
**Model CN-Q/SS4/CY-36D** receptacle with yellow powder coat finish, door open. Shown with **Model T/CY-2410** flat steel lid and **CN/B-1827** rigid plastic liner.  
(Left) Same receptacle with door closed. Shown with **Model CN-PQD/Y-24** plastic dome lid.





## Round Receptacle – Vertical Wave Steel Strap

- **Model CN-R/SS3-36** trash receptacle is designed to hold most available 30-36 gallon liners. Dimensions: 32" tall x 29" OD x 22-3/4" ID.
- Fabricated using 1/8" thick x 1" wide steel vertical ribs with a die formed wave pattern. The top is finished and reinforced with a steel tube ring of 1" OD x 14 ga. wall steel tube. The base structure includes a 10 ga. steel ring and cross braces with holes to provide anchor points for surface mounting (anchor bolts are not included). All components are welded into a single unit. No assembly required.
- Four threaded adjustable levelers located equally around the base ring allow for installation on uneven surfaces.
- Thermo plastic coat finish in your choice of colors. See Page 50.
- **Optional:** Steel or rigid plastic liners. See Page 65.
- **Optional:** Trash or recycling lids. See Page 60-64.
- **Optional:** Anchor kit #ANC3-4 (four 3/8" x 3" concrete screw anchors) for hard surface mounting. See Page 113.
- **Optional:** Matching Ash Receptacle (see below) and Planter (see Page 83).

*Model CN-R/SS3/TN-36 receptacle, green thermo-plastic coat finish, shown with optional Model T/CN-2410 flat steel lid with green powder coat finish, and optional CN/B-1827 liner.*



## Ash Receptacle – Vertical Wave Steel Straps

- **Model CN-R/SS3-ASH** ash receptacle is designed to match in style and design the CN-R/SS3-36 Trash Receptacle (see above). Dimensions: 29" tall x 20" OD.
- Rugged steel construction for outdoor use – all steel welded fabrication mirrors the specifications of the full size trash receptacle. No assembly required.
- Thermo plastic coat finish in your choice of colors. See Page 50.
- Ash Receptacle can stand alone, be bolted to the surface or be mounted in place with optional posts. See Page 66 and 113.
- Large capacity aluminum sand bowl is cabled to receptacle – it can be removed for cleaning but not stolen.
- Deep sand bowl helps protect sand from wind.
- Includes 8 lb. bag of sand.

*Model CN-R/SS3/TN-ASH round ash receptacle, green thermo plastic coat finish.*



## Smoker's Stack

- All steel construction – won't melt or burn.
- Remove cigarette and cigar waste from view. Convenient size opening accepts all kinds of tobacco waste, but restricts deposit of other trash.
- Heavy gauge all steel construction will resist vandalism. Can be used in remote park and trail locations and in any public setting. Stands 40" tall. Includes decal identification.
- Two piece set includes: Square outer mounting post with bolt down base plate (concrete anchor bolts included); Round inner collection tube which lifts out to empty waste. A recessed set screw locks collection tube inside post and deters vandals. Requires allen wrench (included) to remove.
- Powder coated finish. See Page 47 for colors.

*(Left) Model SS/P/CY-1 Smoker's Stack, base plate install, powder coated yellow.  
(Right) shows removal of inner Collection Tube.*





## Round Pilot Rock Plastic Dome Lids



Round

- Self-closing, weighted hatch
- Eight colors available

Model No.	I.D.	O.D.	Use with these Receptacle Holders
<b>CN-PD/◆-27</b>	27-1/4"	27-3/4"	TRH-32, TRH-55 (fits on top ring), CN-R/R-52, CN-R/D-52, CN-R/R-55, CN-R/D-55
<b>CN-PD/◆-24</b>	24"	24-1/2"	TRH-32, TRH-55 (fits on barrel inside), CN-AMR-32, CN-R/R-32, CN-R/D-32, CN-R/SS2-36, CN-R/SS2-36D, CN-EXP52, CN-R/SP2-32, CN-TR-52, CN-R/SS3-36, RA's

Cedar (C)	Brown (W)	Yellow (Y)	Green (N)	Gray (A)	Black (B)	Red (R)	Blue (U)
Replace (◆) in model number with letter indicating color choice							



Square

Model No.	I.D.	O.D.	Use with these Receptacle Holders
<b>CN-PQD/◆-27</b>	27"	27-1/2"	TRQ-32
<b>CN-PQD/◆-24</b>	23-1/2"	24"	CN-AMQ-32, TRQ-32, CN-Q-36, CN-Q/SS4-36D

## Plastic Dome Lids



Arched Door

- Self-closing, spring loaded hatch
- Six colors available

Model No.	I.D.	O.D.	Use with these Receptacle Holders
<b>CN/◆-4455</b>	24"	24-3/4"	TRH-32, TRH-55 (fits on barrel inside), CN-AMR-32, CN-R/R-32, CN-R/D-32, CN-R/SS2-36, CN-R/SS2-36D, CN-EXP52, CN-R/SP2-32, CN-TR-52, CN-R/SS3-36, RA's, 55 gal. barrel

Brown (W)	Gray (A)	Yellow (Y)	Black (B)	Red (R)	Blue (U)
Replace (◆) in model number with letter indicating color choice					

## Plastic Dome Lids



Square Door

- Self-closing hatch
- Large opening
- Eight colors available

Model No.	I.D.	O.D.	Use with these Receptacle Holders
<b>CN-SDR/◆-24</b>	24"	24-3/8"	TRH-32, TRH-55 (fits on barrel inside), CN-AMR-32, CN-R/R-32, CN-R/D-32, CN-R/SS2-36, CN-R/SS2-36D, CN-EXP52, CN-R/SP2-32, CN-TR-52, CN-R/SS3-36, RA's, 55 gal. barrel

Cedar (C)	Brown (W)	Yellow (Y)	Green (N)	Gray (A)	Black (B)	Red (R)	Blue (U)
Replace (◆) in model number with letter indicating color choice							

## Steel Dome Lids — Galvanized or Powder Coated



- Self-closing, spring loaded hatch
- Hot dip galvanized (✓G)
- Optional powder coat finish

Model No.	I.D.	O.D.	Use with these Receptacle Holders
<b>CN/◆-3434</b>	21"	21-3/4"	Federal Duty 32 Gal. Galvanized Can, CNG-WHD32C
<b>CN/◆-5555</b>	23-3/4"	24-1/2"	TRH-32, TRH-55 (fits on barrel inside), CN-AMR-32, CN-R/R-32, CN-R/D-32, CN-R/SS2-36, CN-R/SS2-36D, CN-EXP52, CN-R/SP2-32, CN-TR-52, CN-R/SS3-36, RA's, 55 gal. barrel
<b>CN/◆-2755</b>	27-1/8"	27-1/4"	TRH-55, CN-R/R-52, CN-R/D-52, CN-R/R-55, CN-R/D-55

Replace (◆) in model number with (G) for galvanized or letter indicating powder coat color choice. See Page 47 for colors



## Plastic Dome Lid for Recycling

Round Face



- Dome is molded with solid “door” panel
- Two hole sizes
- Choice of eight colors
- Includes recycling decal. See below.

Model No.	Hole Dia.	I.D.	O.D.	
CN-PD/◆-27PC1	3"	27-1/4"	27-3/4"	TRH-32, TRH-55 (fits on top ring), CN-R/R-52, CN-R/D-52, CN-R/R-55, CN-R/D-55
CN-PD/◆-27PC5	4-3/8"			
CN-PD/◆-24PC1	3"	24"	24-1/2"	TRH-32, TRH-55 (fits on barrel inside), CN-AMR-32, CN-R/R-32, CN-R/D-32, CN-R/SS2-36, CN-R/SS2-36D, CN-EXP52, CN-R/SP2-32, CN-TR-52, CN-R/SS3-36, RA's
CN-PD/◆-24PC5	4-3/8"			

Cedar (C)	Brown (W)	Yellow (Y)	Green (N)	Gray (A)	Black (B)	Red (R)	Blue (U)
Replace (◆) in model number with letter indicating color choice							

Square Face



- Dome is molded with a solid door panel
- Two hole sizes
- Eight colors available
- Includes recycling decal. See below.

Model No.	Hole Dia.	I.D.	O.D.	Use with these Receptacle Holders
CN-SDR/◆-24PC1	3"	24"	24-3/8"	TRH-32, TRH-55 (fits on barrel inside), CN-AMR-32, CN-R/R-32, CN-R/D-32, CN-R/SS2-36, CN-R/SS2-36D, CN-EXP52, CN-R/SP2-32, CN-TR-52, CN-R/SS3-36, RA's, 55 gal. barrel
CN-SDR/◆-24PC5	4-3/8"			

Cedar (C)	Brown (W)	Yellow (Y)	Green (N)	Gray (A)	Black (B)	Red (R)	Blue (U)
Replace (◆) in model number with letter indicating color choice							



CN/N-3031PC5



CN/N-3031PS

## Plastic Canopy Lid for Recycling — Collect Recyclable Cans and Paper

- Collect cans, bottles and paper for recycling.
- Single piece molded plastic lid is available in the popular green recycling color.
- Openings on both ends of the canopy.
- Twin vinyl trimmed openings are available in three sizes: 3" round, 4-3/8" round, and 2" x 7-1/2" slot.
- Includes two recycling decals. See below.

Model No.	I.D.	O.D.	Hole Dia.	Use with these Receptacle Holders
CN/N-3031PC1	24-1/8"	24-1/2"	3"	TRH-32, TRH-55 (fits on barrel inside), CN-AMR-32, CN-R/R-32, CN-R/D-32, CN-R/SS2-36, CN-R/SS2-36D, CN-EXP52, CN-R/SP2-32, CN-TR-52, CN-R/SS3-36, RA's, 55 gal. barrel
CN/N-3031PC5			4-3/8"	
CN/N-3031PS			2" x 7-1/2"	



## Recycling Decals

The plastic recycling lids shown on this page each include a “Recycle” decal. Please specify which decal you need for your collection program:

**Model DE-22** “Cans Only” (we recommend 3" dia. hole)

**Model DE-23** “Plastic Bottles Only” (we recommend 4-3/8" dia. hole)

**Model DE-24** “Cans & Bottles Only” (we recommend 4-3/8" dia. hole)

**Model DE-26** “Paper Only” (for use on CN/N-3031PS lid only)

Custom Decals are available. Same size and colors. Minimum order (15) of same design.

# WASTE & RECYCLING

## Flat Steel Trash and Recycling Lids

- Fabricated from 16 ga. galvanized steel. For standard galvanized finish replace (◆) in model number with "G".
- Optional powder coat available. For color choices see Page 47. Replace (◆) in model number with letter of desired color.
- Recycling Lid includes a vinyl-trimmed hole in choice of three sizes.
- Hinge and Hasp kits, Recycling Decals, and Lid Security Kits available. See Page 64.



### Trash Can Lids (No Hole)



Model No.	I.D.	O.D.	Use with these Receptacle Holders
T◆-19X	19"	19-1/8"	30 Gal. barrel
T◆-22X	22"	22-1/8"	TRH-20
T◆-24X	24"	24-1/8"	TRH-32, TRH-55 (fits on barrel inside), CN-AMR-32, CN-R/R-32, CN-R/D-32, CN-R/SS2-36, CN-R/SS2-36D, CN-EXP52, CN-R/SP2-32, CN-TR-52, CN-R/SS3-36, RA's, 55 gal. barrel
T◆-27X	27-1/8"	27-1/4"	TRH-55 (fits on top frame ring), CN-R/R-52, CN-R/D-52, CN-R/R-55, CN-R/D-55

### Trash Can Lid with 10" Spring-loaded Hatch



Model No.	I.D.	O.D.	Use with these Receptacle Holders
T◆-19	19"	19-1/8"	30 Gal. barrel
T◆-22	22"	22-1/8"	TRH-20
T◆-24	24"	24-1/8"	TRH-32, TRH-55 (fits on barrel inside), CN-AMR-32, CN-R/R-32, CN-R/D-32, CN-R/SS2-36, CN-R/SS2-36D, CN-EXP52, CN-R/SP2-32, CN-TR-52, CN-R/SS3-36, RA's, 55 gal. barrel
T◆-27	27-1/8"	27-1/4"	TRH-55 (fits on top frame ring), CN-R/R-52, CN-R/D-52, CN-R/R-55, CN-R/D-55

### Recycling Lid with 3" Diameter Hole

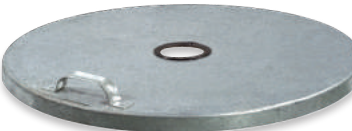

Model No.	I.D.	O.D.	Use with these Receptacle Holders
T◆-22PC1	22"	22-1/8"	TRH-20
T◆-24PC1	24"	24-1/8"	TRH-32, TRH-55 (fits on barrel inside), CN-AMR-32, CN-R/R-32, CN-R/D-32, CN-R/SS2-36, CN-R/SS2-36D, CN-EXP52, CN-R/SP2-32, CN-TR-52, CN-R/SS3-36, RA's, 55 gal. barrel
T◆-27PC1	27-1/8"	27-1/4"	TRH-55 (fits on top frame ring), CN-R/R-52, CN-R/D-52, CN-R/R-55, CN-R/D-55

### Recycling Lid with 4-3/8" Diameter Hole

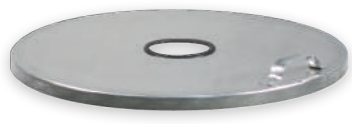

Model No.	I.D.	O.D.	Use with these Receptacle Holders
T◆-22PC5	22"	22-1/8"	TRH-20
T◆-24PC5	24"	24-1/8"	TRH-32, TRH-55 (fits on barrel inside), CN-AMR-32, CN-R/R-32, CN-R/D-32, CN-R/SS2-36, CN-R/SS2-36D, CN-EXP52, CN-R/SP2-32, CN-TR-52, CN-R/SS3-36, RA's, 55 gal. barrel
T◆-27PC5	27-1/8"	27-1/4"	TRH-55 (fits on top frame ring), CN-R/R-52, CN-R/D-52, CN-R/R-55, CN-R/D-55

### Recycling Lid with 5-7/8" Diameter Hole



Model No.	I.D.	O.D.	Use with these Receptacle Holders
T◆-22PC6	22"	22-1/8"	TRH-20
T◆-24PC6	24"	24-1/8"	TRH-32, TRH-55 (fits on barrel inside), CN-AMR-32, CN-R/R-32, CN-R/D-32, CN-R/SS2-36, CN-R/SS2-36D, CN-EXP52, CN-R/SP2-32, CN-TR-52, CN-R/SS3-36, RA's, 55 gal. barrel
T◆-27PC6	27-1/8"	27-1/4"	TRH-55 (fits on top frame ring), CN-R/R-52, CN-R/D-52, CN-R/R-55, CN-R/D-55

## Steel Lids

T/◆-2410 Flat  
T/◆-2710



T/◆-2410R  
T/◆-2710R  
12" dia. Rain Cover



T/◆-2410A  
T/◆-2710A  
6" dia. Ash Tray

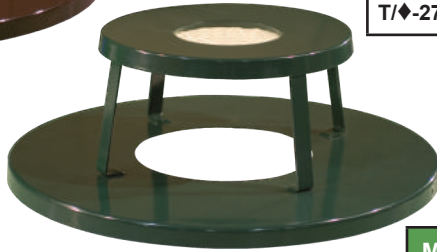

- 16 ga. formed steel construction
- 10" diameter hole
- Optional 12" diameter rain cover, add "R" to model number

- Optional 6" diameter ashtray in rain cover, add "A" to model number
- Optional: choice of powder coat colors. See Page 47. Replace (◆) in model number with letter indicating color choice.

Model No.	I.D.	O.D.	Use with these Receptacle Holders:
T/◆-2410 T/◆-2410R T/◆-2410A	24"	24-1/8"	TRH-32, TRH-55 (fits on barrel inside), CN-AMR-32, CN-R/R-32, CN-R/D-32, CN-R/SS2-36, CN-R/SS2-36D, CN-EXP52, CN-R/SP2-32, CN-TR-52, CN-R/SS3-36, RA's
T/◆-2710 T/◆-2710R T/◆-2710A	27-1/8"	27-1/4"	TRH-55 (fits on top of frame ring), CN-R/R-52, CN-R/D-52, CN-R/R-55, CN-R/D-55

Model No.	I.D.	O.D.	Use with these Receptacle Holders:
TQ/◆-2410 TQ/◆-2410R TQ/◆-2410A	23-5/8"	23-3/4"	CN-AMQ-32, TRQ-32, CN-Q-36, CN-Q/SS4-36D

TQ/◆-2410  
Flat



TQ/◆-2410R  
12" dia. Rain Cover



TQ/◆-2410A  
6" dia. Ash Tray



## Molded Plastic Lids



Round

Model No.	I.D.	O.D.	Center Hole Diameter	Use with these Receptacle Holders:
CN/B-1825	24-3/8"	25"	10"	TRH-32, TRH-55 (fits on barrel inside), CN-AMR-32, CN-R/R-32, CN-R/D-32, CN-R/SS2-36, CN-R/SS2-36D, CN-EXP52, CN-R/SP2-32, CN-TR-52, CN-R/SS3-36, RA's, 55 gal. barrel
CN/B-55FT	24"	24-3/4"	15"	

Color: Black only



Square

Model No.	I.D.	O.D.	Center Hole Diameter	Use with these Receptacle Holders:
CN/B-1826	23-3/8"	24"	10"	CN-AMQ-32, TRQ-32, CN-Q-36, CN-Q/SS4-36D

Color: Black only



Canopy

Model No.	I.D.	O.D.	Use with these Receptacle Holders:
CN/B-3030	24-1/8"	24-1/2"	TRH-32, TRH-55 (fits on barrel inside), CN-AMR-32, CN-R/R-32, CN-R/D-32, CN-R/SS2-36, CN-R/SS2-36D, CN-EXP52, CN-R/SP2-32, CN-TR-52, CN-R/SS3-36, RA's, 55 gal. barrel

Color: Black only

# WASTE & RECYCLING

## Thermo-Plastic Coated Steel Lid



T/◆-246

- 16 ga. formed steel construction.
- Choice of colors. See Page 50.
- Thermo-plastic coating includes UV inhibitors. Impact resistant.

Model No.	Hole Dia.	I.D.	O.D.	Use with these Receptacle Holders
T/◆-246	6"	24"	24-3/8"	TRH-32, TRH-55 (fits on barrel inside), CN-AMR-32, CN-R/R-32, CN-R/D-32, CN-R/SS2-36, CN-R/SS2-36D, CN-EXP52, CN-R/SP2-32, CN-TR-52, CN-R/SS3-36, RA's, 55 gal. barrel

Replace (◆) in model number with letter indicating color choice						
	Black (TB)	Green (TN)	Gray (TA)	Brown (TW)	Red (TR)	Blue (TU)

## Lid Security Kits



**CK-1 Chain Kit**  
40" x 1/8" Galvanized welded steel chain with 2 equal leg "S" hooks (Used only with RPP posts)



**CK-6 Multiple Application Chain Kit**,  
24" x 1/8" Galvanized welded steel chain with 1 eyescrew, 2 equal leg "S" hooks, and 2 unequal leg "S" hooks



**CK-5 Cable Kit**  
36" of Plastic coated 1/8" steel cable with 2 aluminum crimp sleeves



**WSK-1 Web Strap Kit**  
1" x 14" of woven nylon strap with snap hook, grommet hole, 1 D-ring and 1 "S" hook

## Hasp and Hinge Kits



**Model HHG-1:**  
Hinge/Hasp Kit to mount Model T-19 and T-24 lids to 30- or 55-gallon barrels.



**Model HHG-2:**  
Hinge/Hasp Kit to mount Model T-22, T-24, and T-27 lids to top frame ring of all TRH receptacles.

Made from galvanized steel. Zinc plated fasteners included. Optional PL-1 brass padlock through hasp prevents theft of contents and disposal of other trash. For use with Model T-19, T-22, T-24, and T-27 flat steel trash and recycling lids.



### HHG-5 Hinge Hasp Kit

- **Model HHG-5** is a unique hinge design that allows the lid to be fully opened but it remains permanently attached to the barrel. For use with our T-19 and T-24 steel lids (see Page 62) and 30- or 55-gallon barrels.
- **Features:** Galvanized finish, includes all fasteners and barrel edge spacer.
- **Optional:** Lid, barrel and #PL-1 brass padlock.

## Recycling Decals for Lids



Self-adhesive decals, 3" x 15", green letters on white vinyl background for identification of intended use for recycling units.

**Model DE-1:** "CANS ONLY"

**Model DE-2:** "PAPER ONLY"

**Model DE-3:** "PLASTIC ONLY"

**Model DE-4:** "GLASS ONLY"

**Model DE-5:** "ALUMINUM ONLY"

**Model DE-11:** "GARBAGE ONLY"

**Custom Decals Available.**

1. Same size and colors as above but with your custom message.
2. Design a custom decal specifying size, shape, color and message.
3. A minimum quantity may apply.





## Band-It Premium Elastic Trash Can Loop

- Holds plastic trash bag in place with elastic band around the top edge of the liner.
- No more mess when a plastic bag falls down inside the can. Fits metal and plastic cans from 20- to 55-gallon sizes.
- Easy to install. Reusable.
- Sold in case lots only - 36 individually packaged Band-Its per case. Order Item #**CN-BANDIT44455**.

Note: We do not sell the plastic trash bags.



	Regular Duty Galvanized Steel Cans					
	Model No.	Capacity	O.D.	Height	Weight	Use with these Receptacle Holders
	<b>CNG-WCD20C</b> without lid <b>CNG-WCD20CL</b> includes lid	20 gal.	17-1/2 in.	23 in.	7 lbs. 9 lbs.	TRH-20
<b>CNG-2310C</b> without lid. <b>CNG-2310CL</b> includes lid	31 gal.	20-1/2 in.	27 in.	10 lbs. 12 lbs.	CN-R/SS2-36, CN-R/SS2-36D, CN-R/SP2-32, CN-R/R-32, CN-R/D-32, CN-Q/D-32/2, CN-Q-36, CN-Q/SS4-36D, TRH-32, TRQ-32, TRH-55/SO, CN-AMR-32, CN-AMQ-32, CN-OKR-36, CN-R/SS3-36, RPP Post, CH-4, RA Arrays, CN-VDT-32, HCB-1	
Lighter weight, 27 ga. galvanized steel cans						

	Heavy Duty Rigid Plastic Liners					
	Model No.	Capacity	O.D.	Height	Weight	Use with these Receptacle Holders
	<b>CN/B-1827</b>	36 gal.	21 in.	28 in.	10 lbs.	CN-R/SS2-36, CN-R/SS2-36D, CN-R/SP2-32, CN-R/R-32, CN-R/D-32, CN-Q/D-32/2, CN-Q-36, CN-Q/SS4-36D, TRH-32, TRQ-32, TRH-55/SO, CN-AMR-32, CN-AMQ-32, CN-OKR-36, CN-R/SS3-36, RA Arrays, BPR Series
<b>CN/B-1828</b>	52 gal.	25 in.	29 in.	11 lbs.	CN-TR-52, CN-R/R-52, CN-R/D-52	
<b>CN/B-1829</b>	55 gal.	23-5/8 in.	35 in.	14 lbs.	CN-R/R-55, CN-R/D-55, TRH-55	





	Rigid Plastic Liners					
	Model No.	Capacity	O.D.	Height	Weight	Use with these Receptacle Holders
	<b>CN-4132C</b>	30 gal.	23 in.	27 in.	5 lbs.	CN-R/SS2-36, CN-R/SS2-36D, CN-R/SP2-32, CN-R/R-32, CN-R/D-32, CN-Q/D-32/2, CN-Q-36, CN-Q/SS4-36D, TRH-32, TRQ-32, TRH-55/SO, CN-AMR-32, CN-AMQ-32, CN-OKR-36, CN-R/SS3-36, RA Arrays, BPR Series

	Federal Duty Galvanized Steel Cans					
	Model No.	Capacity	O.D.	Height	Weight	Use with these Receptacle Holders
	<b>CNG-WHD24C</b> without lid <b>CNG-WHD24CL</b> includes lid	24 gal.	19-1/2 in.	23-1/2 in.	15 lbs. 18 lbs.	TRH-20
<b>CNG-WHD32C</b> without lid. <b>CNG-WHD32CL</b> includes lid	32 gal.	21-1/4 in.	26-1/4 in.	19 lbs. 22 lbs.	CN-R/SS2-36, CN-R/SS2-36D, CN-R/SP2-32, CN-R/R-32, CN-R/D-32, CN-Q/D-32/2, CN-Q-36, CN-Q/SS4-36D, TRH-32, TRQ-32, TRH-55/SO, CN-AMR-32, CN-AMQ-32, CN-OKR-36, CN-R/SS3-36, RPP Post, CH-4, RA Arrays, CN-VDT-32, HCB-1	
Heavy 23 ga. galvanized (ASTM A123 or A653) steel cans. Meets Fed. Spec. NSN:7240-00-160-0440 and 0441						

	55 Gallon Steel and Plastic Barrels					
	Model No.	Capacity	O.D.	Height	Weight	Use with these Receptacle Holders
	<b>CN/CB-55GB</b> Steel Barrel Powder coated black	55 gal.	23 in.	35-1/2 in.	30 lbs.	TRH-55
<b>CN-55PB</b> Plastic Barrel Color may vary	55 gal.	22-1/2 in.	37-1/4 in.	21 lbs.	TRH-55	
Dimension are approximate and may vary. Available when in stock.						

## Mounts for Trash Receptacles — Elevated

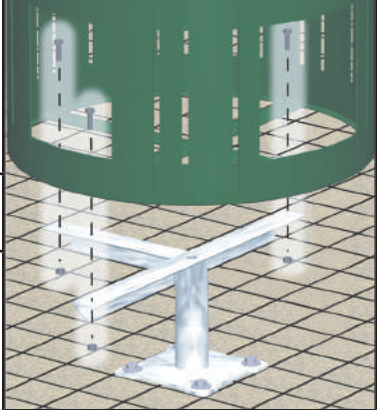
- A 2-3/8" OD steel pipe base post, welded to structural steel angle cross arms, bolts to the cross braces in the receptacle base ring (fasteners included).
- Elevated Pedestal Mounts supports receptacles 8" above ground.
- Standard hot dip galvanized finish (/G).
- Optional powder coat finish. See Page 47.

Embedded Pedestal Mount The post is embedded into a concrete footing.	Model No.	Support	Use with these Receptacle Holders	Model No.	Surface Pedestal Mount Includes a welded 1/4" x 8" x 8" base plate anchored to surface (anchor bolts not included). See Page 113.
	M2	3 Crossarms 	TRH-32, TRQ-32, CN-R/R32, CN-R/D-32, CN-Q/D-32, CN-R/SS2-36, CN-R/SS2-36D, CN-R/SP2-32, CN-R/SS3-36, CN-Q/SS4-36D	M3	
	M4		TRH-20	M5	
	M8	4 Crossarms 	TRH-55, CN-AMR, CN-AMQ, CN-R/D-52, CN-R/D-55, CN-R/R-52, CN-R/R-55	M7	

## Mounts for Trash Receptacles — Ground Level

- Seasonal Anchors for ground level installation of all TRH's and TRQ's. Four black enamel (/B) steel rods install through holes in cross braces of bottom frame ring and into ground. Allows for relocation of receptacle.

Seasonal Ground Level Mount	Model No.	Receptacle Mount	Use with these Receptacle Holders
	M6/B	Rods	TRH-20, TRH-32, TRH-55, TRH-55/SO, TRQ-32, CN-AMR, CN/AMQ, CN-EXP52, CN-Q/D-32/2, CN-R/R-32, CN-R/D-32, CN-R/SP2-32, CN-R/SS2-36, CN-R/SS3-36, CN-R/R-52, CN-R/D-52, CN-R/R-55, CN-R/D-55. Included with RA Arrays.

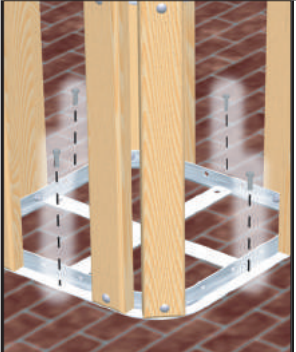
Permanent Surface Anchoring	
	TRH and TRQ receptacle base frames include (3 or 4) 9/32" dia. holes in flange to allow anchoring to a concrete surface using 1/4" x 2-1/4" concrete screws. Anchor bolts are not provided.  NOTE: use same size anchors for TRH-ASH and TRQ-ASH receptacles, and P-10 planters.

## Mounts for Ash Receptacles — Elevated

- 1.90" OD x 11 ga. steel tube post welded to a 10 ga. steel formed mounting plate, four 7/16" bolt holes match plate in the bottom of each ash receptacle (fasteners included).
- Elevated Pedestal Mounts supports receptacles 8" above ground.
- Standard hot dip galvanized finish (/G).
- Optional powder coat finish. See Page 47.

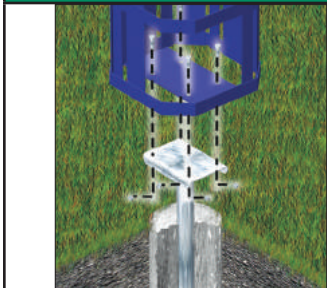
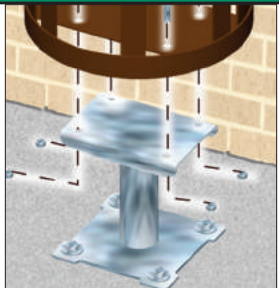
Embedded Pedestal Mount The post is embedded into a concrete footing.	Model No.	Support	Use with these Receptacle Holders	Model No.	Surface Pedestal Mount Includes a welded 1/4" x 8" x 8" base plate anchored to surface (anchor bolts not included). See Page 113.
	M10	Plate	TRH-ASH, TRQ-ASH, AMR-ASH, AMQ-ASH, CN-R/SS3-ASH	M11	



(Above) **Model RPP/W-2**, brown recycled plastic post, hardware for 2 (optional) cans.

## Trash Can Hanger — Recycled Plastic Post

- Massive 6" x 6" (nom.) x 5 ft. long post, buried 2 ft. into ground to provide solid base.
- Post and hangers support trash cans above ground. Optional trash cans available. See Page 65.
- **Model RPP** Post is 100% recycled plastic. See Page 50. Plastic post is reinforced with molded-in steel pipe.
- Post kit can be equipped to hang 1 or 2 cans. (Specify when ordering.) Mounting hardware (base plate and J-hook) is formed from 3/16" steel, hot dip galvanized. Post kit includes chain kit to secure trash can lid to can base plate. All galvanized lag bolts provided. Attach support hardware to accommodate cans of various sizes.
- Post can hold up to 4 trash cans by ordering additional hardware kits (Model WP/G-H) and chain kits (Model CK-1).

Model	Post Material	Includes hardware for	Optional Additional hardware
RPP/◆-1	Recycled Plastic	1 Can	To mount additional cans order (1) #WP/G-H hardware kit and (1) #CK-1 Chain Kit for each can.
RPP/◆-2		2 Cans	
Replace (◆) in model number with letters indicating color choice. See Page 50.			



## Trash Can Hanger — Steel Post

- **Model CH-4** Trash Can Hanger provides support for up to 4 steel trash cans.
- Central post is 1-7/8" OD steel pipe. Installs into a concrete footing.
- Steel handle hooks and bottom supports are welded to adjustable collars. The set screws in these collars allow you to adjust their positions to accommodate cans of various capacities and styles.
- Hot dip galvanized finish is standard (Model CH/G-4). Optional powder coat finish available. See Page 47.
- Optional trash cans available. See Page 65.

**Model CH/G-4** Trash Can Hanger.  
Shown with optional trash cans  
**Model CNG-2310CL**

## Anchor Stake

- **Model AH/G-3** Anchor Stake Kit is made of heavy gauge steel and 3/16" x 1-3/4" angle. Installs permanently into concrete footing. Kit includes anchor stake, two galvanized handles for barrel and fasteners.
- Will accommodate your 30- or 55-gallon barrels (not included). Optional 55-gallon barrels available. See Page 65.
- Keeps barrel off the ground to extend life. Maintains barrel upright despite tampering, rodents and wind. Also provides place to secure barrel cover (not included).
- Anchor stake has hot dip galvanized finish.
- Combine AH/G-3 kit with your barrel and our optional Trash Can Lids Model TG-19 or TG-24 (see Page 62) for a complete, economical trash collection system.

**Model AH/G-3** Anchor Stake Kit includes: stake, barrel handles and fasteners.





**Model RA3/G-PA** 3-module recycling array, gray recycled plastic post and slats. Shown with optional **Model TG-24** galvanized steel recycling and trash lids, lid decals, and padlocks.



**Model RA2/G-PW** 2-module recycling array, brown recycled plastic post and slats. Shown with optional **Model TG-24** galvanized steel recycling lids and lid decals.

## Recycling Arrays — RA Series

**Provide a focal point for recycling ... and trash collection**

- Recycling Arrays use the TRH-32 Trash Receptacle Holder as the basic module. See Page 54.
- Recycling Arrays come in three configurations, all with a center anchor post.

1-Module: **Model RA1/G-P♦** uses a single TRH-32 receptacle.



2-Module: **Model RA2/G-P♦** uses two TRH-32 receptacles.

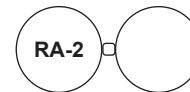

3-Module: **Model RA3/G-P♦** uses three TRH-32 receptacles.

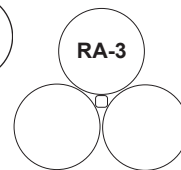

- The 4" x 4" (nom.) sq. center post of recycled plastic is the array focal point and is embedded into a concrete footing to secure the array in place. Modules bolt to the center post (and to each other for the 3-module array). Provided ground anchors, driven through holes in the base frame rings, can additionally anchor and secure the array structure.

- Each module includes galvanized steel frame rings and 1" x 4" (nom.) slats of 100% recycled plastic. See Page 50 for colors (replace "♦" with letters indicating color choice).
- **Optional:** Model TG-24 Recycling Lids can be used to collect a variety of recyclables. Our recycling decals let you identify what each module is used for (see Pages 61 and 64).
- **Optional:** Other trash can covers and dome lids can also be used to add to the versatility of the array. See Pages 60-64.
- **Optional:** Complete the Array with a selection of metal or plastic liners. See Page 65.
- **Optional:** Band-It trash bag loop to hold your trash bag in place. See Page 64.



A wide variety of plastic or steel dome and flat lids is available. Add recycling decals to equip your Recycling Array to collect recyclables or trash or both at the same time.

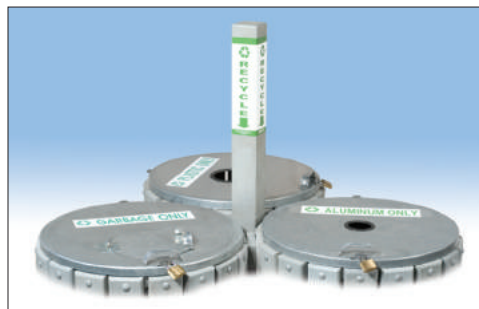

**Model RA3/G-PC** 3-module recycling array in cedar colored plastic with optional **Model CN-PD/N-24PC** green recycling lids. Also shown is optional engraved letters with green resin fill (see Page 25).



## KOLORCANS



**Model CN-S7101A/Y**  
round receptacle in yellow color.

**Model CN-S7101A/N**  
round receptacle in green color.



- Two shapes. Two sizes.
- ROUND with dome top, 42 gal. capacity.
- SQUARE with square top, 32 gal. capacity.
- Complete set: includes outer base, top and inside liner.
- Rotationally molded polyethylene plastic has solid color molded in. Won't fade, dent or chip. Durable, heavy weight material. Round unit weighs 36 lbs., square shape weighs 29 lbs. Made in USA with recycled plastic and is 100% recyclable.
- Four molded in handles for easy use. Maintenance free plastic door hinge. Self-closing door fits tightly to keep insects out. Not affected by wind.
- Signage – outer base unit includes flat panels where you can apply your signage (not included).
- **8 BOLD Solid Colors:** Blue, Green, Brown, Black, Red, Yellow, Orange, White. Base and top are same color.

Round Receptacle Model Number	Square Receptacle Model Number
Dome Top (Waste)	Square Top (Waste)
CN-S7101A/◆	CN-S7801A/◆
Replace (◆) in Model No. with letter indicating color choice. SOLID COLORS: Blue (U), Green (N), Brown (W), Black (B), Red (R), Yellow (Y), Orange (O), White (H):	



**Model CN-S7801A/R**  
square receptacle in red color.



**Model CN-S7801A/U**  
square receptacle in blue color.



**Model CN/CN-M3601-FT** receptacle (Left), green finish, 36 gallon, flat top lid. **Model CN/CB-M2401-FT** receptacle (Right), black finish, 24 gallon, flat top lid.

## Streetscape Receptacles

- These receptacles feature strong, flat steel bar construction, with a reinforcing steel tube encircling the top. Single piece, all welded construction. Ships fully assembled.
- Powder coated finish is available in 3 colors: brown, green or black.
- **Model CN-M2401** offers 24-gallon capacity. **Models CN-M3601** and **CN-M3600R** provide 36-gallon capacities.
- Receptacle kit includes: heavy rigid plastic liner, a cable anchor to secure lid to receptacle, a set of concrete surface anchors, built in leveling feet, and choice of lid.
- Choose from three styles of lids: Flat Top with center hole (FT); Flat Top with Ash Urn (AT), or Steel Dome Top with spring loaded hatch (DT). Lid colors will match the receptacle color.



Flat Top Lid (FT).

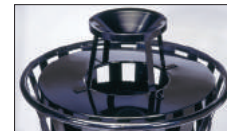

Ash Urn Top (AT).



Dome Top Lid (DT).

Model No.	Receptacle with:	Size with Top (Dia. x Ht. in.)	Cap. (Gal.)	Wt. (lbs.)
CN/◆-M2401-FT	Flat Lid Top	23 x 36	24	55
CN/◆-M2401-DT	Dome Lid Top	23 x 45-1/2		57
CN/◆-M2401-AT	Ash Urn Top	23 x 44-1/4		57
CN/◆-M3601-FT	Flat Lid Top	28 x 36	36	93
CN/◆-M3601-DT	Dome Lid Top	28 x 45-1/2		97
CN/◆-M3601-AT	Ash Urn Top	28 x 44-1/4		95
CN/◆-M3600R-FT	Flat Lid Top	28 x 36	36	93
CN/◆-M3600R-DT	Dome Lid Top	28 x 45-1/2		97
CN/◆-M3600R-AT	Ash Urn Top	28 x 44-1/4		95

Replace (◆) in model number with letter indicating color choice: Green (CN), Black (CB), Brown (CW).



**Model CN/CB-M3600R-FT** receptacle, black finish, 36 gallon, flat top lid.

- Web Site: [www.pilotrock.com](http://www.pilotrock.com)
- E-Mail: [pilotrock@rjthomas.com](mailto:pilotrock@rjthomas.com)



**Model BPR1/CW-36** bear resistant receptacle with brown textured powder coat finish, includes liner, trash bag rack, **Inset:** door open showing included plastic liner and trash bag frame. (Trash bags not included.)

## Certified Bear Resistant Trash Receptacle —

**When a bear gets into your trash you've got a BIG mess and a BIG problem.**

This bear resistant trash receptacle is designed, tested\* and certified to keep bears out. The un-bear-able features include:

- **Construction:** Heavy 14 ga. steel body fabrication. Round shape provides structural strength. Brown textured powder coat paint finish is standard. Other colors available. Ships fully assembled. Receptacle sits off the ground for extended service life.
- **Standard Equipment:** Includes 36-gallon heavy-duty rigid plastic liners. Model BPR1 includes a tilt-out frame on which you can hang plastic garbage bags if you prefer (bags not included). Four-point or six-point surface anchor base with 1/2" x 5" concrete screw anchor bolts included. Unit must be anchored to be bear proof.
- **Front Access Door:** The front door design provides easier access to the liner inside and more installation location options. On Model BPR1 the door release is inside the receptacle and accessible when the hatch is open. On Models BPR2 and BPR3 the latches are on the outside. Two latch points keep the door tightly closed.
- **Large Hatch Opening:** 16-inch diameter 10 ga. hinged hatch opens up for easy depositing of trash. The extra wide hinge keeps round lid from twisting. Includes decal of your choice, please specify. The spring loaded trigger release for hatch is covered to limit access to human fingers only.
  - **Optional:** Textured powder coat finish is available in brown (/CW), green (/CN), blue (/CU), or black (/CB) colors.
  - **Optional:** Band-It trash bag loop to hold your trash bag on the rack in the BPR1 only. See Page 64.
  - **Optional:** Recycling plate installed under hatch on 2- and 3-module receptacles only.
  - ADA compliant for forward and side reach ranges, and hatch lifting force.



Optional steel recycling plate insert is available in three sizes.  
 #BPR-PC1, 3" dia. hole.  
 #BPR-PC5, 4-3/8" dia. hole.  
 #BPR-PC6, 5-7/8" dia. hole.



**Model BPR3/CB-108** three-module trash and recycling receptacle, black textured powder coat finish.



**Model BPR2/CN-72** two-module bear proof trash and recycling receptacle green textured powder coat finish.



\*Certified by the Living With Wildlife Foundation (LWWF) and the Grizzly and Wolf Discovery Center (GWDC) using the Interagency Grizzly Bear Committee (IGBC) protocol.

MODEL NO.	MODULES	36 GAL. LINERS INCLUDED	TRASH BAG FRAME INCLUDED	COLLECT	OPTIONAL RECYCLING PLATE	DECAL CHOICES	ANCHOR KIT INCLUDED
BPR1-36	1	1	Yes	Trash	N/A	DE-29	ANC5-4
BPR2-72	2	2	No	Trash & Recyclables	1 or 2	DE-29 DE-30 DE-31	ANC5-6
BPR3-108	3	3	No	Trash & Recyclables	1, 2, or 3	DE-32 DE-33	ANC5-6



**Model CN-VDT/P/CN-32** with optional surface mount base plate, green powder coat finish, and optional **Model CNG-WHD32C** steel trash can.

## Varmint Defiant Trash Can Cover —

Keep all kinds of varmints, critters, small animals and other assorted pests out of your trash.

- **Construction:** Heavy gauge welded steel (16, 12, 10, and, 7 ga. steel) fabrication, mounted on 3-1/2" OD x 1/8" wall steel post. Brown powder coat finish is standard.
- **2 Installation Methods:**
  - **Model CN-VDT-32** uses an embedded post into concrete footing (standard);
  - **Model CN-VDT/P-32** provides a bolt down base plate (3/8" x 8" x 8") for a concrete surface (includes anchor kit #ANC5-4 set of (4) 1/2" x 5" concrete screw anchors).
- **Operation:** The heavy weight hinged cover holds your steel can down, in place. The retainer ring keeps animals from knocking the can out at the bottom. Pull the front door open and its tail closes the throat of the lid. No animal can pull open the door and reach down into the trash can. Place your trash inside the door. When it closes your trash drops into the can. The front door is weighted and balanced to close on its own.
- **Security:** The top can be padlocked in the down position so only authorized persons can lift it and empty trash. Padlock is included.
- **Remove Trash:** Pull the top backwards and it latches in the open position. Lift trash can up, out of the retainer ring, empty and replace. Lower the lid and padlock closed.
- **Optional:** We recommend using Federal Duty trash can **Model CNG-WHD32C** (not included, order separately). This heavy weight galvanized steel can is strong enough to deter most animals. See Page 65.
- **Optional:** Your choice of powder coat colors. See Page 47.
- **Optional:** Band-It trash bag loop to hold your trash bag in place. See Page 64.

*Rating: This item is not rated to be bear proof. Larger bears may be able to crush your metal can.*



Deposit your trash. The weighted door is self-closing.

The cover latches in the up position for easy one-person trash removal.



**Model CN-VDT-32** is standard installation with the embedded post into a concrete footing as illustrated. Pull the cover back to locked position. Then empty trash can.



# WASTE & RECYCLING

## Pilot Rock Pet Waste Collection Station

The complete Pilot Rock Pet Waste Station Model PWS-D006 includes:

Steel post, sign and sign bracket, aluminum bag dispenser, aluminum waste can, 50 waste can liner bags, 600 waste collection bags, all assembly hardware and instructions. Complete station installed is 72 in. tall, 14 in. wide.

### Reorder Bags

You will want to keep both bags on hand for quick refills.

### Pet Waste Roll Bags:

Fits any dispenser. 100% biodegradable, Size: 8" wide, 13" long. 200 bags per boxed roll. 10 boxes per case. Case weight = 14 lbs.

### Order Case #PWS-D001

### Waste Can Liner Bags:

100% biodegradable, 1.55 mil. Size: 27.5" wide, 29" long, black, 50 bags per box, 4 boxes per case. Case weight = 19 lbs. **Order Case #PWS-D002**



### Sign: #PWS-D008

10 in. wide, 12 in. tall, aluminum, white/forest green powder coat finish.

### Bag Dispenser:

#PWS-D003 No rust aluminum fabrication with forest green powder coat finish, screen printed signage, lockable, three dispensing openings to hold three 200 count boxes of bags, plus room to store two extra boxes of bags, 1000 bag total capacity.

### Steel Post:

Two-section solid steel, 1 in. standard hole spacing, forest green finish, 84 in. assembled length, tapered end for easy installation.

### Waste Can:

#PWS-D004 No rust aluminum fabrication with forest green powder coat finish, self closing lid, 11 gallon capacity, built in clamps hold liners in place.



Part Number	Description
PWS-D006	Complete Pet Waste Station
PWS-D003	Pet Waste Roll Bag Dispenser Only
PWS-D001	Pet Waste Bags on a Roll Case: 10 Boxes, 200 bags per box
PWS-D002	Waste Can Liner Bags Case: 4 boxes, 50 bags per box
PWS-D004	Waste Can Only
PWS-D008	Sign (Replacement)
Optional Waste Station (Not Shown)	
PWS-D022	Complete Pet Waste Station - Bags On A Card
PWS-D019	Bags On A Card Dispenser only
PWS-D020	Bags On A Card Refill, 1 case = 800 bags



## DogiPot — Economical Pet Waste Collection System

The DogiPot light weight, polyethylene pet waste removal stations are built to commercial quality standards for use everywhere dogs and their owners go.

### The complete DogiPot Pet Waste Station includes:

- Junior Bag Dispenser (400 litter bag storage capacity). Forest green color.
- Two rolls (200 bags each) of opaque green Oxo-Biodegradable litter pick up bags.
- Trash Receptacle with Lid, 10 gallon size. Forest green color.
- One box (50 count) heavy duty liner bags.
- Signage: 18" x 12" aluminum Pet Waste sign, plus instruction signage.
- Fiberglass 4' to 8' telescoping mounting post. Assembly and mounting instructions.
- Order the Complete Pet Waste Station, **Model PWS-DOGI1010**.

- For areas where you have your own trash receptacles you can install just the litter bag dispenser. Pet owners can take a bag, use it as they exercise their pet, and dispose of it in the nearest trash receptacle.
- Order the DogiPot Junior Bag Dispenser only, **Model PWS-DOGI1007-2** (includes two rolls of 200 bags each).

Order bag refills:

- **Model PWS-DOGI1402-10** Litter Pick Up Bags, 8" x 13" long, opaque green, oxo-biodegradable. 200 bags per box. Minimum order one case of ten boxes (2000 bags).
- **Model PWS-DOGI1404** Receptacle Liner Bags, 10 gal., opaque black, draw tape close, box of 50 bags.





## Safety Bicycle Rack



(Illustration) **Model BR-6SS**  
8 ft. long, single side parking  
to hold up to 6 bikes.

- The Safety Bicycle Rack is designed with gently curved arches. The base angles face down to eliminate any vertical edges.
- With a 2-1/4" inside stall width this rack will accommodate bikes in a wide variety of sizes. Models are available in single-side (to fit adjacent to walls) and double-side styles (to hold bikes on both sides). Both styles can be ganged together on the ends to supply the needed amount of parking. Bikes are parked on 16" centers per side.



**Model BR-12DS** 8 ft. long, double side parking to hold up to 12 bikes.

MODEL NO.	NO OF BIKES	SIDES OPEN	L X W X H (INCHES)	ANCHORS
BR-6DS	6	DOUBLE	48 x 20-1/4 x 12	BR-4HSA See Page 113
BR-6SS	6	SINGLE	96 x 20-1/4 x 12	
BR-12DS	12	DOUBLE	96 x 20-1/4 x 12	

- Construction: welded, fully assembled hoops of 1/2" diameter steel bar, 1/8" x 1-1/4" x 1-1/4" formed steel base angles, and hot dip galvanized finish for maximum protection from weather and bikes. Zinc plated fasteners included.
- All assembly fasteners are pointed towards the ground with nuts concealed from view inside base angle to deter theft. Shipped unassembled.
- **Optional:** Model BR-4HSA set of (4) 3/8" x 1-7/8" hex sleeve anchors to secure bike rack to concrete surface.

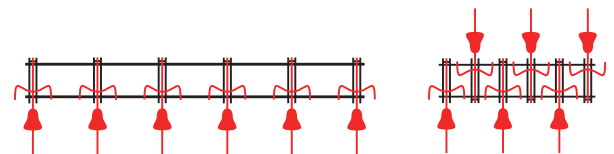

Single Sided Bike Rack

Double Sided Bike Rack

## Bike Stand

- Model BS Series Bike Stands offer a simple, low profile style.
- BS Series Bike Stands provide stalls on 16" centers (on same side):
- BSM Series Bike Stand is designed to hold mountain bikes with stalls mounted on 25-3/4" centers (on same side) to fit wider handle bars:
- **Optional:** Model BR-4HSA set of (4) 3/8" x 1-7/8" hex sleeve anchors to secure BS or BSM bike stands to concrete surface.

MODEL NO.	NO OF BIKES	SIDES OPEN	L X W X H (INCHES)	ANCHORS
<b>BS SERIES FOR STANDARD BICYCLES</b>				BR-4HSA See Page 113.
BS-3SS	3	SINGLE	34 x 25 x 17-1/2	
BS-6DS	6	DOUBLE	44 x 25 x 17-1/2	
BS-8SS	8	SINGLE	116 x 25 x 17-1/2	
BS-16DS	16	DOUBLE	124 x 25 x 17-1/2	
<b>BSM SERIES FOR MOUNTAIN BICYCLES</b>				
BSM-3SS	3	SINGLE	55 x 25 x 17-1/2	
BSM-5SS	5	SINGLE	106 x 25 x 17-1/2	
BSM-5DS	5	DOUBLE	55 x 25 x 17-1/2	
BSM-9DS	9	DOUBLE	106 x 25 x 17-1/2	



**Model BS-8SS** bike stand, 9 ft.-8 in. long,  
single side parking for up to 8 bikes.



**Model HRE/G** bike rack, embedded post installation.

## Hitching Post Bike Rack

- The Hitching Post Bike Rack is constructed from heavy 2-3/8" OD steel pipe and features a hot dip galvanized finish for maximum protection from weather and bikes.
- Each single Hitching Post will hold up to 2 bicycles of any style. Bikes can be secured at the front wheel, back wheel or frame. All popular types of securing devices may be used.
- Two installation methods are available (see below). **Model HRE/G** has a longer leg for embedment into concrete footings. **Model HRP/G** is surface mounted with bolt down base plates (3/8" dia. anchor bolts not included).
- **Optional:** Powder coat finish. See Page 47.
- **Optional:** Thermo-plastic coat finish. See Page 50. Not available with sign plate.
- **Optional:** Model ANC3-4 set of (4) 3/8" dia. x 3" heavy duty screw anchors for concrete surface. See Page 113.
- **Optional:** Welded in steel plate for your custom signage (add "S" to model number). See Page 88.

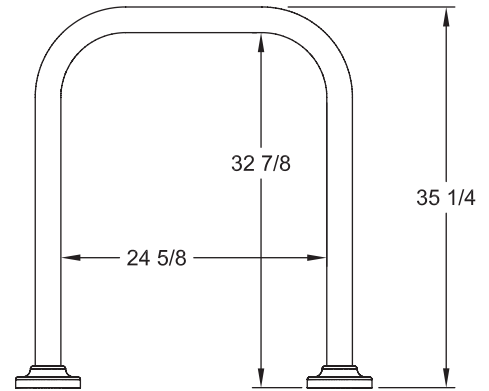

**Model HRPS/CR** bike rack with optional signage plate, powder coated red.

### Two Installation Choices



**Model HRE** racks have extended legs for embedding into concrete footings.  
**Optional:** Galvanized steel cover caps are available for each leg. Add /C to model number.

**Model HRP** racks are surface mounted by means of a bolt down base plate for use with two 3/8" anchor bolts (bolts not included). Galvanized, powder coated, or thermo-plastic coated steel cover caps are included.



## Hitching Post Group Rack

- Group the single racks together to create parking for 6 to 8 bikes.
- Features: Welded on base plates bolt to base channel, carriage bolt fasteners with nut under channel for a secure assembly, formed steel base channel is 1" x 4" (nom.) x 10 ga., holes in base channel for surface anchors, hot dip galvanized finish on all components is standard.
- Two sizes:  
**Model HRP-6** will park up to 6 bikes (66 in. long).  
**Model HRP-8** will park up to 8 bikes (96 in. long).



**Model HRP/CY-8** Group Rack, powder coated yellow, holds eight bikes.

	MODEL NO.	NO. OF BIKES	INSTALL METHOD	WIDTH (IN.)	LENGTH (IN.)	OPTIONAL ANCHOR KIT
	HRE	2	Embedded	29-3/8	NA	NA
	HRP	2	Surface Mount	33	NA	ANC3-4 (4) 3/8" X 3"
	HRP-6	6	Surface Mount	31-1/4	66	ANC2-4 (4) 3/8" X 5"
	HRP-8	8	Surface Mount		96	ANC2-6 (6) 3/8" X 5"

- **Optional:** Powder coat finish. See Page 47.
- **Optional:** Concrete screw anchors. See chart at left. See Page 113.

## Bike Block — 100% Recycled Plastic Bike Parking Stall



**Model BB-1/PR** single bike parking block molded from red recycled plastic. Park the rear wheel.

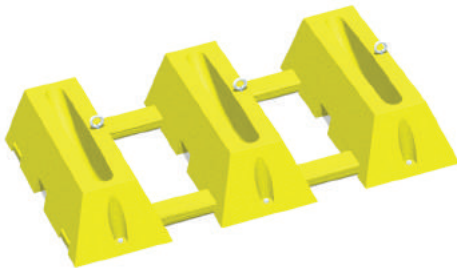

**Model BB-3/PY**, three bike parking block molded from yellow recycled plastic

- Single bike parking in a heavy weight block molded from 100% recycled plastic, available in your choice of colors. See Page 50.
- Dimensions: 12" wide at base, 6-1/2" wide at top, 8-1/2" tall, 30" long, 40 pounds.
- Bike Block wheel well will hold bikes with skinny and fat tires. Molded in drainage opening at bottom of wheel well.
- Each Bike Block includes two concrete anchor bolts and one bike security eyebolt. Once the Bike Block is anchored to the surface, access to security eyebolt is denied so bike is secure.
- Install as a single stall, or in groups of stalls – as many as you want - in any layout design you want – and in as many colors as you want.
- Multiple Bike Blocks can be ganged together to build a bike rack by bolting 3 or 4 stalls to recycled plastic 2" x 4" planks. Model BB-3/PC kit is 4 ft. long with 3 stalls. Model BB-4/PC kit is 6 ft. long with 4 stalls. (/PC indicates Cedar color, other colors available.) Each kit includes Bike Blocks, 2" x 4" planks and all fasteners for assembly.

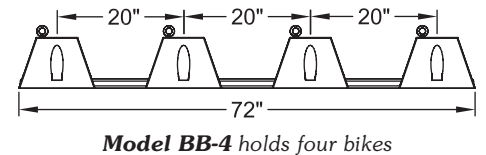
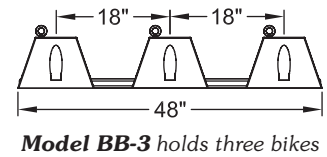
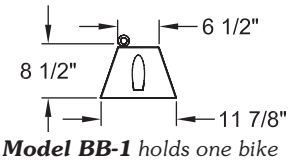

**Model BB-1/PU** single bike parking block molded from blue recycled plastic. Park the front wheel.

## Omega Bike Rack

- The Omega Bike Rack provides secure parking with classical styling.
- Each Omega Rack will hold up to 2 bikes of any size and style. All popular types of locking devices may be used.
- Available with hot dip galvanized finish for maximum protection, or with a powder coat finish in your choice of colors. See Page 47.
- The Omega can be installed singly or in groups. It lends itself to many creative landscape patterns.
- Dimensions: 32" tall at center, 36-3/4" wide at center. Fabricated using 1.90" steel pipe.
- Surface mount installation (anchor bolts, not included).
- **Optional:** Model ANC3-6 set of (6) 3/8" dia. x 3" heavy duty screw anchors for concrete surface.

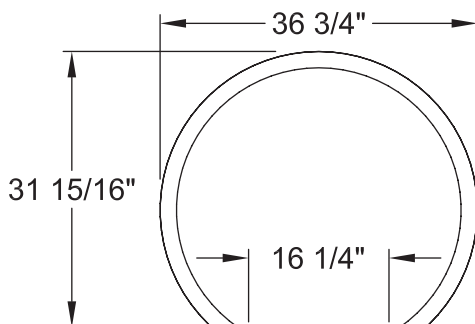

**Model ORP/CU** bike rack, powder coat blue finish.



**Model BR205SS/G** single sided hot dip galvanized bike rack with "D" style end frames. Holds five bicycles.



**Model BR210DS/G** double sided hot dip galvanized bike rack with "Bell" style end frames. Holds ten bicycles.



**Model BR220DS/CN** double sided bike rack with "Bell" style end frames. Green powder coat finish. Showing extension which doubles the parking capacity. Holds twenty bikes.

## Versatile Vertical Bike Rack

- Tall vertical stalls hold the front or back bike tire secure.
- The end frames and cross tube structures are fabricated using 1.66" OD x 10 ga. wall steel tube; the vertical stall bars are 5/8" OD steel bar (not hollow tube). All welded component fabrication. Stall structure bolts to end frames so racks ship flat to reduce freight and handling costs.
- Using the same stall structure, with interchangeable end frames, a variety of bike racks can be built – offering you choices of design and parking capacity.
- Single-sided racks will hold from 5 to 10 bikes. Double-sided racks will park from 10 to 20 bikes. See chart below.
- Double the parking capacity of a basic bike rack by adding an identical set of stalls. A matching center frame joins the stall sections together.
- Choose a finish. All rack designs are available with a powder coated paint finish in your choice of colors. See Page 47. A hot dip galvanized finish is available on some models. See chart below.
- These versatile bike racks will hold all types of bikes and most locking devices can be used.
- **Optional:** Order a set of 4 or 6 heavy-duty screw anchors to secure your bike rack to a concrete surface. See chart below.



**Model BR310DS/CU** double sided bike rack with "Wheel" style end frames. Blue powder coat finish. Holds ten bicycles.

End Frame Style	Model No.	No. of Bikes	Sides Open	Available Finish*		Profile & No. of Sections	L x W x H (in inches)	Optional H.D. Anchor Kit for Concrete
				Hot Dip Galv.	Powder Coat			
"D"	BR205SS/◆	5	Single Side	Yes (/G)	Yes	(1)	76 x 23 x 33	#ANC2-4 (4) 3/8" x 5"
	BR210SS/◆	10	Single Side	Yes (/G)		(2)	150 x 23 x 33	#ANC2-4 (4) 3/8" x 5"
"Bell"	BR210DS/◆	10	Double Side	Yes (/G)		(1)	76 x 46 x 33	#ANC2-4 (4) 3/8" x 5"
	BR220DS/◆	20	Double Side	Yes (/G)		(2)	150 x 46 x 33	#ANC2-6 (6) 3/8" x 5"
"Wheel"	BR310DS/◆	10	Double Side	No		(1)	80 x 33 x 33	#ANC3-4 (4) 3/8" x 3"
	BR320DS/◆	20	Double Side	No		(2)	153 x 33 x 33	#ANC3-6 (6) 3/8" x 3"

\*Replace (◆) in Model number with finish designation, e.g. BR205SS/G. See Page 47 for powder coat colors.



### Saddleback Bike Rack

- The Saddleback Bike Rack incorporates a graceful, continuous loop design. It will accommodate all types of bikes and all popular locking devices.
- The Saddleback Rack is formed using heavy gauge 2-3/8" OD Schl. 40 steel pipe, and offers a hot dip galvanized finish for maximum protection from weather and bikes.
- This rack can mount a bicycle at each end, plus a bike in each ascending or descending loop. Models are available to park from 3 to 13 bikes. **Model SRE/G** has a longer leg for embedment into concrete footings. **Model SRP/G** is surface mounted with bolt down base plates (3/8" dia. anchor bolts not included).
- **Optional:** Powder coat finish. See Page 47.
- **Optional:** Model ANC3-4 set of (4) 3/8" dia. x 3" heavy duty screw anchors for concrete surface. Model SRP/G-13 requires anchor kit ANC3-6.

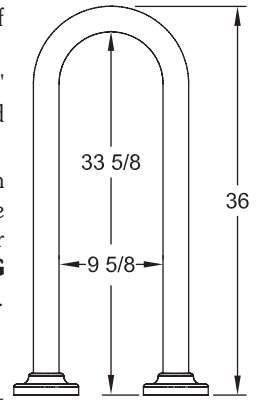

**Model SRP/G-5** bike rack, surface mount installation with base plate, includes cover caps, will park up to 5 bikes.

# of Bikes	3	5	7	9	11	13
Length (nom.)	14"	38"	62"	86"	110"	134"
Embedded Models	SRE/G-3	SRE/G-5	SRE/G-7	SRE/G-9	SRE/G-11	SRE/G-13
Base Plate Models	SRP/G-3	SRP/G-5	SRP/G-7	SRP/G-9	SRP/G-11	SRP/G-13

\*Note: Saddleback Bicycle Racks feature a nominal 12" center to center between loops. Listed lengths are nominal and may vary due to bending tolerances.



**Model SRE** racks have extended legs for embedding into concrete footings.  
**Optional:** Galvanized or powder coated steel cover caps are available for each leg. Add /C to model number.

### Two Installation Choices

**Model SRP** racks are surface mounted by means of a bolt down base plate for use with two 3/8" anchor bolts (bolts not included). Galvanized or powder coated steel cover caps are included.



### Hoop Bike Rack



**Model BR20/TU** Hoop Rack, blue thermo-plastic coat finish.

- **Model BR20** Hoop Bike Rack provides secure parking for two bikes of any size and style. All popular locking devices may be used.
- The Hoop Rack can be installed singly or in groups. Surface mount installation only (anchor bolts not included).
- Finished with thermo-plastic coating in your choice of colors. See Page 50.
- Dimensions: 30" diameter x 34" tall. Fabricated using 1/4" thick x 2-1/2" steel plate, with a 1/4" x 8" sq. steel base plate.
- **Optional:** Model ANC1-4 set of (4) 1/2" dia. x 3" heavy duty screw anchors for concrete surface. See Page 113.



# Steel Wheels

## Bike Racks



Model BR30

- The bicycle shape is something everyone will recognize for bike parking. Each rack can support the bicycle in two places. All types of locking devices may be used.
- **Fabrication:** Both bike racks use 1.66 inch OD x 10 ga. wall steel tube for the bike shapes. Fully welded assembly.
- **Finish:** Powder coated in your color choice. See Page 47.
- **Installation:** Surface mount installation only, with 3/16-inch thick steel angles welded to each wheel, providing 8 anchor points per rack for a stable and secure location .
- **Optional:** Order (2) #ANC1-4 set of (4) 1/2-inch x 3-inch concrete screw anchors. See Page 113.



Model BR31



Model BR30/CN bike rack with Green powder coat finish.

Model BR31/CE bike rack with Burgundy powder coat finish.

◀ Model BR30 will park 2 bikes.



Model BR31 ▶ will park 2-4 bikes.



	Model Number	Number of Bikes	Finish	Dimensions H x W (inches)	Installation	Optional Anchor Kit
	BR30/◆	2	Powder Coated See Page 47	41 x 50	Surface Mount. (8) anchors required per rack (not included). 9/16" dia. mounting holes	Order (2) #ANC1-4 set of (4) 1/2" x 3" concrete screw anchors See Page 113
	BR31/◆	2-4		45 x 76		

Replace (◆) in Model Number with Powder Coat Finish color choice initials. See Page 47.



**Model BR102/CR**  
bollard bike rack will park 2  
bikes. Red powder coat finish.

## Bollard Bike Rack

- Single post “bollard” type bike rack, with parking for 2, 4, or 6 bikes of any style. Will work with most bike locking devices.
- Dimensions: 35" tall, 28-1/4" wide (with two loops), 28-1/4" square (with four or six loops).
- Powder coat finish available in choice of colors. See Page 47.
- Durable steel fabrication: 4-1/2" OD x 10 ga. wall central post, 1-1/2" OD steel tube bike loops, 1/4" x 8" base plate, all welded fabrication.
- Surface mount installation, (requires four 1/2" dia. anchor bolts, not included).
- **Optional:** Model ANC1-4 set of (4) 1/2" dia. x 3" heavy duty screw anchors for concrete surface. See Page 113.

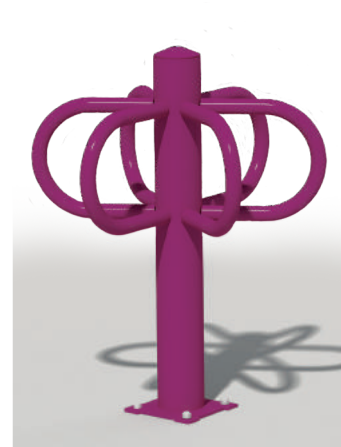

(Above) **Model BR104/CB** bollard bike rack will park 4 bikes. Black powder coat finish.  
(Left) **Model BR106/CE** bike rack holds 6 bikes. Burgundy powder coat finish.



## Car Stops

- Available in 6 ft. or 8 ft. lengths.
- Made from 100% recycled plastic. Available in 3 colors.
- Maintenance free – withstands traffic, weather and salt.
- Solid color throughout. Won't chip or fade.
- Anchor holes predrilled.
- Dimensions: 6" wide at base; 4" tall.

Model	Length (ft.)	Weight (lbs.)
CSL-6♦	6	36
CSL-8♦	8	48

Model	Length (ft.)	Weight (lbs.)
SB-6♦	6	34
SB-8♦	8	46

Color choices for Car Stops and Speed Bumps	Yellow (PY)	Gray (PA)	Blue (PU)
	Replace (♦) in model number with letters indicating color choice		

- **Optional:** Model ANC10-3 set of three 3/4" x 17-3/4" steel anchor stakes for car stops.
- **Optional:** Model ANC11-3 set of three 3/4" x 17-3/4" steel anchor stakes with head for speed bumps.
- **Optional:** Model ANC12-3 set of three 3/4" x 24" steel anchor stakes with head for car stops.

## Speed Bumps

- Available in 6 ft. or 8 ft. lengths.
- Made from 100% recycled plastic. Available in 3 colors.
- Maintenance free – withstands traffic, weather and salt.
- Solid color throughout. Won't chip or fade.
- Anchor holes predrilled.
- Dimensions: 10" wide at base; 2" tall at center.

## Certified Bear Resistant Food Storage Lockers New!

These Food Storage Lockers have been designed ... and tested ... to keep bears out. The un-bear-able features include:

**Construction:** The top, sides and door panels are all fabricated using heavy 12 ga. steel plate. The bottom panel is 12 ga. pre-galvanized steel. The corner braces/leg posts are 12 ga. steel formed channels nested inside the formed channel side panel wraps. This design assembly creates strength and rigidity for the box. All welded assembly. Only the galvanized bottom panel is bolted in.

**Door Features:** Full swing doors ride on heavy gauge zinc coated, full-length piano hinges. The latch door is reinforced with a steel angle. The doors can be opened with one hand and comply with ADA guidelines for reach and operability. Doors are easy to swing closed. For safety, the door latch can be disengaged from inside.



Hooks cut into top support channel inside the locker hold bags for access and organizing supplies.

**Model BPFL/CN-30** Bear Resistant Food Locker with textured green powder coat finish. 30 cu. ft capacity.

Two **Model BPFL/CU-15** Bear Resistant Food Lockers with textured blue powder coat finish stacked to save space with a smaller footprint. 15 cu. ft capacity each for a total of 30 cu. ft. Turn them in opposite directions to serve two campsites.

### More Features:

- Four leveling feet so you can adjust for an uneven surface.
- Set of four 1/2" x 5" concrete screw anchors (#ANC5-4).
- Locker Ceiling is reinforced with formed steel channel that includes hooks for hanging packages of dry goods.
- Wide doors provide easy access for large coolers.
- Room inside the locker to open the cooler lid without lifting it out.
- Air louvers in back panel provide ventilation but restrict insect access.
- Two like size units can be stacked to provide double the storage capacity on less space.



**Finish:** Textured powder coat finish available in four colors: brown (/CW), green (/CN), black (/CB) and blue (/CU). Pre-galvanized steel bottom panel is not painted.



**Model BPFL/CW-25** Bear Resistant Food Locker with textured brown powder coat finish. 25 cu. ft capacity. No need to lift heavy coolers out of the locker - open cooler lids inside.

Model	Inside Capacity (Cu. Ft.)	Number of Doors	Locker Box Outside Dimensions HxWxD (in.)	Overall Height	Anchor Kit Included
BPFL/◆-15	15	1	33 x 26 x 34-1/2	40-3/8 (in.) (levelers not engaged)	ANC5-4
BPFL/◆-25	25	2	33 x 47-3/4 x 30-1/2		
BPFL/◆-30	30	2	33 x 47-3/4 x 37-1/2		

Replace "◆" with letters indicating color choice; Brown (CW), Green (CN), Black (CB), Blue (CU).



Lantern Poles... Single, Double, Accessible



**Rules Plate Option:**  
Use **Model RP/G** for posting park regulations, notices and fees. This 6" x 12" steel plate is fastened to the pole at eye level and provides a flat surface for decals or adhesive signs. Fits any diameter pole. Requires drilling to retrofit in field.

**Shelf Option:**  
**Model LHS/G-1** makes the lantern holder even more functional with a 14" x 20" utility shelf, supported by two gussets welded to the adjustable attachment sleeve. Fits any 2-3/8" OD pole.

Shown: **Model LH/G-1/A:** Model LH/G-1 lantern holder with welded on Wheelchair Accessible Option - an additional lantern arm and hook. This lower position accommodates persons in wheelchairs. **This welded on option is available on all new holders.** (Add "A" to the end of any model number.)

Shown: **Model LH/G-1** with hot dip galvanized finish. **Model LH-1** features a 90-degree bend and hangs one lantern. Hook is 76" high. **Model LH/G-1:** hot dip galvanized finish. **Model LH/CB-1:** black powder coat finish.

Shown: **Model LH/G-180** with hot dip galvanized finish. **Model LH-180** features a 180-degree bend and hangs one lantern. Hook is 79-1/2" high. **Model LH/G-180:** hot dip galvanized finish. **Model LH/CB-180:** black powder coat finish.

Shown: **Model LH/CB-2** with black powder coat finish. **Model LH-2** includes a crossbar with arms curved down at 90 degrees to hang two lanterns. Hooks are 77" high. **Model LH/G-2:** hot dip galvanized finish. **Model LH/CB-2:** black powder coat finish.

**Bolt On Wheelchair Accessible Arm/Hook**

Bolt on this arm to any 2-3/8" OD pole in the field to add a lantern hook at a wheelchair height. Order **Model LHA/G-1**



- Lantern Holders are designed to safely hang camping lanterns. The 2-3/8" OD steel pipe of each Lantern Holder is installed in a concrete footing to provide a strong, vandal resistant support. The lantern hook is fabricated from 1/2" dia. steel bar.
- Lantern Holders feature single piece, welded construction and come standard with a hot dip galvanized finish to minimize maintenance requirements. An optional powder coat finish is available. See Page 47.

## Traffic Barrier

- In upright position use the traffic barrier to block traffic to restricted areas.
- Fold it down to allow traffic through.
- Can be securely locked in either position.
- Features: Heavy gauge steel fabrication, 3-1/2" OD x 1/8" wall steel pipe post; 10" sq. x 3/8" steel base plate with four 25/32" dia. holes, four 1/2" x 3" screw type concrete anchors (reorder # ANC1-4), stainless steel bolt and 3/4" dia. pin, brass padlock, high visibility yellow powder coat paint finish, reflective decals.
- Dimensions: Erect height 42-3/8", folded height 4-3/16".
- **Optional:** Powder coat paint finish in choice of colors. See Page 47.



**Model TB/CY-1** Traffic Barrier will help you block motorized traffic to restricted areas. Shown above in lowered position to allow authorized vehicles to pass.

## Bollard Barricade — Control or deter traffic with this imposing bollard post barricade



**Model TB/CY-2**  
Embedded Mount  
Bollard Traffic  
Barricade

- 4-1/2" OD x 10 ga. wall steel pipe post stands 41-3/8" tall after installation.
- **Two installation methods:**
  - **Model TB-2** provides standard post to be embedded into concrete footings. Post is open on one end so you can fill it with concrete if desired.
  - **Model TB/P-2** offers optional bolt down surface installation with welded on 3/8" thick x 10" square base plate; 3" dia. hole in this plate allows you to fill post with concrete before installation if desired; includes set of (4) 1/2" x 5" concrete screw anchors (reorder #ANC5-4).
- Yellow powder coat finish is standard. Other colors available. See Page 47. Each post includes a set of reflective decals.

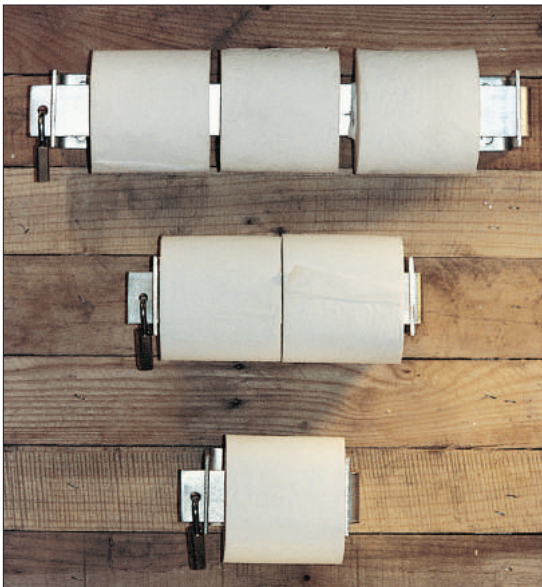

## Toilet Tissue Dispensers

- **Model TH** Toilet Tissue Dispensers are made with sturdy steel wall brackets and cross bars to stand up to abuse. The optional Model PL-1 brass padlock will prevent theft.
- Toilet Tissue Dispensers are available in 3 models to hold from 1 to 3 rolls. See the chart below. **Models TH-1** and **TH-2** use 3/16" thick steel wall brackets and 3/16" x 2" wide cross bar. **Model TH-3** has 3/16" thick wall brackets that span 16" wall stud centers and a 1/4" thick x 2" wide cross bar. Model TH-3 can serve as a paper towel holder.
- The 2- and 3-roll models can be equipped with a 1-1/2" wide cross bar which will allow the tissue rolls to turn easily. Order **Models TH-2F** or **TH-3F**. See chart below.
- All models have a zinc plated finish. Wall mounting fasteners are not included.

Shown: **Model TH-3:** Triple Roll Dispenser  
**Model TH-2:** Double Roll Dispenser  
**Model TH-1:** Single Roll Dispenser  
with optional Model PL-1 padlock

Model No.	Number of Rolls	Cross Bar Dim. (in.)	Feature
TH-1	1	3/16 x 2	Rolls won't turn easily, prevents waste and extreme use.
TH-2	2	3/16 x 2	
TH-3	3, or 1 roll paper towels	1/4 x 2	
TH-2F	2	1/4 x 1-1/2	Rolls turn easily, accommodates elderly or disabled persons
TH-3F	3, or 1 roll paper towels	1/4 x 1-1/2	



**Model P-10/G-TP Planter**, galvanized steel frame, treated pine slats.



**Model P-22/CU Planter**, steel strap design with flared top, powder coated blue.



**Model P-23/TN Planter**, wave steel strap design, thermo-plastic coated green.

## Planters — Add some color and flair to your landscape.

- **Model P-10 Series Planters** match our round TRH Series trash and recycling receptacles. See Page 54. Top and bottom steel frame rings can be galvanized or powder coated in your color choice. The slats are 2" x 4" (nom.) available in treated pine or colorful 100% recycled plastic. See Page 50. Assembly is required. Dimensions: 25" tall x 26-1/2" OD (nom.). A heavy duty rigid plastic liner is included. *Match with wood and plastic benches on Pages 8-9.*

- **Model P-20 Series Planters offer two designs:**

- **Model P-22 Planter** is designed to coordinate with the round CN-R/SS2-36 steel strap trash receptacle (See Page 52). Features include: all steel and all welded fabrication, attractive flare top, and a durable powder coat finish in your color choice. See Page 47. Ships fully assembled. Dimensions: 23" tall x 29" OD (nom.). Includes four leveling feet. A heavy duty rigid plastic liner is included. *Match with steel strap benches on Pages 20-21.*

- **Model P-23 Planter** is designed to coordinate with the round CN-R/SS3-36 steel strap trash receptacle. See Page 59. Features include: all steel and all welded fabrication, new die formed wavy vertical straps, and a durable thermo plastic coat finish in your color choice. See Page 50. Ships fully assembled. Dimensions: 25-1/2" tall x 29" OD. Includes four leveling feet. A heavy duty rigid plastic liner is included.

- **Model P-30 Series Planters** mirror the design of our Oak Knoll trash receptacle (see Page 57), including the durable vertical steel bar construction and the circle of rosettes around the top. Heavy gauge steel components and welded fabrication creates a planter as durable as the Oak Knoll trash receptacle. The Planter does not have a side opening door. Select your choice of powder coat finish colors. See Page 47. Ships fully assembled. Dimensions: 25" tall x 27" OD (nom.). A heavy duty rigid plastic liner is included. *Match with the Oak Knoll bench frame on Page 21.*



**Model P-10/G-PY Planter**, galvanized steel frame, yellow recycled plastic slats.



**Model P-30/CR Planter**, steel bar and rosettes design, powder coated red.



All planters include this 20" tall x 20" (nom.) diameter heavy duty rigid plastic liner, black color only. For replacement order **Model CN/B-3001**.

## Enjoy the Outdoors with Benches that match with our Planters.

See our versatile Channel Bench on Pages 8-9.



For steel Strap benches see our Gillette Bench on Page 20.



The Oak Knoll Bench frames have rosettes matching the P-30 Planter. See Page 21.





**Model ULT/B-2** with 18" x 48" work top, single post, standard embedded installation.

## Utility Table — ULT Series

- **Model ULT** Utility Tables are a popular enhancement to picnic and camp sites by providing a work area so the nearby picnic table can be kept clean and used for other activities. The table is 32" high (nom). These are popular Dutch Oven or Grill tables.
- Simple design makes the ULT Table convenient to use, easy to keep clean. Rugged construction includes: 3/16" thick steel plate top, steel tube or channel iron leg posts. Finish: high heat black enamel paint. Some assembly required.
- Formed 1-3/4" flanges on all four sides reinforce the top for strength. The side and back flanges are formed up to define the work area, the front flange is formed down to offer a blunt front edge and the back corners are left open for easier clean up.
- Embedded post installation is standard.
- **Optional:** Bolt down steel base plate installation for existing surface (anchor bolts not included, use one or two #ANC1-4 kit). See Page 113.
- These fixed position Utility Tables come in 3 styles:
  - **Model ULT-1:** 18" deep x 30" wide top; single 4" x 6" rectangular steel tube post.
  - **Model ULT-2:** 18" deep x 48" wide top, single 4" x 6" rectangular steel tube post.
  - **Model ULT-3:** 30" deep x 48" wide top, double 6" steel channel posts. Top is reinforced underneath with two 3/16" x 3" x 3" steel angle.



(Right) **Model ULT/P/B-3** with 30" x 48" work top, double post, shown with optional bolt down base plate installation.

ULT Series Utility Tables are great locations for Dutch Ovens and portable Charcoal Grills.



(Right and photo at left) **Model ULT/P/B-1** with 18" x 30" work top, single post, shown with optional bolt down base plate installation.

## Utility Table with Swivel Top

**Model ULT-4** utility table offers these features:

- **Swivel:** 360-degree rotation in either direction with theft proof swivel attachment on 3-1/2" OD steel post. You can compensate for changing light or wind conditions.
- **Taller working height:** 40" (nom.) installed (still within ADA guidelines).
- **Table dimensions:** 3/16" thick steel plate x 18" deep x 30" wide, with formed flanges on all sides for strength.
- **Table Features:** The formed-up flanges on 3 sides help contain your food and utensils. The front formed-down flange presents a blunt front working side.
- **Finish:** High heat black enamel paint.
- **Standard:** **Model ULT/B-4** with standard embedded post installation.
- **Optional:** **Model ULT/P/B-4** with optional surface mount bolt down base plate installation (anchor bolts not included – use #ANC1-4 kit). See Page 113.

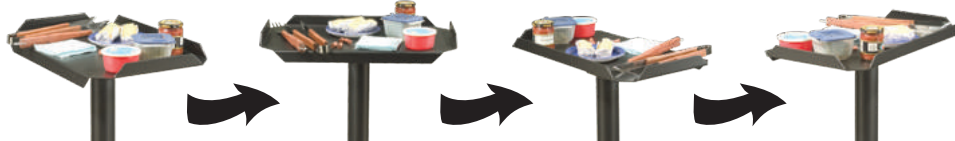

**Model ULT/P/B-4** with optional surface mount bolt down base plate installation.

## Full Size Utility Table — APTX Series

A full size serving or prep table

- **Model APTX** utility tables available in 6 or 8 ft. lengths, 30" (nom.) table top height. These larger utility tables can provide work or prep area for several people at the same time.
- Uses the APT Series picnic table top frame (see Page 42) double pedestal 3" x 6" (nom.) rectangular steel tube frame posts. Standard embedded installation. Optional bolt down base plate available (anchor bolts not included, see Page 113).
- Frame finishes available: hot dip galvanized or powder coat. See Page 47 for colors.
- Top materials available: lumber, aluminum, 100% recycled plastic, or thermo-plastic coated expanded steel, perforated steel, or formed steel channel. See Pages 48-50 for colors.



**Model APTX/P/G-6HU** optional bolt down base plate installation, galvanized frames, 6 ft., thermo-plastic coated perforated steel in blue.



### SNOW LOAD RATED TABLE

When equipped with V-Type expanded steel, or H-Type perforated steel top/seats. See Page 32.

## Utility Table — XTX Series

A portable or stationary work table up to 10 ft. long

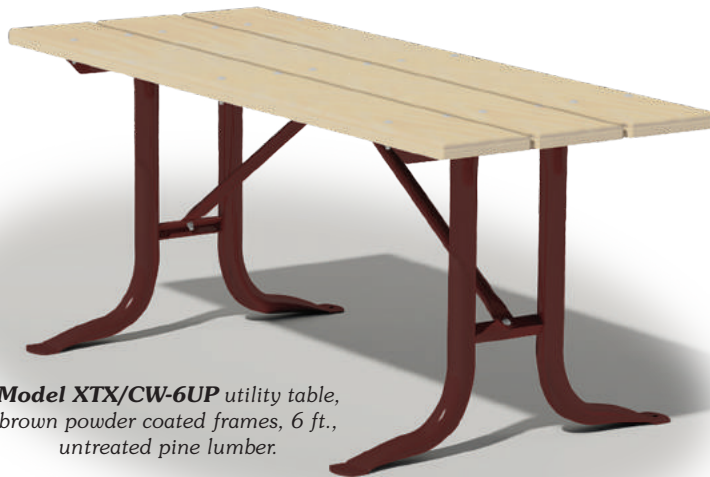

**Model XTX/CW-6UP** utility table, brown powder coated frames, 6 ft., untreated pine lumber.

- **Model XTX** Utility Table is a durable and versatile design variation of our XT Series Picnic Tables (see Page 29).
- Features include: 2-3/8" OD x 11 ga. wall welded steel pipe end frames, 1-5/16" OD diagonal braces, hot dip galvanized frame finish is standard, includes galvanized fasteners. Top is 30" high (nom.). Table can be 6, 8 or 10 ft. long (depending on material choice).
- Top materials for 6, 8 and 10 foot: lumber, aluminum, and thermo-plastic coated expanded steel and perforated steel. Top materials for 6 and 8 foot: recycled plastic or thermo-plastic coated formed steel channel. See Pages 48-50 for color choices.
- Wide stance frame with formed and flattened feet provide a stable portable table. The frame feet include 9/16" dia. holes for anchors (not included, see Page 113) for a secure surface bolt down installation.

## Grill Station — Series GS

A Utility Table and Grill in one!  
See Page 100.



This all new concept in outdoor cooking combines a charcoal grill with a work table to create one convenient Grill Station.

**To protect your picnic table from heat damage use our Heat Shield. See Page 46.**



- Web Site: [www.pilotrock.com](http://www.pilotrock.com) •
- E-Mail: [pilotrock@rjthomas.com](mailto:pilotrock@rjthomas.com) •























































## Trail and Marker Signs

- Square marker sign material is .120" thick with laminated white aluminum on both surfaces and a solid black polyethylene core.
- Vinyl is 3M brand high performance vinyl with a 7-year warranty.
- Sign image is on one side only. Sign vinyl is available in 3 colors: brown, green and blue. Sign background colors will be white. Type will be reversed on sign.
- Three sign sizes: 3" or 9" or 12" square.
- Two mounting holes: 3" sign has two 3/16" dia. screw holes; 9" and 12" signs have two 3/8" bolt holes. Fasteners are not included.
- **Optional:** Sign posts and fasteners. See Page 87.



	BROWN	GREEN	BLUE	Optional Sign Posts Available
Size	Model Number			
3" Square	SN-M/W3-###	SN-M/N3-###	SN-M/U3-###	SN-PP44 Only
9" Square	SN-M/W9-###	SN-M/N9-###	SN-M/U9-###	SN-PFC-8, SN-PSO-8, SN-PP44, or SN-PP66
12" Square	SN-M/W12-###	SN-M/N12-###	SN-M/U12-###	
<i>Replace "###" in part number with Symbol number of choice.</i>				

MEN'S ROOM #101	WOMEN'S ROOM #102	REST ROOMS #103	SHOWERS #104	LAUNDRY #105	LOCKER #106	PHONE #107	HOSPITAL #108	FIRST AID 1 #109	FIRST AID 2 #110
ALCOHOL #111	FOOD #112	GROCERIES #113	LODGING #114	AMPHITHEATER #115	WHEELCHAIR ACCESS #116	CHANGING STATION #117	DRINKING FOUNTAIN #118	FIRE EXTINGUISHER #119	MAILBOX #120
RECYCLE #121	WI-FI HOT SPOT 1 #122	WI-FI HOT SPOT 2 #123	WI-FI HOT SPOT 3 #124	POISON #125	ATM #126	SMOKING #127	LITTER CONTAINER #128	ARCHEO-LOGICAL SITE #129	BEAR-VIEWING AREA #130
DEER-VIEWING AREA #131	WATCHABLE WILDLIFE #132	FISH #133	INFORMATION #134	SCENIC AREA #135	TRAIL SHELTER #201	SLEEPING SHELTER #202	LOCAL FIREWOOD #203	TENT AREA #204	PICNIC SHELTER #205
CAMPER PARKING #206	RV SANITARY STATION #207	PICNIC TABLE #208	ELECTRICAL HOOKUP #209	CAMPING #210	TENT CAMPING #211	PICNIC AREA #212	DRINKING WATER #213	LOOKOUT TOWER #214	NATURE STUDY #215
TRAIL INFO #216	FIREARMS #217	WEAPONS #218	RANGER STATION #219	CAMP FIRE #220	KENNEL #221	LEASHED PETS #222	DOGS / PETS #223	DIAGONAL ARROW RIGHT #301	DIAGONAL ARROW LEFT #302
DIRECTIONAL ARROW #303	LEFT OR RIGHT ARROW #304	UP OR DOWN ARROW #305	WARNING CAUTION #306	TRUCKS #307	AUTOMOBILES #308	PEDESTRIAN CROSSING #309	TUNNEL #310	BUS STOP #311	PARKING #312

 PICKUP #313	 TRANSIT BUS #314	 FUEL #315	 OFF ROAD #316	 SCOOTERS #317	 BICYCLE #318	 BOAT DOCK #319	 MOTORCYCLE #320	 MOTORCYCLE PARKING #321	 BOAT RAMP #322
 ATV ICON #323	 ATV LETTERS #324	 LIFE JACKET #325	 LIFE PRESERVER #326	 DAM #327	 GOLF COURSE #401	 TUBING #402	 DIVING #403	 SURFING #404	 SWIMMING #405
 SCUBA DIVING #406	 SAILING #407	 HIKING TRAIL #408	 HORSE TRAIL #409	 STABLES #410	 BOATING #411	 CANOEING #412	 FISHING #413	 ICE SKATING #414	 SKI JUMPING #415
 SNOW SHOEING #416	 SNOW BOARDING #417	 DOWNHILL SKIING #418	 CROSS COUNTRY SKIING #419	 SNOWMOBILING #420	 SKI BOBBING #421	 WINTER RECREATION AREA #422	 CHAIR LIFT #423	 DOG SLEDDING #424	 SNOW TUBING #425
 SLEDDING #426	 MOUNTAIN BIKE TRAIL #427	 ROCK CLIMBING 1 #428	 ROCK CLIMBING 2 #429	 FALLING ROCKS #430	 BASEBALL SOFTBALL #431	 BIKE TRAIL #432	 SKATE BOARDING #433	 TENNIS #434	 PLAYGROUND #435
 NO / NOT ALLOWED X					Add the "NO" icon to any sign —			— to show activities and services that are not available.	
									Example: #323X

## Need A Post For Your Sign?

We offer four types of posts for your marker signs – 4" x 4" or 6" x 6" square 100% recycled plastic posts, fiberglass or steel posts. Refer to this chart for post details and sign sizes.

MODEL	DESCRIPTION	WT. (lbs.)	Signs Available
SN-PP44	Recycled plastic 4" x 4" (nom.) square, can be 5, 6, or 8 ft. long. Specify length and color (see Page 50).	22 (5') 27 (6') 36 (8')	3, 9, and 12 in. square signs
SN-PP66	Recycled plastic 6" x 6" (nom.) square, 8 ft. long. Specify color (see Page 50).	78	9 and 12 in. square signs only
SN-PFC/N-8	Fiberglass, closed channel, green color, 8 ft.	6	
SN-PSO/N-8	Steel, open channel, green baked on enamel, 8 ft.	16	
#900-077	Fastener Package for Steel and Fiberglass Post, set of (8) 5/16" x 2-1/2" zinc plated slotted machine screw with nut.	1	



(Left) **Model SN-PFC/N-8** fiberglass closed channel post.  
(Right) **Model SN-PSO/N-8** steel open channel post.

## CUSTOM BANNERS

Durable vinyl banners are a great way to promote special events. We use 15 oz. nylon webbed vinyl in bright white to really make your custom graphics pop. Use your custom banner inside or outside, at trade shows, public and seasonal events, ceremonies, concerts, sales promotions and ...well, it's up to you. These banners are economical so you can afford to change them often, but they are durable so you can use and reuse them many times. Our price includes digital printing of your custom graphics, and grommets to hang and secure your banner. Standard sizes are 36" wide x 72" or 96" or 120" long, and 48" wide x 72" or 96" or 120" long. Custom sizes are also available.



## ENGRAVED SIGN POSTS & RECYCLED PLASTIC

These square sign posts are molded from 100% recycled plastic and available in any of our standard colors. See Page 50. Use them for information along trails and golf courses. They create a simple, durable sign that will never rust or rot. Engraved letters with contrasting colored resin fill make your message visible and attractive. Some emblems and images can be engraved, too. Sign posts come in two sizes: 4" x 4" nom. (5, 6 or 8 ft. lengths), and 6" x 6" nom. (8 ft. only). But don't limit yourself to engraved sign posts! We can also provide custom messages on plastic planks for benches, trash receptacles and more. Be creative. Also see Page 25.



## CUSTOM DECALS & PLAQUES

Custom decals and plaques are a great way to recognize a donor, memorialize a loved one, promote an organization, or identify ownership. We offer a variety of custom plaques in two materials: Cast metal plaques can be round or rectangular, come in several colors, and can include detailed laser engraving; or Laminated plaques are a 3-ply plastic in your choice of surface and core colors, and can include a photo. Custom decals can be printed to your design specifications and lend themselves to many applications from park equipment to vehicles to ...well, you decide. Size and shape are up to you. Also see Page 25.







**Model ASW-20 B2** Accessible Grill with single level swivel grate, meets the ADA guidelines for access, reach, and operability. Shown with optional **Model S6** Swivel Shelf.



**Accessible Grill — ASW Series**

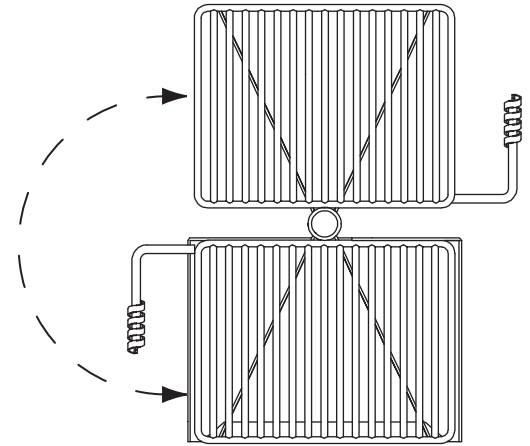

Grate rotates 180° out of the fire. The grate handle is never over the fire.

- **Model ASW-20** offers 300 sq. inches of cooking area on the single level swivel grate. The cooking grate swivels 180 degrees – over the charcoals or completely out of the firebox – but the grate handle is never over the heat.
- The cooking grate requires less than 5 lbs. of force to move, and requires only one hand to operate. The cooking surface is less than 34" high.
- The firebox rotates 360 degrees in either direction on theft proof swivel attachment. Standard 3-1/2" OD x 40" long base post for embedded installation (B2).
- The firebox is 6" high on the swivel side, and 10" high on the other side to provide wind protection above the grate.
- All welded firebox construction: 3/16" (7 ga.) thick steel, plus die-formed flange to retain ashes and reinforce the firebox from heat.
- All welded cooking grate fabrication: 1/2" diameter solid steel bars, mounted on steel tube allowing it to swivel 180 degrees. The operator handle includes a 1/8" x 1/2" flat bar coiled spring grip. All grate bars are welded on both sides.
- Finished with high temp, non toxic black enamel paint.
- **Optional:** Model B18 surface mount base post (instead of standard embedded post). Surface anchor bolts are not included. Becomes Model ASW-20 B18.
- **Optional:** Swivel shelf Model S6 installs on 3-1/2" OD base post.



**Model ASW-20 B2**

Firebox Dimensions (D x W x H) . . . . .	15" x 20" x 6"-10"
Cooking Area (Sq. In.) . . . . .	300
Finish . . . . .	High-Temp Enamel
Vertical Grate Adjustment . . . . .	None
Horizontal Grate Adjustment . . . . .	180°
Weight . . . . .	76 lbs.
Optional Shelf. . . . .	S6
Base Options . . . . .	B2 (Standard), B18



**Model B2**  
Embedded  
Base

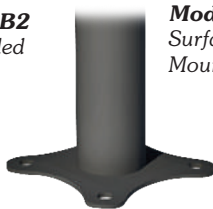

**Model B18**  
Surface  
Mount Base



**Model S6**  
Swivel Shelf

This charcoal grill has been designed to meet the rules presented in the Draft Final Accessibility Guidelines for Outdoor Developed Areas 1011.3 (ADA-ABA 309.4) and 1011.5 (ADA-ABA 902.3) as presented by the U.S. Access Board Oct. 19, 2009.

## Infinitely Adjustable Grate — A, B, C, D Series



(Above) **Model A-20/S B2** Premier Park Grill with Infinitely Adjustable cooking grate, shown with optional bolt on utility shelf.

(Right) **Model C2-36/SS B2** Premier Park Grill with two Infinitely Adjustable cooking grates, shown with optional bolt on utility shelves.



Fire Building and Cleaning Position

Cooking Height Range

(Right) **Model D2-48/SS B2** Premier Park Grill with Infinitely Adjustable cooking grates, shown with two optional bolt on utility shelves.



- The original Infinitely Adjustable cooking grate design, adjusts the cooking surface anywhere from just above the coals to 12 inches above bottom of firebox.
- Cooking Grate tips back out of firebox yet remains attached, for easier fire building and clean out.
- Structurally reinforced cooking grate is virtually indestructible. Grate accepts punishment from vandals without failure.
- Double Reinforced Firebox: First the bottom is ring reinforced to dissipate heat and prevent warpage. Second, integral formed flanges in front, sides and back panels provide increased field strength. The larger Models C2-36 and D2-48 include additional reinforcing ribs.
- Full 360-degree rotation in either direction, on theft-proof swivel attachment. Standard 3-1/2" OD x 40" long base post for embedded installation (B2 in model number).
- Coiled handle grips are fabricated from 1/8" x 1/2" steel bar (not wire springs).
- All-welded firebox and grate construction. No rivets or bolts. Firebox is fabricated from 3/16" thick (7 ga.) steel. Grate is constructed using 5/8" dia. perimeter and handlebars and 1/2" dia. center bars. Model D2-48 uses 3/4" dia. handlebars. All grate bars are welded on both sides.
- Entire unit is finished with high temp non-toxic black enamel paint.
- Available options include: Surface mount, portable or caster bases; Bolt on utility shelves; swivel shelf. See illustrations below.

(Illustration) Pilot Rock Premier Park Grills feature the original Infinitely Adjustable cooking grate. Grate can be adjusted from just above the coals to as much as 12" above bottom of firebox. Grate lifts over and out of firebox but remains permanently attached.



**Model B2**  
Embedded Base  
(Standard on all models)

**Model B3**  
Surface Mount Base



**Model B14**  
Caster Base

**Model B4**  
Portable Disk Base

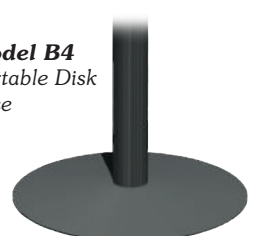



**Model A-20/S B2**  
with optional shelf

Firebox Dimensions (D x W x H) . . . . . 16" x 20" x 8"  
 Cooking Area (Sq. In.) . . . . . 320  
 Vertical Grate Adjustment  
 from Bottom of Firebox . . . . . 3-3/4"-12"  
 Weight . . . . . 83 lbs.  
 Optional Shelf . . . . . (1) S1, (1) S6  
 Base Options . . . . . B2 (Standard), B3, B4



**Model B-24/S B2**  
with optional shelf

Firebox Dimensions (D x W x H) . . . . . 16" x 24" x 8"  
 Cooking Area (Sq. In.) . . . . . 384  
 Vertical Grate Adjustment  
 from Bottom of Firebox . . . . . 3-3/4"-12"  
 Weight . . . . . 91 lbs.  
 Optional Shelf . . . . . (1) S1, (1) S6  
 Base Options . . . . . B2 (Standard), B3, B4

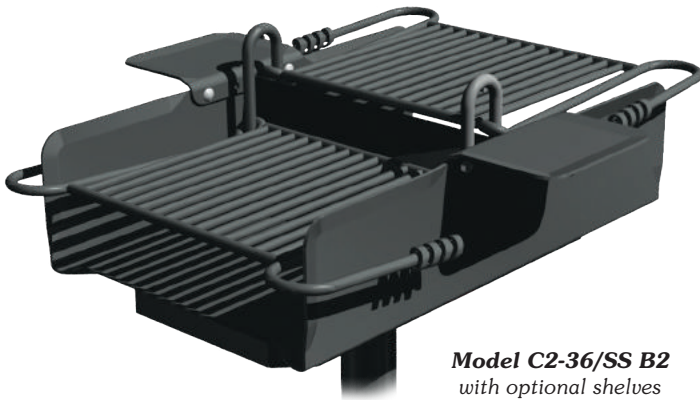

**Model C2-36/SS B2**  
with optional shelves

Firebox Dimensions (D x W x H) . . . . . (2) 16" x 20" x 8"  
 Cooking Area (Sq. In.) . . . . . 640  
 No. of Grates . . . . . 2  
 Vertical Grate Adjustment  
 from Bottom of Firebox . . . . . 3-3/4"-10-1/2"  
 Weight . . . . . 145 lbs.  
 Optional Shelf . . . . . (1 or 2) S1  
 Base Options . . . . . B2 (Standard), B3, B4, B14



**Model D2-48/S B2**  
with optional shelf

Firebox Dimensions (D x W x H) . . . . . 32" x 32-1/2" x 8"  
 Cooking Area (Sq. In.) . . . . . 1040  
 No. of Grates . . . . . 2  
 Vertical Grate Adjustment  
 from Bottom of Firebox . . . . . 3-3/4"-12"  
 Weight . . . . . 214 lbs.  
 Optional Shelf . . . . . (1 or 2) S2  
 Base Options . . . . . B2 (Standard), B3, B4, B14



**Model S6**  
Swivel Shelf



**Model S1**  
7-1/8" x 9-5/8"  
Shelf



**Model S2**  
9" x 20" Shelf

## MultiLevel Grills — N Series



**Model N-20/S B2** multilevel grill with optional **Model S3** utility shelf.



**Model N-20 B2** multilevel grill, with optional **Model GC/B-1** grill cover, and optional **Model S6** swivel utility shelf.



**Model NS-20 B6S** multilevel grill, stainless steel firebox and post.

- Two sizes: **Model N-20** provides 300 sq. in., and **Model N-24** provides 432 sq. in. of cooking area on the four level adjustable cooking grate.
- Model N-20 is available with the standard high-temp black enamel finish; or with a hot dip galvanized firebox and post; or with a stainless steel firebox and post. Model N-24 is available with the high-temp black enamel finish or with galvanized firebox and post.
- Stainless steel grill **Model NS-20 B6S** is designed for areas where the natural environment is especially corrosive to (carbon) steel. The stainless steel can retard the onset of "rust out" so the grill remains functional longer, reducing maintenance and replacement costs.
- All N-Series grills are permanently attached to the base post with our unique theft-proof swivel mechanism providing a continuous 360-degree rotation in either direction. Embedded installation of post is standard. Models N-20 and N-24 use a 3-1/2" OD x 40" post. Model NS-20 is mounted on a 2-3/8" OD x 40" long stainless steel post.
- All-welded firebox construction. The N-20 and N-24 firebox is fabricated from 3/16" (7 ga.) thick steel. Model NS-20 grill uses 304 grade 3/16" stainless steel for the bottom and 1/8" thick 304 stainless steel for the sides of the firebox. All designs include integral die-formed flanges to retain ashes and to reinforce the firebox from heat warpage.
- All welded cooking grate construction: fabricated using 5/8" dia. steel bars for support handles, and 1/2" dia. steel bars for the cooking surface; permanently incorporated into the firebox and cannot be removed; finished with high temp non-toxic black enamel paint; handle grips are 1/8" x 1/2" coiled steel bar. All grate bars are welded on both sides.
- **Optional:** Series S3 bolt on utility shelf for all N Series grills.
- **Optional:** Model N-20 and N-24 can be hot dip galvanized to include the firebox and post (example: **Model N/G-20 B2G**).
- **Optional:** Model N-20 painted grill, N/G-20 galvanized grill, and NS-20 stainless steel grill can be equipped with a stainless steel cooking grate (example: N/S-20, N/G/S-20, NS/S-20).
- **Optional:** Model N-20 grill can be built to incorporate a hot plate measuring 8" x 15". This replaces the grate bars in that portion of the total grate (becomes Model N-20/HP).
- **Optional:** Hinged steel grill cover on Model N-20 and N-24 (painted or galvanized finish). The galvanized cover can be used on the NS-20 stainless steel grill. Model S3 shelf cannot be used with cover.
- **Optional:** All standard B2 base posts can be replaced with a portable disc base (B4) or a bolt down base plate (B3).
- **Optional:** Swivel shelf Model S6 installs on 3-1/2" OD base post on models N-20, N/G-20, N-24, and N/G-24. This shelf can be used with the grill cover. Available with painted finish only. See Page 100.



**Model B2** (Standard) Embedded Base

**Model B6S** for NS-20 Stainless Steel Grill



**Model B3** Surface Mount Base **Model B17/G** for NS-20 Stainless Steel Grill

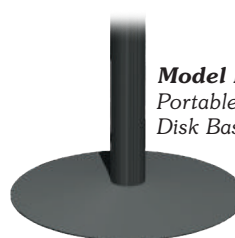

**Model B4** Portable Disk Base

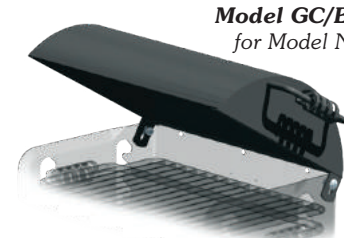

**Model GC/B** Grill Cover for Model N-20 or N-24

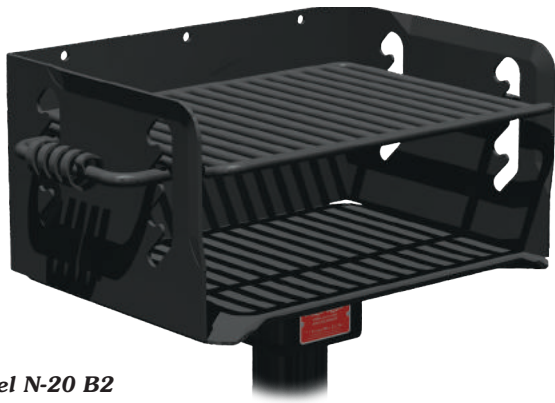

**Model N-20 B2**

Firebox Dimensions (D x W x H) . . . . . 15" x 20" x 10"  
 Cooking Area (Sq. In.) . . . . . 300  
 Finish . . . . . High-temp Enamel  
 Grate Options . . . . . (N/S) Stainless Steel, or (/HP) Hot Plate  
 Vertical Grate Adjustment from Bottom  
 of Firebox . . . . . 3-1/2", 5-1/4", 7", and 8-3/4"  
 Weight . . . . . 80 lbs.  
 Optional Shelf . . . . . (1) S3, (1) S6  
 Optional Grill Cover (S3 Shelf can not be used) . . (1) GC/B-1  
 or Galvanized Grill Cover . . . . . (1) GC/G-1  
 Base Options . . . . . B2 (Standard), B3, B4



**Model N/G-20/SG B2G**  
with optional shelf

Firebox Dimensions (D x W x H) . . . . . 15" x 20" x 10"  
 Cooking Area (Sq. In.) . . . . . 300  
 Finish . . . . . (Firebox and B2 Post) Hot Dip Galvanized  
 Grate Options . . . . . (N/G/S) Stainless Steel, or (/HP) Hot Plate  
 Vertical Grate Adjustment from Bottom  
 of Firebox . . . . . 3-1/2", 5-1/4", 7", and 8-3/4"  
 Weight . . . . . 81 lbs.  
 Optional Shelf . . . . . (1) S3/G (Hot-dip Galvanized), (1) S6  
 Optional Galvanized Grill Cover . . . . . (1) GC/G-1  
 Base Options . . . . . B2G (Standard), B3, B4



**Model NS-20/S B6S**  
with optional shelf

Firebox Dimensions (D x W x H) . . . . . 15" x 20" x 10"  
 Cooking Area (Sq. In.) . . . . . 300  
 Finish . . . . . (Firebox and Post) Stainless Steel  
 Grate Options . . . . . (NS/S) Stainless Steel  
 Vertical Grate Adjustment from Bottom  
 of Firebox . . . . . 3-1/2", 5-1/4", 7", and 8-3/4"  
 Weight . . . . . 63 lbs.  
 Optional Shelf . . . . . S3S (Stainless Steel)  
 Optional Galvanized Grill Cover . . . . . (1) GC/G-1  
 Base Options . . . . . B6S (Standard), B17/G



**Model N-24 B2**

Firebox Dimensions (D x W x H) . . . . . 18" x 24" x 10"  
 Cooking Area (Sq. In.) . . . . . 432  
 Finish . . . . . High-temp Enamel  
 Optional Finish . . . . . (Firebox and B2 Post) Hot Dip Galvanized  
 Grate Options . . . . . None  
 Vertical Grate Adjustment from Bottom  
 of Firebox . . . . . 3-1/2", 5-1/4", 7", and 8-3/4"  
 Weight . . . . . 108 lbs.  
 Optional Shelf . . . . . (1) S3, (1) S6  
 Optional Grill Cover (S3 Shelf can not be used) . . (1) GC/B-2  
 or Galvanized Grill Cover . . . . . (1) GC/G-2  
 Base Options . . . . . B2 (Standard), B3, B4

**/HP Option**  
Hot Plate Grate

Stainless Steel Grate on N-20,  
NS-20, and N/G-20 Grills

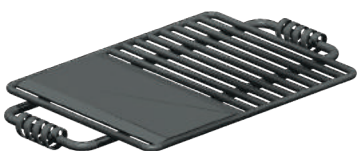

**Model S6**  
Black Enamel  
Swivel Shelf



**Model S3**  
Black Enamel Shelf  
7" x 20"

**Model S3/G**  
Hot Dip  
Galvanized Shelf

**Model S3S**  
Stainless Steel Shelf



**Model Q-20/S B2** Grill with tip-up grate and optional S3 shelf

## MultiLevel Grills — Q Series

- Two sizes: **Model Q-20** provides 300 sq. in., and **Model Q-24** provides 432 sq. in. of cooking area. Cook grate adjusts to four levels and tips up for easy fire building and clean up.
- Full 360 degree rotation in either direction on theft-proof swivel attachment. Standard 3-1/2" OD x 40" long base post for embedded installation (B2).
- All welded firebox construction includes 3/16" (7 ga.) thick steel, plus integral die-formed flanges to retain ashes and reinforce firebox from heat.
- All welded cooking grate construction: 5/8" dia. steel bars for support handles, 1/2" dia. steel bars for cooking surface. All grate bars are welded on both sides. Grate is permanently incorporated into firebox and cannot be removed. Grate tips up. Handle grips are 1/8" x 1/2" coiled steel bar.
- All components are finished with high temp non toxic black enamel paint.
- **Optional:** Model Q-20 and Q-24 can be hot dip galvanized to include the firebox and post (example **Model Q/G-20 B2G**).
- **Optional:** Model Q-20 painted grill and Q/G-20 galvanized grill can be equipped with a stainless steel cooking grate (example: Q/S-20, Q/G/S-20).
- **Optional:** Model S3 bolt on shelf, or Model S3G galvanized shelf.
- **Optional:** Model S6 swivel shelf installs on 3-1/2" OD base post. This shelf can be used with grill cover. Painted finish only. See Page 100.
- **Optional:** Hinged grill cover on Model Q-20 or Model Q-24 (painted finish) or Q/G-20 and Q/G-24 (galvanized finish). Note: Model S3 bolt on shelf cannot be used with grill cover.

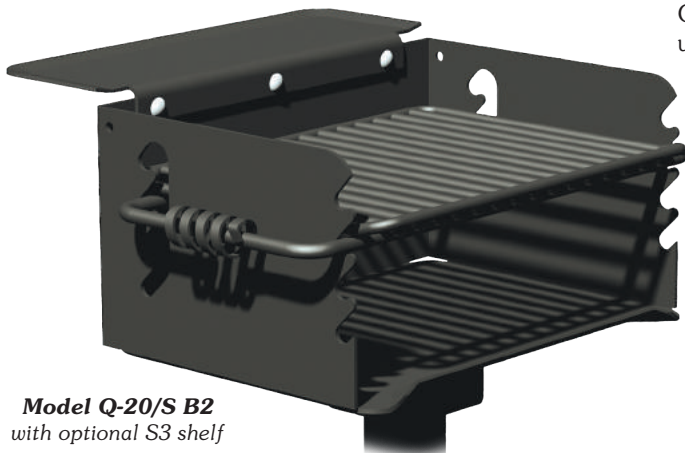

**Model Q-20/S B2**  
with optional S3 shelf

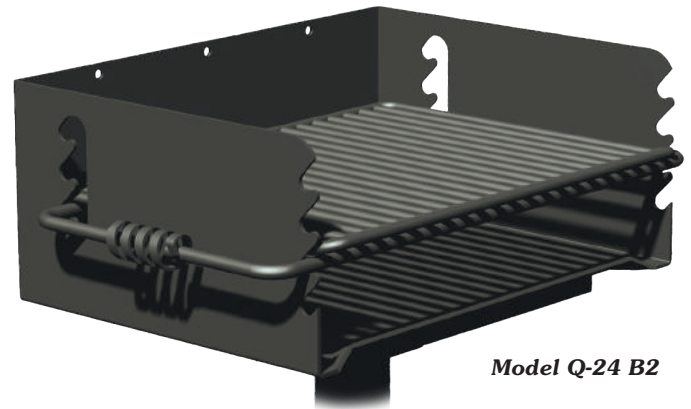

**Model Q-24 B2**

Firebox Dimensions (D x W x H) . . . . . 15" x 20" x 10"  
 Cooking Area (Sq. In.) . . . . . 300  
 Finish . . . . . High-temp Enamel  
 Optional Finish . . . (Firebox and B2 Post) Hot Dip Galvanized  
 Grate Options . . . . . (Q/S or Q/G/S) Stainless Steel  
 Vertical Grate Adjustment from Bottom  
 of Firebox . . . . . 3-1/2", 5-1/4", 7", and 8-3/4"  
 Weight . . . . . 80 lbs.  
 Optional Shelf . . . . . (1) S3, (1) S6  
 Optional Grill Cover (S3 Shelf can't be used) . . . . (1) GC/B-1  
 Optional Galvanized Grill Cover . . . . . (1) GC/G-1  
 Base Options . . . . . B2 (Standard), B3, B4

Firebox Dimensions (D x W x H) . . . . . 18" x 24" x 10"  
 Cooking Area (Sq. In.) . . . . . 432  
 Finish . . . . . High-temp Enamel  
 Optional Finish . . . (Firebox and B2 Post) Hot Dip Galvanized  
 Vertical Grate Adjustment from Bottom  
 of Firebox . . . . . 3-1/2", 5-1/4", 7", and 8-3/4"  
 Weight . . . . . 108 lbs.  
 Optional Shelf . . . . . (1) S3, (1) S6  
 Optional Grill Cover (S3 Shelf can't be used) . . . . (1) GC/B-2  
 Optional Galvanized Grill Cover . . . . . (1) GC/G-2  
 Base Options . . . . . B2 (Standard), B3, B4



**Model B2**  
(Standard)  
Embedded  
Base

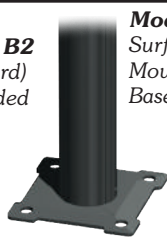

**Model B3**  
Surface  
Mount  
Base

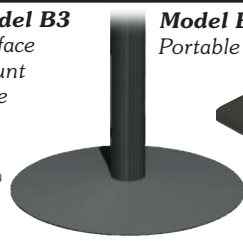

**Model B4**  
Portable Disk  
Base

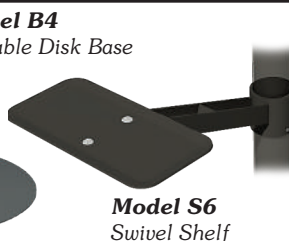

**Model S6**  
Swivel Shelf



**Model S3/G**  
Hot Dip Galvanized Shelf



**Model GC**  
Grill Cover for Model Q

**Double MultiLevel Grill - N2-2032 Series** New!

- **Model N2-2032** charcoal grill provides a total of 600 sq. inches of cooking area on twin 300 sq. in. four level adjustable back-to-back cooking grates.
- Use one or both fireboxes, depending on the size of your group. Build different size coal fires depending on your menu. Each grate can be adjusted independently.
- All-welded grill firebox construction. The N2-2032 firebox is fabricated from 3/16" (7 ga.) thick steel, with integral die-formed flanges to retain ashes and to reinforce the firebox from heat warpage, plus a reinforcement ring under the entire firebox for additional strength.
- All welded cooking grate construction. The cooking grates are fabricated using 5/8" dia. steel bars for support handles, and 1/2" dia. steel bars for the cooking surface. All grate bars are welded on both sides. The cooking grate is permanently incorporated into each firebox and cannot be removed. Grate handle grips are 1/8" x 1/2" coiled steel bar.
- The firebox is securely attached to the base post with our theft proof swivel mechanism providing continuous 360-degree rotation in either direction. The standard B2 embedded installation base post is 3-1/2" OD x 40" steel pipe.
- **OPTIONAL:** The standard B2 embedded base post can be replaced with B4 portable disc base, or B3 surface/bolt down base plate (anchor bolts are not included - use #ANC1-4 Concrete Anchor Kit), or B14 portable caster base.
- **OPTIONAL:** (1) or (2) Model S1 (7" x 9-5/8") bolt on side utility shelf, attached at the top/center of the firebox on one or both sides.
- **OPTIONAL:** (1) Model S2 (9" x 20") bolt on side utility shelf, attaches to reinforcement ring under firebox on one side only.
- **OPTIONAL:** Model N2-2032 can be equipped with twin stainless steel cooking grates (becomes Model N2/SS-2032).



**Model N2-2032 B2** Grill with two cooking grates and two optional S1 shelves. Order shelves separately.

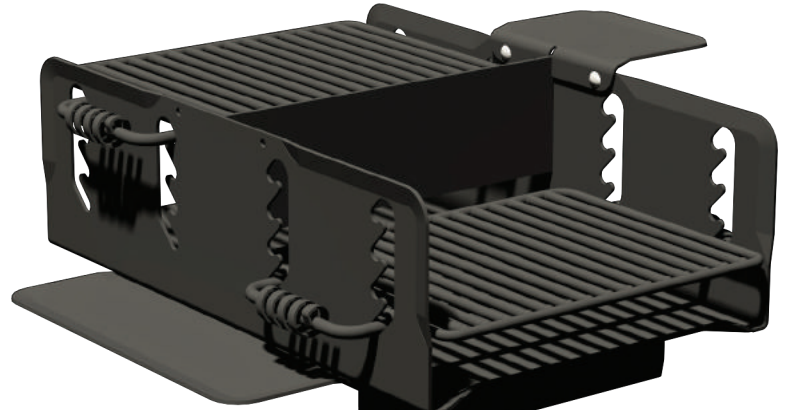

**Model N2-2032 B2** with optional S1 and S2 shelves. Order shelves separately.



**Model N2-2032 B2** Grill with two cooking grates and two optional S1 shelves. Order shelves separately.

Firebox Dimensions (D x W x H) . . . . . (2) 15" x 20" x 10"  
 Cooking Area (Sq. In.) . . . . . 600  
 No. of Grates . . . . . 2  
 Grate Options . . . . . (N2/SS) Stainless Steel  
 Vertical Grate Adjustment  
 from Bottom of Firebox . . . 3-1/2", 5-1/4", 7", and 8-3/4"  
 Weight . . . . . 141 lbs.  
 Optional Shelf (order separately) . . . . . (1 or 2) S1, (1) S2  
 Base Options . . . . . B2 (Standard), B3, B4, B14



**Model B2**  
(Standard)  
Embedded  
Base

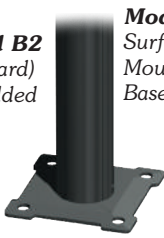

**Model B3**  
Surface  
Mount  
Base

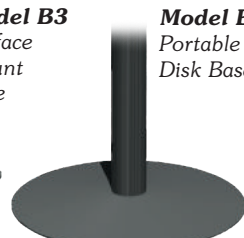

**Model B4**  
Portable  
Disk Base



**Model S1**  
7-1/8" x 9-5/8"  
Shelf



**Model S2**  
9" x 20" Shelf



Stainless Steel Grate



**Model H-16 B6** multilevel grill.

- Cooking grate adjusts to 4 levels plus tips up for easy fire building and clean out. Grate stays permanently attached to firebox.
- Grill rotates 360 degrees in either direction on theft-proof swivel attachment to post. Model H stands on a 2-3/8" OD post (B6). Models J and K use a 3-1/2" OD post (B2).
- Welded construction: 3/16" thick (7 ga.) steel firebox with die-formed reinforcing flanges; 5/8" dia. steel perimeter and handle bars, 1/2" dia. grate bars. All grate bars are welded on both sides. High temp non-toxic black enamel paint finish.
- Side indentations support the grate in 4 locations and minimize side openings for superior draft protection. Coiled 1/8" x 1/2" steel bar handle grips for convenient grate adjustment.
- **Optional:** Model S3 bolt-on shelf on K-20 grill. Or Model S6 swivel shelf mounts on 3-1/2" OD base post on J-20 and K-20 grills.
- **Optional:** Model K-20 can be equipped with hinged grill cover.
- **Optional:** Model J-20 and K-20 can include 8" x 15" Hot Plate, replacing a portion of the bars in the cooking grate (e.g. becomes Model J-20/HP).



**Model H-16 B6**

Firebox Dimensions (D x W x H)	16" x 16" x 8"
Cooking Area (Sq. In.)	250
Vertical Grate Adjustment from Bottom of Firebox	2-1/2" to 7-3/4"
Weight	.61 lbs.
Optional Shelf	None
Base Options	B6 (Standard), B17

## MultiLevel Grills — H, J, or K Series

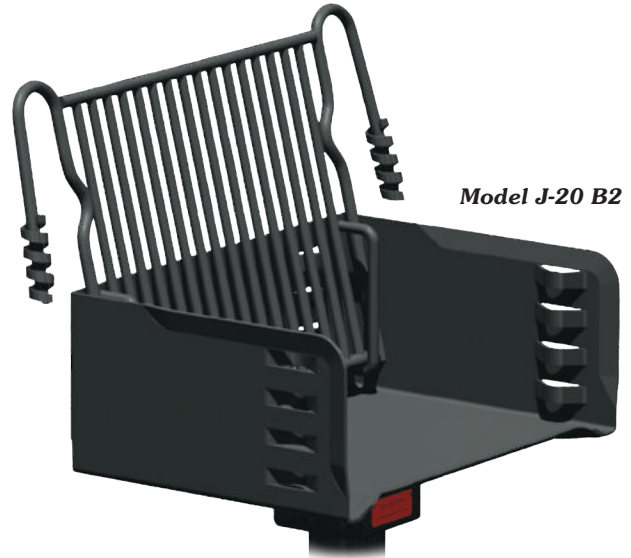

**Model J-20 B2**

Firebox Dimensions (D x W x H)	15" x 20" x 8"
Cooking Area (Sq. In.)	300
Vertical Grate Adjustment from Bottom of Firebox	2-1/2" to 7-3/4"
Weight	.75 lbs.
Optional Shelf	S6
Base Options	B2 (Standard), B3, B4, B6

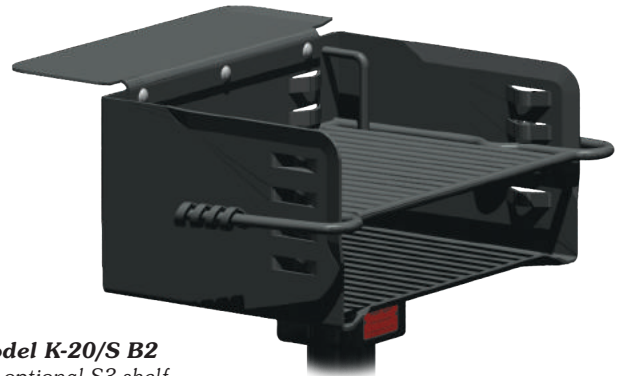

**Model K-20/S B2**  
with optional S3 shelf

Firebox Dimensions (D x W x H)	15" x 20" x 10"
Cooking Area (Sq. In.)	300
Vertical Grate Adjustment from Bottom of Firebox	4" to 9-1/4"
Weight	.83 lbs.
Optional Shelf	(1) S3, (1) S6
Optional Grill Cover (S3 Shelf can't be used)	(1) GC/B-1
Base Options	B2 (Standard), B3, B4



**Models B2 or B6**  
Embedded Base

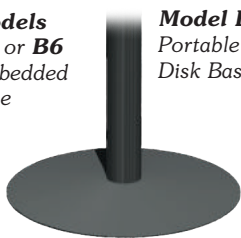

**Model B4**  
Portable Disk Base



**Model B3 or B17**  
Surface Mount Base



**Model GC/B-1** Grill Cover  
for Model K-20 grill only



**Model S6**  
Swivel Shelf



**Model S3**  
7" x 20" Shelf



Covered Grills — EC Series



(Above)  
**Model EC-40/S B2**  
covered grill with  
utility shelf and optional  
warming basket.  
(Left)  
**Model EC-26/S B2**,  
cover closed, showing  
handles, draft vents and  
clean out door.



**Model EC-26/S B2**  
with optional  
warming basket



**Model EC-40/S B2**  
with optional  
warming basket

Overall Dimensions without shelf (D x W x H)  
..... 19-1/2" x 29-1/4" x 16-1/2"

Cooking Area (Sq. In.) ..... 320

No. of Grates ..... (1) Cooking, (1) Fire

Weight ..... 144 lbs.

Optional Shelf ..... (1) S6

Base Options ..... B2 (Standard), B3, B4, B12

Warming Basket (7" x 21" x 2") ..... ECB-26

Overall Dimensions without shelf (D x W x H)  
..... 19-1/2" x 41-1/2" x 16-1/2"

Cooking Area (Sq. In.) ..... 500

No. of Grates ..... (1) Cooking, (1) Fire

Weight ..... 187 lbs.

Optional Shelf ..... None

Base Options ..... B2 (Standard), B3, B4, B12

Warming Basket (7" x 33" x 2") ..... ECB-40



**Model B2**  
Embedded  
Base

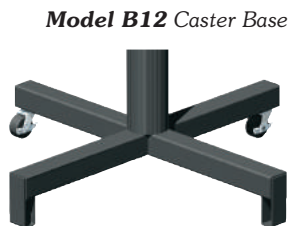

**Model B12** Caster Base



**Model B3**  
Surface  
Mount Base

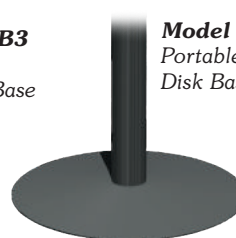

**Model B4**  
Portable  
Disk Base



**Model S2**  
9" x 20"  
Shelf (included)

- Covered Grills hold in smoke and heat. Covers also keep rain and snow out of firebox to prolong life of grill.
- Single level cooking grate is hinged to tip up for easy access to fire grate. Fire grate keeps coals off bottom of firebox. This provides better draft control and prolongs life of grill. The fire grate also tips up for easy ash clean out through side door.
- Four adjustable draft vents control fire and cooking rate. Full contact rear edge between bottom and cover provides draft control when lid is open. Continuous 360-degree rotation in either direction is provided on theft-proof swivel attachment to 3-1/2" OD x 40" long base post (B2) for embedded installation.
- Both firebox and cover have a 1" formed flange to provide flat, stable contact perimeter and to substantially reinforce grill halves. Slotted steel hinges allow cover to adjust to an obstruction, eliminating potential pinch points. Once fully open the cover is locked in place and cannot be closed without deliberate user action. Cover and grate handle grips are 1/8" x 1/2" coiled steel bar.
- All-welded construction. Heavy gauge steel is used for cover (14 ga.), bottom (10 ga.) and end panels (11 ga.). Cooking and fire grates are created using 1/2" dia. steel bar, with 5/8" dia. handle bars. All grate bars are welded on both sides. Unit is finished with high temp non-toxic black enamel paint.
- Each grill includes one Model S2 bolt-on utility shelf.
- **Optional:** Model S6 swivel shelf available on EC-26 only. See Page 100.
- **Optional:** Portable, bolt down or caster bases.
- **Optional:** Warming Basket to hang inside top cover. See Page 100.



Model Q3-2460 B8 shelterhouse grill with standard surface mount base.

## Large Group Grill — Q3-2460 Series



Model Q3-2460 B8

- **Model Q3-2460 B8** group grill provides 1220 total sq. inches of cooking area on 3 grate surfaces.
- Firebox measures 24" x 60" x 10" high sides, constructed of 3/16" thick steel plate, rib reinforced to prevent box warpage.
- Cooking grate adjusts to 4 levels above the fire, is not removable from the firebox, includes dual protective coiled steel bar handle grips at both ends. Grate tips up for easy fire building and cleaning.
- Cooking grate is constructed of 5/8" dia. handle bars and 1/2" dia. grate bars. All grate bars are welded on both sides. Includes 1" wide steel full-length support brace under front edge of grate to prevent deformation.
- Total grate area is divided into three cooking chambers and is supported by four 3/16" thick steel panels.
- Base post is 6" OD heavy wall steel pipe with a 3/8" x 10" square base plate for surface installation. Four 1/2" x 6" J-bolt anchors for concrete footing are included.
- Continuous 360 degree rotation on theft proof swivel attachment.
- Finished with high temp non toxic black enamel paint.
- **Optional:** Embedded base post to replace bolt down base plate.
- **Optional:** Model S7 bolt on shelf, 7 ga. steel, 10-5/8" x 59".

Firebox Dimensions (D x W x H)	24" x 60" x 10"
Cooking Area (Sq. In.)	1220
No. of Grates	(3) Cooking
Vertical Grate Adjustment from Bottom of Firebox	3-1/2", 5-1/4", 7", and 8-3/4"
Weight	289 lbs.
Optional Shelf	S7
Base Options	B8 (Standard), B16



Model B16  
Embedded  
Base

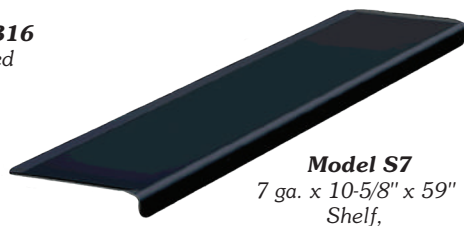

Model S7  
7 ga. x 10-5/8" x 59"  
Shelf,



Model GGS/B-1  
Grill & Grate Scraper.

Model HCB-1  
Hot Coal Bin



Large Group Grills — P or L Series



- **Model P-1000** offers 1008 sq. in. on twin 4-level adjustable cooking grates.
- **Model L-1500** offers 1350 sq. in. on twin single-level hinged cooking grates with a fire grate that adjusts to 4 levels under them.

(Left) **Model P-1000/S B7** shelterhouse grill.

(Below) **Model L-1500/SS B8** shelterhouse grill.



- Continuous 360-degree rotation on theft-proof swivel attachments. Model P-1000 stands on a 4-1/2" OD post; Model L-1500 stands on a 6" OD post. Both grills feature a 10" sq. bolt down plate installation onto a concrete surface. Four 1/2" x 6" J-bolt anchors included.
- Both Models include (1) bolt on 10-5/8" x 36" steel utility shelf. Both grills have additional optional shelves.
- Welded construction: 3/16" thick (7 ga.) steel firebox with die-formed reinforcing flanges, substantial gusseted bracing and ring reinforcement to help dissipate heat. Grates use 5/8" dia. steel perimeter and handle bars, and 1/2" dia. grate bars. All grate bars are welded on both sides. Entire grill is finished with high temp non-toxic black enamel paint.
- **Optional:** Portable caster base or embedded base to replace bolt down base plate.

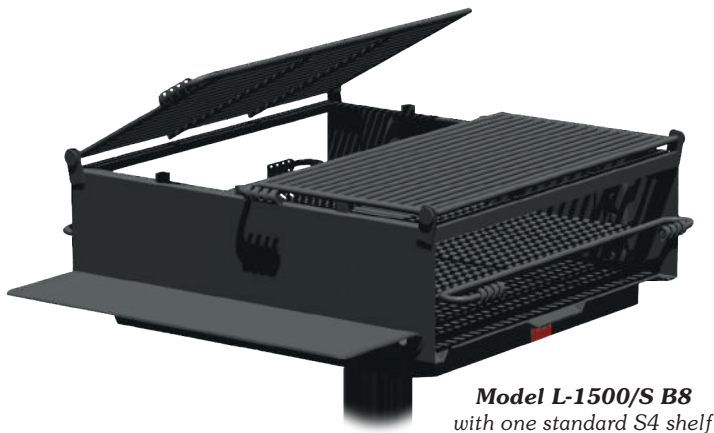

**Model L-1500/S B8**  
with one standard S4 shelf

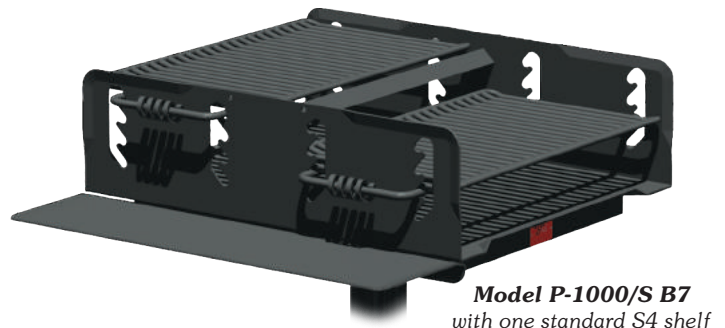

**Model P-1000/S B7**  
with one standard S4 shelf

Firebox Dimensions (D x W x H) . . . . . 36" x 38" x 12"  
 Cooking Area (Sq. In.) . . . . . 1350  
 No. of Grates . . . . . (1) Fire, (2) Cooking  
 Fire Grate Vertical Grate Adjustment  
 from Bottom of Cooking Grate . . . . . 4-15/16" to 10"  
 Weight . . . . . 430 lbs.  
 Optional Shelves . . . . . (1) S4 (Included), (1) Additional S4  
 Base Options . . . . . B8 (Standard), B11, B16

Firebox Dimensions (D x W x H) . . . . . 28" x 36" x 10"  
 Cooking Area (Sq. In.) . . . . . 1008  
 No. of Grates . . . . . 2  
 Vertical Grate Adjustment  
 from Bottom of Firebox . . . . . 3-3/4" to 9"  
 Weight . . . . . 215 lbs.  
 Optional Shelves  
 . . . . . (1) S4 (Included), (1 or 2) S1, (1) Additional S4  
 Base Options . . . . . B7 (Standard), B13, B15

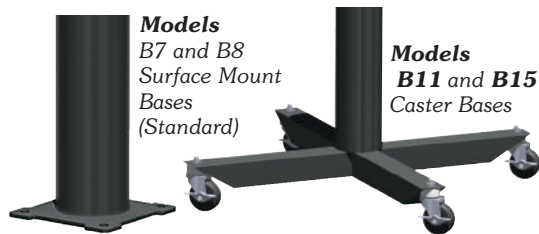

**Models B7 and B8**  
Surface Mount  
Bases  
(Standard)

**Models B11 and B15**  
Caster Bases



**Model B13 and B16**  
Embedded  
Base



**Model S1**  
7-1/8" x 9-5/8" Shelf



**Model S4**  
10-5/8" x 36"  
Shelf

## Grill Station — Your Grill and Work Table All In One



Model GS/CB-5PC Grill Station with black powder coated frame, cedar colored recycled plastic planks and optional Model Q-20-2 park grill.

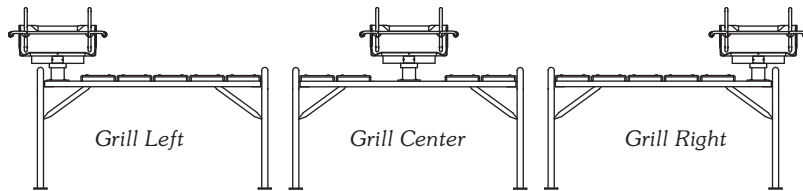

Your choice of grill can be installed at either end or in the center of the Grill Station.

- The Grill Station combines a Pilot Rock charcoal grill with a work table. No need for separate installations of a grill on a post and a utility table. Now it's all in one!

**Model GS-5 Grill Station** features include:

- **Rugged Construction:** 1-5/8" OD steel pipe end frames with welded-on brace and top frame bracket. Diagonal braces ensure a rigid, stable structure. Top frame is 1-1/2" Steel angle, welded into single component.
- **Frame Finish:** Hot dip galvanized is standard. Colorful powder coat paint is optional. See Page 47.
- **Table Top:** Built with (5) 2" x 10" (nom.) x 20" wide planks, plus (1) grill mount plate. Available table top materials include: untreated or treated pine, colorful recycled plastic, and clear anodized or powder coated aluminum. See Page 48, 50.
- **Footprint:** Grill Station is 22-1/2" by 64" (nom.) overall outside dimensions (does not include grill).
- **Work Space:** 20" wide by 48" long (when grill is at one end).
- **Work Height:** Table height = 30-1/2"; Grill height = 36" to bottom of firebox (charcoals). Cooking grate height will vary depending on grill model chosen.
- **Grill Mount:** The grill can be installed at either end or in the center. (Note: a center location will reduce table top space to 2 planks per side.) The theft proof swivel attachment allows the grill to rotate 360 degrees for maximum cooking control.
- **Installation:** Surface mount flanges on each frame leg. Anchor bolt kit #ANC3-4 for a concrete surface is included.
- **Grill Choices:** The Pilot Rock charcoal grill is sold separately. See Chart below.

GRILL CHOICES FOR MODEL GS-5 GRILL STATION						Model	Cooking Area	Catalog Page
Model	Cooking Area	Catalog Page	Model	Cooking Area	Catalog Page	ASW-20-2	300	89
A-20-2	320	90	J-20-2	300	96	N-24-2	432	92
B-24-2	384	90	K-20-2	300	96	Q-20-2	300	94
EC-26/S-2	320	97	N-20-2	300	92	Q-24-2	432	94

## Swivel Shelf

- **Model S6 Swivel Shelf** (8" x 16") option for Model EC-26 Covered Grill installs on the 3-1/2" OD base post (must be installed prior to firebox and locking pin). The shelf will swivel 360 degrees around the post, independently of the grill firebox. Finished with black enamel paint. (This option is not available on EC-40 Grills.)



- Model S6 Swivel Shelf will fit on the following Pilot Rock Grills: ASW-20, A-20, B-24, N-20 (shown at left), N-24, Q-20, Q-24, J-20, K-20, and EC-26 (shown at right).

## Warming Basket

- The Warming Basket option for EC Covered Grills gives you a place to keep some foods warm while grilling other foods on the cooking grate. The expanded steel Basket is suspended from hinges inside the top cover and will rotate to remain level as the cover is opened/closed. The Warming Basket option is available on all EC Grills manufactured after 4/1/2007.

- **Model ECB-26** Warming Basket (7" x 21" x 2" deep) fits Model EC-26 Grills.
- **Model ECB-40** Warming Basket (7" x 33" x 2" deep) fits Model EC-40 Grills.





**Model HCB/B-1**  
Hot Coal Bin  
for coal  
and ash disposal.



**Model HCB/B-1** Hot Coal Bin  
with black high temp enamel top.  
Shown with door open to show  
optional garbage can.

## Hot Coal Disposal Bin

- **Model HCB/B-1** Hot Coal Bin is a convenient, economical, safe way to dispose of hot coals and ashes from grills, and help prevent the dumping of hot coals on the ground.
- The 23" square top funnels down to a 12" square grated opening. The grate bar spacings will allow full size charcoal briquettes through, but will restrict most large trash. A full-length piano hinge attaches the door to one side panel. The draw-pull door latch can be padlocked to keep other trash and vandals out.
- Inside place any size steel container up to a 32-gallon capacity garbage can.
- **OR:** Anchor Bin to a concrete pad. The ashes collect on the concrete pad inside the Bin. To clean out, open the door and scoop out the ashes with a flat shovel.
- The Hot Coal Bin also serves as a convenient depository for park maintenance personnel to dump ashes as they clean out pedestal grills. Picnickers can also use it when done grilling.
- Two anchor methods: Order optional Model M9/B ground anchor stakes to secure the Bin on top of the ground (this requires a steel collection can inside); or for anchoring Bin to concrete surface order Model BR-4HSA anchors.
- **Features:** Bin measures 23" x 23" x 32-1/2" tall, fabricated from 1/16" (14 ga.) steel for the side panels and top funnel, 1/2" dia. steel bars for the grate, **high temp black enamel paint**, includes (2) "caution" decals, ships unassembled, galvanized fasteners included.
- **Optional:** Powder coat paint finish on side panels and door (not high heat). See Page 47.
- **Optional:** See available options below.



**Model HCB/CR-1**  
Hot Coal Bin with  
optional red powder  
coat paint finish  
(not high heat).



**Model PL-1**  
Brass  
Padlock



**Model CNG-2310C**  
31 gallon  
galvanized  
steel can



**Model M9/B** Ground  
Anchors, set of (3).

**Model BR-4HSA** set of (4)  
3/8" x 1-7/8" hex sleeve  
concrete anchors (not  
shown).



**Model GGS/B-1**  
Grill & Grate Scraper.



**Model CNG-W10120**  
12 quart  
galvanized steel  
collection pail

## Options for Grills



Embedded



Surface Mount



Portable, Four Casters



Portable, Two Casters, Two Pads

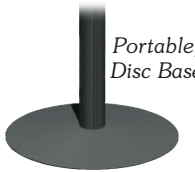

Portable, Disc Base



Bolt-on



Swivel, Mounts on Base Post, must be installed before grill



Grill Bases				
Model	O.D. and Length	Style	Finish	Use with these grills
B2	3-1/2" x 40"	Embedded	Black Enamel Paint	Standard on A-20, B-24, C2-36, D2-48, N-20, N-24, Q-20, Q-24, J-20, K-20, EC-26, EC-40, ASW-20, N2-2032
B2G	3-1/2" x 40"	Embedded	Hot Dip Galvanized	Standard on N/G-20, N/G-24
B6	2-3/8" x 40"	Embedded	Black Enamel Paint	Standard on H-16
B6S	2-3/8" x 40"	Embedded	Stainless Steel	Standard on NS-20, NS/S-20
B13	4-1/2" x 40"	Embedded	Black Enamel Paint	P-1000
B16	6" x 40"	Embedded	Black Enamel Paint	Q3-2460, L-1500
B3	3-1/2" x 26-7/8"	Surface Mount 1/4" x 8" x 8" Plate	Black Enamel Paint	A-20, B-24, C2-36, D2-48, N-20, N-24, N/G-20, N/G-24, N2-2032, Q-20, Q-24, Q/G-20, Q/G-24, J-20, K-20, EC-26, EC-40
B17	2-3/8" x 26-7/8"	Surface Mount 1/4" x 8" x 8" Plate	Black Enamel Paint	H-16
B17/G	2-3/8" x 26-7/8"	Surface Mount 1/4" x 8" x 8" Plate	Hot Dip Galvanized	NS-20, NS/S-20
B7	4-1/2" x 27"	Surface Mount 3/8" x 10" x 10" Plate	Black Enamel Paint	Standard on P-1000
B8	6" x 27"	Surface Mount 3/8" x 10" x 10" Plate	Black Enamel Paint	Standard on Q3-2460, L-1500
B18	3-1/2" x 24-3/8"	Surface Mount 1/4" x 8" x 8" Plate	Black Enamel Paint	ASW-20
B11	6" x 28-9/16"	Portable, Four Casters	Black Enamel Paint	L-1500
B12	3-1/2" x 28-1/2"	Portable, Two Casters, two Pads	Black Enamel Paint	EC-26, EC-40
B14	3-1/2" x 28-9/16"	Portable, Four Casters	Black Enamel Paint	C2-36, D2-48, N2-2032
B15	4-1/2" x 28-9/16"	Portable, Four Casters	Black Enamel Paint	P-1000
B4	3-1/2" x 25-11/16"	Portable, Disc	Black Enamel Paint	A-20, B-24, C2-36, D2-48, N-20, N-24, N/G-20, N/G-24, N2-2032, Q-20, Q-24, Q/G-20, Q/G-24, J-20, K-20, EC-26, EC-40

Grill Shelves				
Model	Dimensions	Style	Finish	Use with these grills
S1	7-1/8" x 9-5/8"	Bolt-on	Black Enamel Paint	A-20, B-24, C2-36, P-1000, N2-2032
S2	9" x 20"	Bolt-on	Black Enamel Paint	D2-48, Included on EC-26 & EC-40, N2-2032
S3	7" x 20"	Bolt-on	Black Enamel Paint	N-20, N-24, Q-20, Q-24, K-20
S3/G	7" x 20"	Bolt-on	Hot Dip Galvanized	N/G-20
S3S	7" x 20"	Bolt-on	Stainless Steel	NS-20, NS/S-20
S4	12" x 36"	Bolt-on	Black Enamel Paint	(1 Included, 1 Optional) L-1500 & P-1000
S6	8" x 16"	Swivel Mount on base Post (Install before grill)	Black Enamel Paint	A-20, B-24, N-20, N/G-20, N-24, N/G-24, Q-20, Q/G-20, Q-24, Q/G-24 J-20, K-20, EC-26, ASW-20
S7	10-5/8" x 59"	Bolt-on	Black Enamel Paint	Q3-2460

Grill Covers	
Model	Use with these grills
GC/B-1	N-20, Q-20, K-20
GC/G-1	N-20, N/G-20, NS-20, Q-20, Q/G-20
GC/B-2	N-24, Q-24
GC/G-2	N-24, N/G-24, Q-24, Q/G-24

Hot Plate Grate, /HP

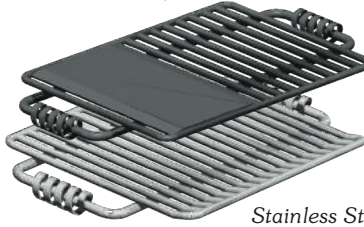

Stainless Steel Grate, /S

Optional Cooking Grates	
Model	Use with these grills
/HP	N-20, N/G-20, J-20, K-20
/S	N-20, N/G-20, NS-20, Q-20, Q/G-20, N2-2032

**Campfire Ring Only – No Grate** New!

- When you need the fire barrier only, without the cooking grate.
- Our **FX Series** Campfire Rings provide a solid steel fire barrier, and do not include the cooking grate.
- Perfect when you don't plan to cook over the fire, but you need the barrier to control the fire and protect the property or your landscape blocks.
- The steel ring is rolled from 3/16" thick steel plate with an integral formed 1" wide flange around the top edge. This flange provides extra strength against heat warpage and eliminates a vertical edge. Draft holes are provided for fire ventilation.
- FX Series Campfire Rings are available in 4 different diameters and 4 different side heights (see chart below for dimensions). Select the diameter to control the fire size, and the side height to achieve the degree of fire barrier needed.
- All FX Series firerings come with anchors. Tip back anchor pins (TB) available on some models keep the ring secured in one place, but allow the ring to tip up for easy clean out. Other stationary anchor systems include angle legs (AL) and pin anchors (PA) keep the ring securely on the ground. See Page 112. Refer to the chart below to see which anchor method is available on each firering.
- **OPTIONAL:** Bolt on utility shelf Model S5. See Page 111.
- **OPTIONAL:** Removable Drop-In Grate Model DIG-U1. See Page 110.
- **OPTIONAL:** Snuffer Cover protects firering from the elements and suffocates fires. See Page 110.



*Model FX-30/11/TB campfire ring in it's simplest form, with no grate.*



*Model FX-30/11/TB campfire ring with optional Model DIG-U1 Drop-in cooking grate.*



*Model FX-30/11/TB campfire ring with optional Model CFX-30 Snuffer Cover.*

Model	Inside Diameter	Side Height	Anchor System	Cooking Area (Sq. In.)
FX-26/7/TB	24"	7-3/8"	TB (Standard), AL, TA (optional). See Page 112	No Cooking Grate
FX-30/7/TB	30"	7-3/8"		
FX-30/9/TB		9"		
FX-30/11/TB		11-3/8"		
FX-48/7/PA	46"	7-3/8"	PA (Standard), AL (optional). See Page 112	
FX-48/9/PA		9"		
FX-48/11/PA		11-3/8"		
FX-56/7/PA	54"	7-3/8"		
FX-56/9/PA		9"		
FX-56/11/PA		11-3/8"		
FX-30/18/PA		30"		16-7/8"

**Enjoy the Outdoors – with a complete set of site furnishings.**

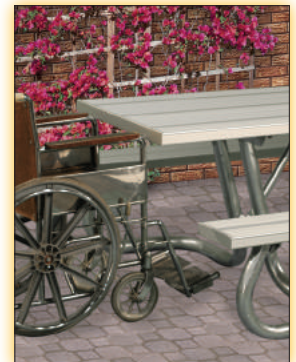

- Web Site: [www.pilotrock.com](http://www.pilotrock.com) •
- E-Mail: [pilotrock@rjthomas.com](mailto:pilotrock@rjthomas.com) •



## The Original Infinitely Adjustable Cooking Grate



(Above) **Model FA-30/7/TB** showing cooking grate being tipped over and out of firering.  
(Left) **Model FA-30/7/TB** campfire ring, 7-3/8" tall.

- **The FA Series** Campfire Rings combines our original Infinitely Adjustable cooking grate with our flanged firering – a practical design combination for campfire control and convenient outdoor cooking.
- Ring is rolled from a 3/16" thick steel plate with an integral formed 1" wide flange around top edge. This flange provides extra strength against heat warpage and eliminates a vertical edge. Draft holes are provided for fire ventilation.
- 270 sq. inch cooking grate is Infinitely Adjustable vertically from below the top of the ring to 7-3/4" higher. This cantilevered grate is structurally reinforced to resist hard use and vandalism. Two adults can stand on it without deformation.
- The cooking grate can be lifted over and out of the ring, but remains permanently attached.
- **FA Series** Campfire rings come in two different diameters and 4 different side heights (see chart below). Select the diameter to control the size of fire, and the side height to achieve the degree of fire barrier needed.



**Model FA-30/18/S** firering with optional shelf.  
(Note: anchor pins not used in this installation).

- **FA Series** firerings include tip back anchor pins (standard) to keep the ring secured, but allow the ring to tip up for easy clean out. Other anchor systems are available. See Page 112.
- Cooking grate adjustment handles, made from 3/4" dia. steel, are turned outside of the ring, away from the fire. The handle grips are 1/8" x 1/2" coiled steel bar. The cooking grate is built using 5/8" dia. steel perimeter bars and 1/2" dia. steel grate bars. All grate bars are welded on both sides.
- **Model FA-30/18** combines our Infinitely Adjustable cooking grate with a taller ring, providing a more comfortable working height. The elevated design allows placement flexibility because the aggregate fill (not included) protects existing surfaces such as pavers, asphalt and concrete. This fill also insulates the ground to reduce the chance of root fires in heavily wooded areas.
- Finished with high temp non-toxic black enamel paint.
- **Optional:** Bolt on utility shelf Model S5. See Page 111.
- **Optional:** Heat shield Model HS-F. See Page 111.

### FA Side Heights

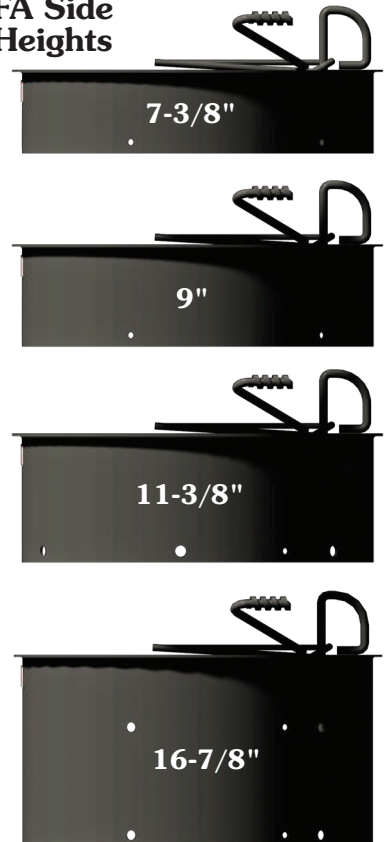

Model	Inside Diameter	Side Ht.	Anchor Systems	Cooking Area (Sq. In.)	Vertical Grate Adj, (in.)
<b>FA-26/7/TB</b>	24"	7-3/8"	TB (Standard), AL, TA (Optional) See Page 112	270	7-3/4
<b>FA-30/7/TB</b>	30"	7-3/8"			
<b>FA-30/9/TB</b>		9"			
<b>FA-30/11/TB</b>		11-3/8"			
<b>FA-30/18/PA</b>		16-7/8"	PA (Standard), AL (Optional) See Page 112		



Single Level Cooking Grate



(Above) **Model FS-48/9/PA** campfire ring, 9" tall.  
 (Left) **Model FS-30/9/TB** campfire ring, 9" tall.

- The **FS Series** Campfire Rings combine a single level cooking grate with our flanged firering – an economical design when cooking over the fire might be a lower priority.
- Ring is rolled from 3/16" thick steel plate with an integral formed 1" wide flange around top edge. This flange provides extra strength against heat warpage and eliminates a vertical edge. Draft holes are provided for fire ventilation.
- 290 sq. inch single level cooking grate is hinged to the ring and remains permanently attached.
- **FS Series** Campfire Rings are available in 4 different diameters, and up to 3 different side heights (see chart below, right). Select the diameter to control the size of fire, and the side height to achieve the degree of fire barrier needed.
- Tip back anchor pins (standard) keep the ring secured in one place, but allow the ring to tip up for easy clean out. Other anchor systems available. See Page 112.

- Cooking grate adjustment handles, made from 3/4" dia. steel, reach outside of the ring, away from the fire. The handle grips are 1/8" x 1/2" coiled steel bar. The cooking grate is built using 5/8" dia. steel perimeter bars and 1/2" dia. steel grate bars. The grate hinges are formed using 5/8" dia. steel bar. All grate bars are welded on both sides.
- Finished with high temp non-toxic black enamel paint.
- **Optional:** Bolt on utility shelf Model S5. See Page 111.
- **Optional:** Single level Swivel Grate, 300 sq. in. See Page 108. Change "FS" to "FSW" in all model numbers.



Outside diameter (at flange)

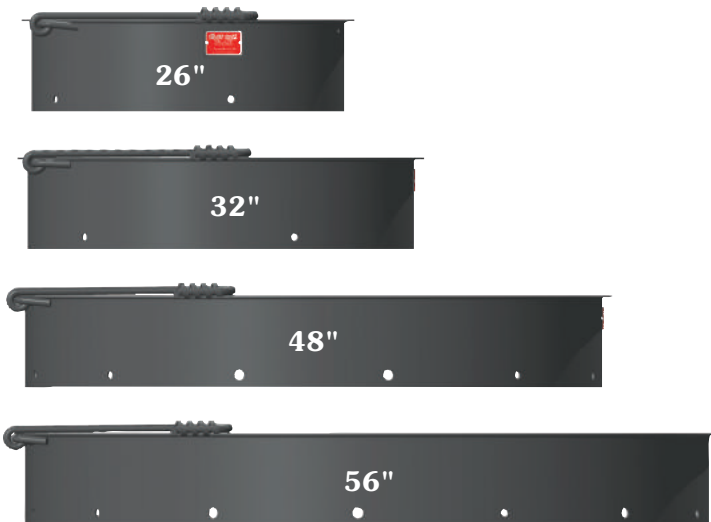

Model	Inside Diameter	Side Ht.	Anchor Systems	Cooking Area (Sq. In.)
FS-26/7/TB	24"	7-3/8"	TB (Standard), AL,TA (Optional) See Page 112	290
FS-30/7/TB	30"	7-3/8"		
FS-30/9/TB		9"		
FS-30/11/TB		11-3/8"		
FS-48/7/PA	46"	7-3/8"	PA (Standard), AL (Optional) See Page 112	290
FS-48/9/PA		9"		
FS-48/11/PA		11-3/8"		
FS-56/7/PA	54"	7-3/8"		
FS-56/9/PA		9"		
FS-56/11/PA		11-3/8"		

- Web Site: [www.pilotrock.com](http://www.pilotrock.com) •
- E-Mail: [pilotrock@rjthomas.com](mailto:pilotrock@rjthomas.com) •



**Model M-32/17** accessible firering

(Note: this installation did not require use of pin anchors).

## Multilevel Cooking Grate

- **Model M-32** accessible campfire ring features a **flat rear panel so wheelchairs can have closer access** to the cooking grate and adjustment handles. The 300 sq. inch cooking grate adjusts to 4 levels between 19" and 24" above the ground. This design allows the grate to be adjusted one side at a time, using only one hand, and does not exceed 10 lbs. to lift.
- The firering is rolled using 3/16" thick steel, with 1" formed flange for strength and safety. The adjustment panels are cut from 3/16" steel, and also serve as heat shields. The cooking grate is welded together using 5/8" dia. handle/support bars and 1/2" dia. grate bars, and includes handle grips of 1/8" x 1/2" coiled steel. All grate bars are welded on both sides. The finish is high temp non-toxic black enamel paint. Pin anchors provide a fixed location.
- The ring is filled with aggregate (not included) to about 10-1/2" deep to provide the elevated fire surface. This fill also insulates the ground to reduce the chance of root fires in heavily wooded areas. Drain/draft holes are provided around the perimeter of the ring.
- **Optional:** Bolt on utility shelf Model S5 (see Page 111).
- **Optional:** Heat shield Model HS-M (see Page 111).

Model	Inside Diameter	Side Ht.	Anchor Systems	Cooking Area (Sq. In.)
M-32/17/PA	30"	16-3/8"	PA only See Page 112	300



**Model LDW-36/18/TB**  
Double Wall Firering with  
four level adjustable grate  
and tip-back anchors.  
18" high fire barrier.



## Multilevel Grate — Double Walled

Accessible campfire ring **Model LDW-36/18/TB** includes a full-height outer ring to serve as a heat barrier for the inner ring. It also features a 300 sq. inch four level adjustable cooking grate.

- 1/8" (10 ga.) outer ring with 1" formed top flange; 3/16" (7 ga.) inner ring; 17-3/8" tall fire barrier.
- Three formed steel angles welded between rings form a 2" wide air space. Both rings include a series of 1" dia. (nom.) drain/draft holes. 3/16" thick steel panels support the cooking grate in four locations and help shield grate handles from heat.
- 300 sq. in. cooking grate is all welded 1/2" dia. steel bars supported by 5/8" dia. handle bars. 1/8" x 1/2" coiled flat steel bar handle grips. All grate bars are welded on both sides.
- Includes two tip back anchor pins to secure ring in place but allow ring to tip up for clean out (do not use aggregate fill).
- Finished with high temp non toxic black enamel paint.
- **Optional:** Bolt on utility shelf. See Page 111.
- **Optional:** Angle spade anchors (can use aggregate fill to raise the firebed). See Page 112.

Model	Inside, Outside Diameter	Side Ht.	Anchor Systems	Cooking Area (Sq. In.)
LDW-36/18/TB	31-3/4", 36-1/2"	17-3/8"	TB Standard AL (optional) See Page 112	300

## Double Walled Firering

- This accessible campfire ring offers a full-height outer ring as a heat barrier for the inner ring. 1" dia. draft holes feed air into the space between the rings. This unit does not require aggregate fill because it is equipped with a fire/log grate inside the ring. Designed to accommodate a person in a wheelchair. Tip back anchor pins secure the unit in place.
- Fabrication includes a 1/8" thick steel outer ring with the formed reinforcing flange, and a 3/16" thick steel inner ring. Both rings are 17-3/8" tall. The 370 sq. inch single level cooking grate is permanently hinged to the outer ring. Inside is the large 380 sq. inch log grate. This log grate is hinged to the inner ring and tips up to simplify ash clean out. The cooking and fire grates are fabricated using 5/8" dia. perimeter and handle bars with coiled steel bar grips, and 1/2" dia. grate bars. All grate bars are welded on both sides. The firering is finished with high temp non-toxic black enamel paint.
- **Optional:** Bolt on utility shelf Model S5. See Page 111.
- **Optional:** Swivel Grate (replaces flip-over grate). Meets ADA guidelines for operation and weight. See Page 108.



**Model FSDW-30/18/TB**  
double walled campfire ring.

Model	Inside, Outside Diameter	Side Ht.	Anchor Systems	Cooking Area (Sq. In.)	Fire Grate Area (Sq. In.)
FSDW-30/18/TB	26-3/8", 32"	17-3/8"	TB only See Page 112	370 Flip Over	380
FSWDW-30/18/TB				300 Swivel	



## Single Level Cooking Grate

- This accessible firering includes the simple single level cooking grate. The 290 sq. inch grate can be laid over the fire, or tipped over and out of the firering, but it remains permanently hinged to the ring. This taller ring, available in 18" or 24" tall designs, brings the cooking surface to a convenient height for use from a wheelchair.
- The firering is rolled using 3/16" thick steel, with 1" formed flange for strength and safety. The welded cooking grate uses a 3/4" dia. handle bar, 5/8" dia. perimeter bar and 1/2" dia. grate bars, and includes handle grips of 1/8" x 1/2" coiled steel. All grate bars are welded on both sides. Finished with high temp non toxic black enamel paint. Pin anchors provide a fixed location.
- The ring is filled with aggregate (not included) to about 9" deep to provide the elevated fire surface. This fill also insulates the ground to reduce the chance of root fires in heavily wooded areas. Drain/draft holes are provided around the perimeter of the ring.
- **Optional:** Bolt on utility shelf Model S5. See Page 111.
- **Optional:** Heat shield Model HS-F. See Page 111.
- **Optional:** Swivel Grate (replaces flip-over grate). Meets ADA guidelines for operation and weight. See Page 108.

Model	Inside Diameter	Side Ht.	Anchor Systems	Cooking Area (Sq. In.)
FS-30/18/PA	30"	16-7/8"	PA only See Page 112	290 Flip Over
FS-30/24/PA		23-3/8"		
FSW-30/18/PA		16-7/8"		300 Swivel
FSW-30/24/PA		23-3/8"		

(Above) **Model FS-30/18/PA**  
accessible campfire ring with  
standard flip-over grate.

(Left) **Model FSW-30/18/PA**  
accessible campfire ring with  
optional swivel grate.

These designs have been developed in conjunction with parties interested in providing accessibility in their facilities, and with design guidelines set forth by PLAE, Inc., and the USDA Forest Service in the book "Outdoor Recreation Guidelines" (FSORAG). We have also consulted the guidelines issued by ADAAG. Due to the changing nature of the ADA guidelines, we make no claim that these designs conform in every respect to current/revised ADA criteria. The purchaser must determine suitability for use in a particular facility.

- Web Site: [www.pilotrock.com](http://www.pilotrock.com) •
- E-Mail: [pilotrock@rjthomas.com](mailto:pilotrock@rjthomas.com) •



## Swivel Grate — on Accessible and Standard Firerings

- The Swivel Grate design meets the ADA guidelines for one hand operation and requires less than 5 lbs. of force to move. The 300 sq. in. single level Swivel Grate will move 180 degrees - from over the fire to completely out of the firering - for easy fire building and serving. The handle is never over the fire.
- This Swivel Grate is available on a variety of standard and wheelchair accessible campfire rings. See chart below.
- The cooking grate is a single, welded component using 1/2" dia. steel bars, mounted on a 2-3/8" OD steel tube allowing it to swivel 180 degrees. The operator handle includes a 1/8" x 1/2" flat bar coiled spring grip. All grate bars are welded on both sides. All firerings are finished with high temp non toxic black enamel paint.
- **Optional:** Model S5 bolt on utility shelf is available on most campfire rings. See Page 111.
- **Optional:** Heat Shields are available on some taller firerings. See Page 111.

**Model FSW-30/18/PA** Accessible Campfire Ring, 30" ID x 18" tall (nom.) with ADA compliant 300 sq. in. swivel cooking grate.



(Above) **Model FSW-26/18/PA/H** Accessible Firering, 24" ID, 18" tall (nom.) with ADA compliant 300 sq. in. swivel grate. Shown with optional Heat Shield.  
(Below) Same firering, cooking grate is rotated 180 degrees to the outside position. The handle is never over the fire.



Model	Inside Diameter	Side Ht.	Wheelchair Accessible Height	Heat Shield Available	Anchor Systems	Swivel Cooking Grate Area (Sq. In.)
<b>FSW-26/7/TB</b>	24"	7-3/8"	No	No	TB (Standard), AL, TA (Optional)	300
<b>FSW-30/7/TB</b>	30"	7-3/8"		HS-FSW		
<b>FSW-30/9/TB</b>		9"				
<b>FSW-30/11/TB</b>		11-3/8"				
<b>FSW-48/7/PA</b>	46"	7-3/8"	No	No	PA (Standard) AL Optional	
<b>FSW-48/9/PA</b>		9"				
<b>FSW-48/11/PA</b>		11-3/8"				
<b>FSW-56/7/PA</b>	54"	7-3/8"	No	No	PA (Standard) AL Optional	
<b>FSW-56/9/PA</b>		9"				
<b>FSW-56/11/PA</b>		11-3/8"				
<b>FSW-26/18/PA</b>	24"	16-7/8"	Yes 	HS-F26	TB Only	
<b>FSW-30/18/PA</b>	30"	16-7/8"		HS-FSW		
<b>FSW-30/24/PA</b>		23-3/8"				
<b>FSWDW-30/18/TB</b>	26-3/8"	17-3/8"	No	No	TB Only	

The swivel cooking grate on FSW campfire rings rotates 180 degrees from over the fire to completely outside of the firering. The handle is never over the fire due to it's location and the direction of rotation.

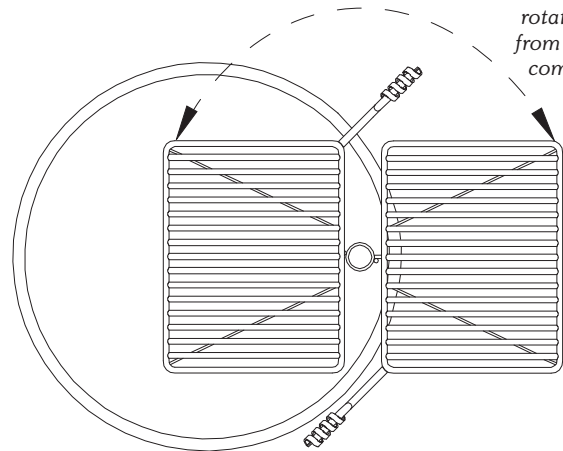

**Model FSW-30/9/TB** Campfire Ring, 30" ID x 9" tall (nom.) with 300 sq. in. swivel cooking grate.

## Multilevel Campfire Ring



Model L-32/6/TB

- **Model L-32** features a 300 sq. inch cooking grate that adjusts to 4 levels, from 2" to 8" above the ring height. Construction includes 3/16" thick steel for the ring and adjustment panels. The 1" formed flange reinforces the ring. The cooking grate is welded together using 5/8" dia. handle/support bars with coiled steel grips, and 1/2" grate bars. All grate bars are welded on both sides. Tip back anchor pins secure the ring in place but allow it to tip up for easy clean up. Finished with high temp non-toxic black enamel paint.
- **Optional:** Bolt on utility shelf Model S5. See Page 111.
- **Optional:** Model RL-35 and RL-36 steel riser platforms for L-32/6 firering. Combined units are wheelchair accessible. Hard surface installation (anchors not included). Use #ANC1-4 anchor kit. See Page 113.

Model	Inside Diameter	Side Ht.	Anchor Systems	Cooking Area (Sq. In.)
L-32/6/TB	30"	6-1/4"	TB (Standard), TA (Optional) See Page 112	300
L-32/9/TB		9"		
L-32/11/TB		11"		

## Large Group Firering



Model O-34/TB

- **Model O-34** is a large ring that offers a choice: build a large campfire in the front section, or build a smaller cooking fire under the grate. Built for large groups, the ring includes a 510 sq. inch single level cooking grate, hinged to tip over the fire or out of the ring. Cooking height is 9". The ring is built from 1/4" thick steel plate reinforced with a 3/16" x 1-1/4" angle iron. The cooking grate assembly includes: 1/4" thick flat steel bar perimeter frame; 1/2" dia. grate bars; 5/8" dia. handle bar with coiled steel bar grips. Tip back anchor pins secure the unit in place.

Model	Inside Dimension	Side Ht.	Anchor Systems	Cooking Area (Sq. In.)
O-34/TB	34 x 40"	6"	TB (Standard), TA (Optional) See Page 112	510

## ADA Guidelines for Campfire Ring



On September 26, 2013 the Final Guidelines for Federal Outdoor Recreation Sites were issued. In the Final Guidelines the reach and operability specifications for campfire rings are as follows:

**1011.5.1 Fire Building Surfaces:** Fire building surfaces shall be 9 inches minimum above the ground.

**1011.5.2 Cooking Surface:** Where provided, cooking surfaces shall be 15 inches minimum and 34 inches maximum above the ground.

**1011.5.3 Raised Edges or Walls:** Where firerings are constructed with raised edges or walls, the depth of the raised edge or wall shall be 10 inches maximum.

**309.4 Operation:** Operable parts shall be operable with one hand and shall not require tight grasping, pinching or twisting of the wrist. The force required to activate operable parts shall be 5 pounds maximum.

R.J. Thomas Mfg. builds a variety of wheelchair accessible and ADA compliant campfire rings. We build our campfire rings to withstand the use and abuse of public campgrounds. On most firerings the cooking grate is designed to be indestructible (two people could stand on it without deformation), but this makes it too heavy for 309.4. Our Model FSW-30/18/PA campfire ring scores highest on all points of accessibility. The swivel grate is lighter weight, meets all the requirements of 309.4, but could suffer damage if abused.

**Our different accessible campfire rings are designed to meet the different requirements of your installations.**

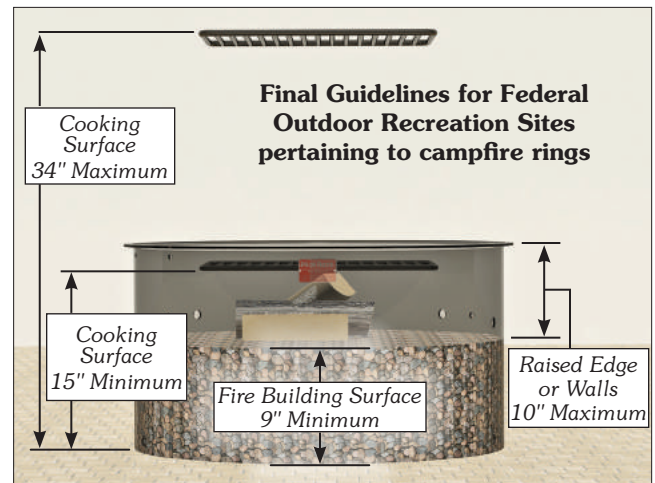

## DIG-U1 Drop-In Grate

### Removable Cooking Grate for Your Firering or Fire Pit

- When you want to grill over your campfire just place **Model DIG-U1** "drop-in" grate across your steel firering or other fire pit. Lift it off when you are done cooking.
- Welded fabrication of 1/2" solid steel grate bars and 1/8" thick steel plate. Finished with high temp non-toxic black enamel paint.
- The handle bars are permanently attached, and lay flat when not in use.
- Cooking area dimensions: 21-1/2" x 15-1/4". 328 sq. inches total.
- Overall dimensions: 36-1/2" long x 15-1/4" wide. Weight: 31 lbs.
- Use Model DIG-U1 with steel rings or stone/concrete fire pits.
- Use this with your backyard firepit and pack it with you when you go picnicking or camping.
- **Model DIG-U1** will fit:  
Round Firerings and Fire Pits: 27" to 31" inside diameter.  
Square Fire Pits: 23" – 27" inside dimension.

*New!*

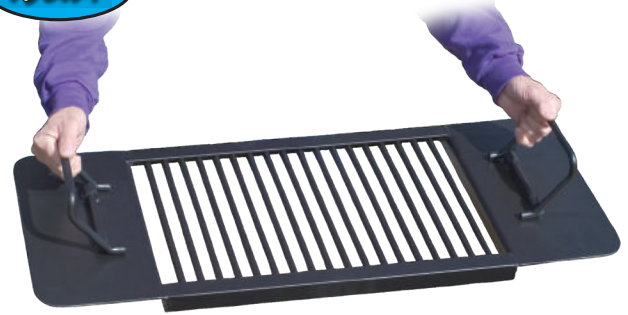

**Model DIG-U1** Drop-in cooking grate.



**Model DIG-U1** Drop-in cooking grate can be used on fire pits constructed of landscaping stones with or without a steel insert.



**Model DIG-U1** Drop-in cooking grate on a Pilot Rock FX-30 Series campfire ring.

## Firering Covers

### Snuffer Covers Can Help You Put Out the Campfire

*New!*

- Can't wait for your campfire to burn itself out? Use a Snuffer Cover to cover the fire and restrict the air supply to the fire. Has it gotten too windy for an open fire? A Snuffer Cover will help to contain and choke your fire out. Just want to protect your campfire ring from the elements when not in use? A Snuffer Cover can help with that, too.
- These firering covers are designed to fit Pilot Rock FA-30, FS-30, FSW-30 and FX-30 Series campfire rings with a 30" ID and 32" OD at the top flange. See chart. They may also fit other brand firerings with similar dimensions.
- **Fabrication:** One piece, 16 ga. pre-galvanized steel, with 1/2" formed lip around outside edge, two handles. A hole is pre-drilled so you can attach a chain or cable kit and secure the cover to the firering (kit is not included).

Snuffer Cover Number	Fits Pilot Rock Campfire Ring Series	Cover Inside Diameter	Cover Weight
<b>CFA-30</b>	FA-30	34-3/4"	17 lbs.
<b>CFS-30</b>	FS-30		
<b>CFSW-30</b>	FSW-30		
<b>CFX-30</b>	FX-30 (no grate)		



**Model CFA-30** Snuffer Cover on a Pilot Rock FA-30 Series campfire ring.



**Model CFS-30** Snuffer Cover on a Pilot Rock FS-30 Series campfire ring.



**Model CFSW-30** Snuffer Cover on a Pilot Rock FSW-30 Series campfire ring.



### Clean Out Shovel for Campfire Rings

- **Model FCS-1** is a specially designed shovel to clean out campfire rings. You can scoop out ashes and coals without disturbing the aggregate or ground surface beneath. The front edge of the shovel is cut to a radius to match the inside curvature of most 30-inch (nom.) inside diameter firerings. The back edge is flat so you can also clean out square corners and flat surfaces found in some firerings. The handle is hinged so you can use either edge of the shovel. It will also come in handy for cleaning out larger 48" and 56" diameter firerings.
- The angle of the shovel and handle make it comfortable to use. The shovel is formed from 14 ga. steel. The 1/2" dia. steel bar handle includes our coiled steel spring grip. Finish: High temp black enamel paint. Some assembly required.

**Model FCS-1** Firering Cleanout Shovel scoops up ashes and coals and debris from inside the ring without disturbing the base surface you want to keep under the campfire.



**Model FCS-1** Firering Cleanout Shovel has one curved edge cut to match the inside radius of most 30" ID campfire rings, plus a straight edge useful for square corners and flat walls found in some ring designs.

### Utility Shelf — Utility Shelf bolts onto both Firerings and Heat Shields



**Model S5** utility shelf provides a handy place for condiments, utensils, or pots and pans. The shelf is available on most firering models and heat shields and will not interfere with grate adjustment. Constructed from 3/16" x 7-1/8" x 9-5/8" plate steel, the shelf is finished in high temperature black enamel paint. Fasteners are included.

Optional Shelf **Model S5** as shown on Model FA-30/18 Firering



Optional Shelf **Model S5** as shown on Model HS-F Heat Shield

### Heat Shields — for Added Protection from Hot Surfaces



- An optional Heat Shield is available on some Pilot Rock firerings (see chart below). This Shield can be added to new or previously installed Pilot Rock firerings to give protection from hot surfaces around the outside of the ring. The 10 ga. x 8" high Shield provides a 1-1/4" air gap around the area of these tall rings exposed to heat (the lower portion of these rings is filled with aggregate). The Shield ring has a 3/8" wide flange formed to the inside. Any debris between the ring and the Shield will fall out the open bottom.
- Installation of the Heat Shield requires no modification of the firering or cooking grate. To order a Heat Shield on a new firering add "/H" at the end of the model number. To order a Heat Shield for an existing firering see the model numbers below.
- **Optional:** Bolt on utility shelf Model S5. See above.

**Note on accessibility:** Current ADA guidelines define the space around campfire rings to provide 48" of clearance. Exceptions can reduce this clearance to 36". In these tighter clearances a Heat Shield could provide an added level of safety.

Model	Outside Diameter	Fits Firering Models
HS-M	33-3/4"	M-32/17/PA
HS-F	33-3/4"	FA-30/11, FA-30/18, FS-30/18/PA, FS-30/24/PA, FS-30/11
HS-F26	27-3/4"	FSW-26/18/PA
HS-FSW	9", 11", 18" and 24" tall	FX and FSW

**Model HS-M** Heat Shield on Model M-32/17 Firering with optional utility shelf.

U.S. PATENT NO. 6,553,984

## Firering Anchoring Systems

Firerings may be anchored in several different ways. Not all anchoring systems are available on all firerings. Check the description for each firering to determine which anchoring options are available.



### TIP-BACK ANCHORS (TB)

Tip-back anchors for firerings, as specified by /TB in the model numbers, permanently locate firerings yet allow them to tip back for easy clean-out.

The anchors are 1/2" dia. steel rod designed to be installed through welded-on tip-back brackets at the rear of the firering and embedded 15" into a concrete footing.



### TIP-BACK ANGLE SPADE ANCHORS (TA)

Tip-back angle spade anchors for firerings, as specified by /TA in the model numbers, secure firerings on site without concrete footings and allow the firering to tip back.

Two angle spade anchors are inserted into the ground. The 1/2" dia. steel rod hinge pin is inserted through holes in each anchor and through the holes in the tip-back brackets welded to the firering. The rod is bent to secure the firering to the anchors.



### ANGLE SPADE ANCHORS (AL)

Angle spade anchors for firerings, as specified by /AL in the model numbers, secure firerings on site. The firering cannot be tipped up.

The anchors are constructed of heavy 3/16" x 1-3/4" x 1-3/4" A-36 steel angle with a welded-on spade of 1/8" steel. Anchors are attached at equidistant points around the firering and installed directly into the ground without the need for concrete.



### PIN ANCHORS (PA)

Pin anchors for firerings, as specified by /PA in the model numbers, permanently locate firerings.

The anchors are "U" shaped 1/2" dia. steel rods and are embedded 15" into concrete footings. The anchors are installed through the draft/drain holes located around the lower perimeter of each firering. The firering cannot be tipped up.

## Anchor Kits



### Strap Anchor:

One pair, secure tables with steel tube frames. 1/4" dia. holes. Anchor bolts not included.

**Model ANG-3:** fits 2-3/8" OD frames – XT, XTH, WXT, WXTH, and BTXG tables.

**Model ANG-5:** fits 1-5/8" OD frames – UT, UTH, UTK, WUT, WUTH, BTUG, and SQT tables.

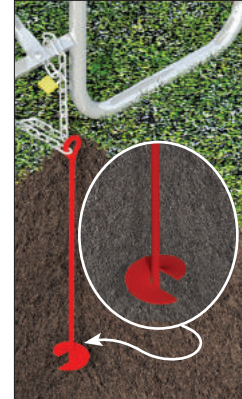

### Auger Anchor:

Screw-type auger; 1/2" diameter steel shaft with 3-1/2" dia. auger. Screw into ground until only "eye" is exposed. Includes 30" long heavy link chain secured to stake with cold shut. Optional **Model PL-1** padlock can secure chain to table. **Model AGS-1.**



### Angle Anchor:

One pair of formed steel angles. Use with AT, AFT, and RT tables and RB benches. Angles attach to frames with included screws. Then secure to surface with 3/8" dia. bolts appropriate for mounting surface (not included). Use one pair per frame. **Model ANG-2.**

### Drive-in Ground Anchor:

Driven deep into ground with heavy hammer and optional drive stake. Attaches to table or bench with wire rope and/or heavy chain.

Optional **Model PL-1** padlock secures wire rope to bench/table.

**Model 68-AT1:** 1100 lb. capacity, 3/16" x 5 ft. galvanized wire rope.

**Model 88-AT1:** 3000 lb. capacity, 1/4" x 6 ft. galvanized wire rope.

**Model 68-ATC:** 1100 lb. capacity, 1/4" x 4 ft. proof coil chain with 1 ft. wire rope.

**Model 88-ATC:** 3000 lb. capacity, 1/4" x 4 ft. proof coil chain with 2 ft. wire rope.

### Drive Rods:

**Model DS-68:** 1/2" x 3 ft. steel rod with large striking head. Use with #68-AT1 and #68-ATC anchors.

**Model DS-1:** 3/4" x 4 ft. steel rod tapered to 1/2", heavy-duty frequent use. Use with #68-AT1 and #68-ATC.

**Model DS-2:** 3/4" x 4 ft. steel rod. For use with #88-AT1 and #88-ATC.





ANCHOR KITS	PRODUCTS					
	BENCHES	BIKE RACKS & PARKING	TABLES	WASTE & RECYCLING	AMENITIES	GRILLS & FIRERINGS
BR-4HSA (4) 3/8" x 1-7/8" Bolt Sleeve	CLB, GB-4, GB-6, GB3, GB4 (2 Kits per Bench)	BR-6DS, BR-6SS, BR-12DS, BS, BSM		SS/P-1 <sup>‡5</sup>		HCB-1
ANC1-4 (4) 1/2" x 3" Screw Anchors (See ‡1)	APB/P (1 Kit per leg), B30, B32, OWB/P, OWRB/P, PWB, PWRB	BR20, BR30, BR31 BR102, BR104, BR106	APT/P (1 Kit per leg)	M3, M5, M7, M11, CN-TR/P-52 <sup>‡5</sup>	TB-1, APTX/P, ULT/P-1, ULT/P-2, ULT/P-4 ULT/P-3 (2 Kits per Table)	B3, B7, B8, B17, B18, RL-35, RL-36
ANC1-6 (6) 1/2" x 3" Screw Anchors (See ‡1)	B30C, B32C, PWB3, PWRB3					
ANC2-4 (4) 3/8" x 5" Screw Anchors (See ‡1)	6' & 8' B302; 21' B304 (2 Kits per 21' Bench)	BR205SS, BR210SS, BR210DS, HRP-6		CN-R/SS2-36D, CN-Q/SS4-36D		
ANC2-6 (6) 3/8" x 5" Screw Anchors (See ‡1)	12' & 15' B303	BR220DS, HRP-8				
ANC3-4 (4) 3/8" x 3" Screw Anchors (See ‡1)	PAB, SAB/P, PCB, PCXB, B40, B42, B60, B62, B76, B78, B80, B82, B100, B102, B120, B122, B130, B132, 4', 5', 6' BC3000, BC4000, B400, B410, B412	HRP, SRP-3, SRP-5, SRP-7, SRP-9, SRP-11, BR310DS	6' & 8' T600, 6' & 8' T700, TQ700, 6' & 8' T702 (need three kits), TQ704 (need five kits)	CN-OKR-36 <sup>‡5</sup> , CN-R/SS2-36, CN-R/SP2-32, CN-R/SS3-36, CN-AMR, CN-AMQ, CN-R/R, CN-R/D, CN-Q/D-32, CN-Q-36, CN-AMR-ASH, CN-AMQ-ASH, CN-R/SS3-ASH	6' & 8' XTX, P-22, P-23, P-30	GS-5
ANC3-6 (6) 3/8" x 3" Screw Anchors (See ‡1)	PAB3, SAB3/P, PCB3, PCXB3, B40C, B42C, B110, 8' BC3002, 8' BC4002	ORP, SRP-13, BR320DS	10' T600		10' XTX	
ANC4-4 (4) 1/2" x 3-3/4" Wedge Anchors (See ‡1)	B90, B92					
ANC5-4 (4) 1/2" x 5" Screw Anchors (See ‡1)			PT/P, PQT/P, TPT/P, T400	CN-VDT/P-32 <sup>‡5</sup> , BPR1-36 <sup>‡5</sup>	TB-2 BPFL <sup>‡5</sup>	
ANC5-6 (6) 1/2" x 5" Screw Anchors (See ‡1)				BPR2-72 <sup>‡5</sup> , BPR3-108 <sup>‡5</sup>		
ANC6-4 (4) 1/4" x 1-3/4" Screw Anchors (See ‡1)	Used with all ANG-3 and ANG-5 Strap Anchors on Page 112					
ANC10-3 (3) 3/4" x 17-3/4" Anchor Stakes (See ‡2)		CSL-6, CSL-8	<b>‡ NOTES:</b> <b>1. All BR-4HSA, ANC1, ANC2, ANC3, ANC4, ANC5, and ANC6 Anchor Kits</b> are for concrete surface installations only. <b>2. ANC10, ANC11, and ANC12 Anchor Kits</b> are for asphalt or ground surface installations only. <b>3. Model BB Bike Block</b> includes (2) 3/8" x 3" screw anchors for each block. <b>4. Models Q3-2460, P-1000, and L-1500 Grills</b> include (4) 1/2" x 6" J-bolts for embedding into concrete footings. (Install when concrete is poured.) <b>5. Model SS/P-1, Models CN-TR/P-52, CN-OKR-36</b> trash receptacles, and <b>Model CN-VDT/P-32</b> trash can cover, and all <b>Model BPR</b> bear resistant receptacles and <b>Model BPFL</b> bear resistant food lockers each include a set of anchor bolts. Order replacement anchor kits above.			
ANC11-3 (3) 3/4" x 17-3/4" Anchor Stakes (See ‡2)		SB-6, SB-8				
ANC12-3 (3) 3/4" x 24" Anchor Stakes (See ‡2)		CSL-6, CSL-8				

# WARRANTY & ORDERING INFORMATION

## PRODUCT WARRANTY

TERM	PRODUCT	OTHER INFORMATION	REQUIREMENTS	EXCLUSIONS
<b>LIFETIME</b>	Picnic Table Frames: UT, UTH, XT, XTH, WUT, WUTH, WXT, WXTH	Original Owner Only	All products must: 1) be assembled and installed according to manufacturer's specifications and instructions. 2) be properly maintained 3) not have been altered by the addition or deletion of parts, or modified in any other manner.	Vandalism. Damage caused by incorrect assembly, installation, application (use), or negligence. Natural or manmade disasters. Cosmetic changes due to weathering - including paint fading, discoloration of wood, or color fading or spotting of coated steel and recycled plastic products caused by exposure to natural elements or chemicals. Scratches, dents, or marring caused by normal use and public exposure. Seasons checks, twisting, or splintering of wood caused by climatic differences or lack of proper maintenance. Loss or damage in transit while product is responsibility of carrier. High heat paint subject to overly built fires. Steel warpage caused by fires of excessive size or duration Premature rust-through of grill boxes due to improper cleaning or maintenance. Premature rusting or discoloring caused by corrosive environment or while in ocean transit. Damage caused by animals or wildlife.
<b>ONE YEAR</b>	Powder Coat, Enamel, & High Heat Paints; Lumber; Trash & Recycling Lids & Liners; Plaques; Decals; Resin Fill; Umbrellas; Pet Waste Stations; FSW Swivel Grate	No Warranty on Lumber shipped outside the United States. Water Repellant recommended on Lumber.		
<b>FOUR YEARS</b>	Thermo-Plastic Coating	Limited and Prorated Warranty on coating material against defects when subjected to normal use and proper maintenance.		
<b>FIVE YEARS</b>	Picnic Table Frames (those not included in Lifetime Warranty), Park Bench Frames, Steel and Aluminum Bench and Table seat/top Structures, Recycled Plastic Components, Bike Racks, TRH and TRQ Frames, Steel Trash Receptacle and Planter Structures, Pedestal Mounts, Tissue Holders, all Grills, Hot Coal Bin, Utility Tables, Steel Campfire Rings, Lantern Holders, Table Mover	Recycled Plastic warranty applies only to components that have been cut, drilled, or routed by the manufacturer. This warranty does NOT cover plastic purchased in raw stock form by customer and cut, drilled, or routed by customer for custom application. Recycled Plastic and Thermo-Plastic coated components include a UV stabilizer to retard effects of natural exposure. We cannot warrant "fading" or surface "contamination" due to extreme variations in levels of exposure and in the definition of "fading".		
<b>FIFTY YEARS</b>	Recycled Plastic	Material decomposition only.		
Warranty claims must be filed within the warranty period and must include a copy of the invoice or the purchase order.				
Except as specifically stated herein, all warranties (expressed or implied) are hereby excluded. This Warranty excludes any liability, consequential damages, or related costs.				

## ORDERING INFORMATION

Write Purchase Orders and Payments to: R. J. Thomas Mfg. Co., Inc. R. J. Thomas Mfg. Co., Inc. is a small business.

GSA Contracts are available for federal accounts. Contact Customer Service for Contract information.

**PRICE:** All prices are F.O.B. Cherokee, Iowa. Prices subject to change without notice. Quantity discounts and freight allowance available.

**TERMS:** Net due 30 days from date of invoice to those with established credit. First time orders and others: prepayment in full before shipment. Finance charges after 30 days. Payment by credit card is accepted using:



**FREIGHT:** Prepaid and added to the invoice, or third-party billed. Weights listed are approximate and do not include packaging. Shipment will be made by the quickest, most economical and practical means possible. Call for freight estimate. Most products are shipped unassembled to minimize shipping costs. Detailed assembly instructions are included with fasteners.

**LEAD TIMES:** We encourage you to order as early as possible. Our usual lead times run four weeks. Busy season lead times can reach to six to eight weeks. When you order early we can better arrange delivery to meet your needs.

**SPECIFICATIONS:** Specifications were in effect when printing this catalog. Since product improvements are always being made, we reserve the right to change designs, specifications and discontinue products without notice. Where changes have been made, revised products will be shipped unless specific arrangements have been made to the contrary.

**ADDITIONAL INFORMATION:** Contact us if you require additional information on product specifications, assembly, or installation. Spec Bulletins are available on our web site.

**MODIFICATIONS:** If a desired combination of features, materials, options, or accessories is not covered in this catalog, contact us and we will advise as to availability and price.

**RETURN POLICY:** No returns are accepted without prior approval. Call Customer Service for a Return Authorization (RA) number. Requests must be made within thirty days of receipt of product. No returns will be accepted after thirty days. Products must be returned in original packaging, must not be used or damaged, and must be in resalable condition. Returns may be subject to a restocking charge. Return freight must be prepaid.

**ORDER CANCELLATION:** Orders may be cancelled prior to shipment. Conditions will vary. Orders with custom plaques/engraving, etc. cannot be cancelled once we receive final design approval. Orders cancelled after shipment are subject to return freight charges and restocking fees.

# ENJOY THE OUTDOORS ... WHERE EVER YOU FIND IT

Parks  
 Schools  
 Rec Centers  
 Streetscapes  
 Housing Associations  
 Campgrounds  
 Aquatic Parks  
 Churches

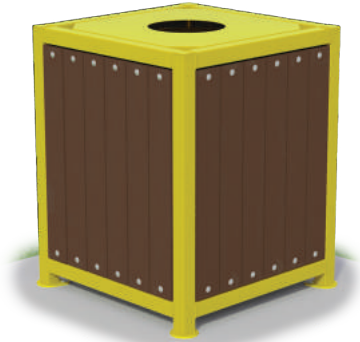

No matter where you go to Enjoy the Outdoors, Pilot Rock has site amenities to make your experience more enjoyable. Benches ... Picnic Tables ... Trash and Recycling Containers ... Bike Racks ... Charcoal Grills ... Campfire Rings ... and more ... all designed to enhance your experience, and built to withstand constant exposure to the public and the elements.

Across the different product lines our products can be coordinated by selecting matching materials and colors to achieve the look you want. By using select materials you can match a park bench to a picnic table to a trash receptacle to a planter. Product styles and colors are available for any landscape.

The visible impact on your public will be enhanced with product coordination ... and custom identification. Custom engraving and plaques are available on many products. Plus we offer custom banners and signs to help promote your facility and programs.

Enjoy the Outdoors!

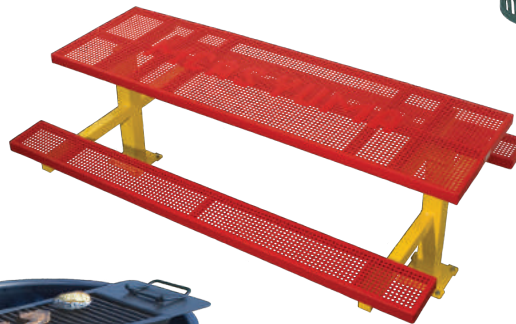

Businesses  
 Kids' Camps  
 RV Parks  
 Memorials  
 Athletic Fields  
 Service Projects  
 Tailgating Areas  
 Swimming Pools



# Enjoy the Outdoors™

with...

**Benches**

**Picnic Tables**

**Trash & Recycling  
Containers**

**Bike Racks**

**Lantern Poles**

**Utility Tables**

**Planters**

**Charcoal Grills**

**Campfire Rings**

**& More**

**Made in the USA**

## Pilot Rock®

*Serving the business of recreation with*

**PARK · STREET · CAMP  
SITE PRODUCTS**

Designed and Manufactured by

**RJThomas Mfg. Co., Inc.**

Mailing: PO Box 946  
Cherokee, IA 51012-0946

Physical: 5648 Hwy 59 South  
Cherokee, IA 51012

Phone: 712-225-5115 · 800-762-5002

Fax: 712-225-5796

E-Mail: [pilotrock@rjthomas.com](mailto:pilotrock@rjthomas.com)

Web Site: [www.pilotrock.com](http://www.pilotrock.com)

© 2014 RJThomas Mfg. Co. maintains all copyrights to information, images, and photos used in this catalog. Printed in USA  
PILOT ROCK is a registered trademark of RJThomas Mfg. Co., Inc.

